

HAMMER DRILL TIPS – ANSI

46600..

Hammer drill tips – ANSI
 Hammerbohrerplatten – ANSI
 Plaquettes pour mèche marteau – ANSI
 Placchette per punte a percussione – ANSI
 Puntas de brocas para percusion – ANSI

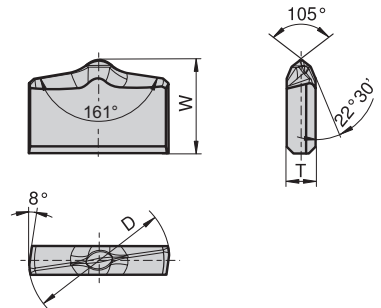

Type, description	Ø [inch]	D [mm]	Tol. [mm]	W [mm]	Tol. [mm]	T [mm]	Tol. [mm]
46600..	1/8"	3.485	±0.075	4.00	±0.10	0.950	±0.050
	5/32"	4.265	±0.075	4.15	±0.10	0.950	±0.050
	11/64"	4.675	±0.075	4.65	±0.10	1.150	±0.050
	3/16"	5.130	±0.10	4.65	±0.10	1.150	±0.050
	13/64"	5.510	±0.10	5.25	±0.10	1.150	±0.050
	7/32"	5.920	±0.10	5.30	±0.10	1.350	±0.050
	15/64"	6.300	±0.10	5.30	±0.10	1.550	±0.050
	1/4"	6.710	±0.10	5.30	±0.10	1.550	±0.050
	17/64"	7.110	±0.10	6.15	±0.10	1.550	±0.050
	9/32"	7.620	±0.10	6.15	±0.10	1.550	±0.050
	5/16"	8.410	±0.10	6.45	±0.10	1.950	±0.050
	3/8"	10.010	±0.10	6.85	±0.10	2.125	±0.075
	7/16"	11.765	±0.125	7.70	±0.10	2.125	±0.075
	1/2"	13.335	±0.125	8.70	±0.10	2.725	±0.075
	9/16"	14.915	±0.125	9.10	±0.10	2.925	±0.075
	5/8"	16.635	±0.125	9.40	±0.10	2.925	±0.075
	11/16"	18.235	±0.125	9.65	±0.10	3.400	±0.100
	3/4"	19.840	±0.150	11.55	±0.10	3.400	±0.100
	13/16"	21.410	±0.150	11.55	±0.10	3.400	±0.100
	27/32"	22.230	±0.150	12.15	±0.10	3.900	±0.100
	7/8"	23.140	±0.150	12.15	±0.10	3.900	±0.100
	15/16"	24.740	±0.150	13.25	±0.10	4.400	±0.100
	1"	26.320	±0.150	13.25	±0.10	4.400	±0.100
	1 1/16"	28.080	±0.190	14.70	±0.10	4.900	±0.100
	1 1/8"	29.660	±0.190	14.70	±0.10	4.900	±0.100
	1 1/4"	32.830	±0.190	16.80	±0.10	5.400	±0.100
	1 5/16"	34.530	±0.190	16.80	±0.10	5.400	±0.100
	1 3/8"	36.010	±0.190	16.80	±0.10	5.400	±0.100
	1 7/16"	37.580	±0.190	17.35	±0.10	5.900	±0.100
	1 1/2"	39.180	±0.190	17.35	±0.10	5.900	±0.100
	1 9/16"	40.585	±0.255	19.75	±0.10	6.400	±0.100
	1 3/4"	45.265	±0.255	20.75	±0.10	6.900	±0.100
2"	51.815	±0.255	23.50	±0.25	6.900	±0.100	