

Hammer drill tips – ANSI
 Hammerbohrerplatten – ANSI
 Plaquettes pour mèche marteau – ANSI
 Placchette per punte a percussione – ANSI
 Puntas de brocas para percusion – ANSI

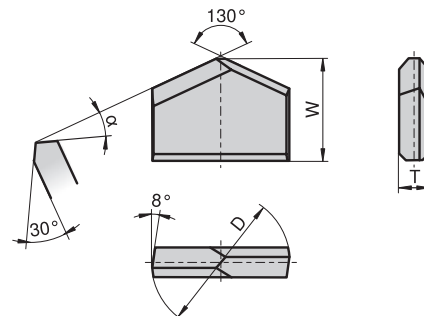

Type, description	Ø [inch]	ANSI code	D		W		T		α
			[mm]	Tol. [mm]	[mm]	Tol. [mm]	[mm]	Tol. [mm]	
17871..	1/8"	HDG 2	3.55	-0.15	4.16	+0.25	0.9	-0.10	20°
	5/32"	HDG 2.5	4.34	-0.15	4.50	+0.20	1.0	-0.10	20°
	11/64"	HDG 2.75	4.75	-0.15	5.00	+0.20	1.2	-0.10	20°
	3/16"	HDG 3	5.23	-0.20	5.00	+0.20	1.2	-0.10	20°
	13/64"	HDG 3.25	5.61	-0.20	5.60	+0.20	1.2	-0.10	20°
	7/32"	HDG 3.5	6.02	-0.20	5.60	+0.20	1.4	-0.10	20°
	15/64"	HDG 3.75	6.40	-0.20	5.60	+0.20	1.4	-0.10	20°
	1/4"	HDG 4	6.81	-0.20	5.60	+0.20	1.4	-0.10	20°
	17/64"	HDG 4.24	7.31	-0.20	6.60	+0.10	1.6	-0.10	20°
	9/32"	HDG 4.5	7.72	-0.20	6.60	+0.20	1.6	-0.10	20°
	5/16"	HDG 5	8.51	-0.20	6.60	+0.20	2.0	-0.10	20°
	3/8"	HDG 6	10.11	-0.20	7.50	+0.20	2.2	-0.15	20°
	7/16"	HDG 7	11.89	-0.25	8.50	+0.20	2.2	-0.15	20°
	1/2"	HDG 8	13.46	-0.25	9.50	+0.20	2.8	-0.15	30°
	9/16"	HDG 9	15.04	-0.25	9.50	+0.20	3.0	-0.15	30°
	5/8"	HDG 10	16.76	-0.25	10.50	+0.20	3.0	-0.15	30°
	11/16"	HDG 11	18.36	-0.25	11.00	+0.20	3.5	-0.20	30°
	3/4"	HDG 12	19.99	-0.30	13.00	+0.20	3.5	-0.20	30°
	13/16"	HDG 13	21.50	-0.30	13.00	+0.20	3.5	-0.20	30°
	27/32"	HDG 13.5	22.38	-0.30	14.00	+0.20	4.0	-0.20	30°
	7/8"	HDG 14	23.29	-0.30	14.00	+0.20	4.0	-0.20	30°
	15/16"	HDG 15	24.89	-0.30	15.00	+0.20	4.5	-0.20	30°
	1"	HDG 16	26.47	-0.30	15.00	+0.20	4.5	-0.20	30°
	1 1/8"	HDG 18	29.85	-0.38	17.00	+0.20	5.0	-0.20	30°
1 1/4"	HDG 20	33.02	-0.38	19.00	+0.20	5.5	-0.20	30°	
1 3/8"	HDG 22	36.20	-0.38	19.00	+0.20	5.5	-0.20	30°	
1 1/2"	HDG 24	39.37	-0.38	21.00	+0.20	6.0	-0.20	30°	
2"	-	-	52.07	-0.51	26.00	+0.50	7.0	-0.20	30°