

HAMMER DRILL TIPS – JAPAN

26000..

Hammer drill tips – JAPAN
Hammerbohrerplatten – JAPAN
Plaquettes pour mèche marteau – JAPAN
Placchette per punte a percussione – JAPAN
Puntas de brocas para percusion – JAPAN

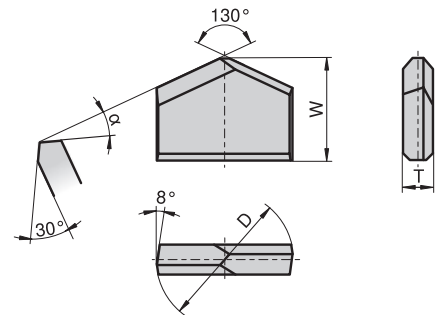

Type, description	Ø [mm]	D [mm]	Tol. [mm]	W		T		α
				[mm]	[mm]	[mm]	[mm]	
26000..	4.0	4.0	+0.20	4.2	+0.20	1.0	-0.10	20°
	4.3	4.3	+0.20	4.5	+0.20	1.0	-0.10	20°
	4.8	4.8	+0.20	4.8	+0.20	1.0	-0.10	20°
	5.0	5.0	+0.20	5.0	+0.20	1.2	-0.10	20°
	6.0	6.0	+0.20	5.3	+0.20	1.4	-0.10	20°
	6.4	6.4	+0.25	5.6	+0.20	1.4	-0.10	20°
	7.0	7.0	+0.25	5.8	+0.20	1.6	-0.10	20°
	8.0	8.0	+0.25	6.5	+0.30	2.0	-0.10	20°
	9.0	9.0	+0.25	6.9	+0.30	2.0	-0.15	20°
	9.5	9.5	+0.25	6.9	+0.30	2.0	-0.15	20°
	10.0	10.0	+0.25	7.5	+0.30	2.2	-0.15	20°
	10.5	10.5	+0.30	8.0	+0.30	2.2	-0.15	20°
	11.0	11.0	+0.30	8.5	+0.30	2.2	-0.15	20°
	12.0	12.0	+0.30	9.0	+0.30	2.5	-0.15	20°
	12.5	12.5	+0.30	9.0	+0.30	2.5	-0.15	20°
	12.7	12.7	+0.30	9.0	+0.30	2.5	-0.15	20°
	13.5	13.5	+0.30	9.5	+0.30	2.8	-0.15	30°
	14.5	14.5	+0.30	9.8	+0.30	3.0	-0.15	30°
	15.0	15.0	+0.30	10.5	+0.50	3.0	-0.15	30°
	16.0	16.0	+0.30	10.5	+0.50	3.0	-0.15	30°
	16.5	16.5	+0.30	10.5	+0.50	3.0	-0.15	30°
	17.0	17.0	+0.30	10.5	+0.50	3.0	-0.15	30°
17.5	17.5	+0.30	10.5	+0.50	3.0	-0.15	30°	
18.0	18.0	+0.35	11.0	+0.50	3.5	-0.20	30°	
19.0	19.0	+0.35	12.0	+0.50	3.5	-0.20	30°	
20.0	20.0	+0.35	13.0	+0.50	3.5	-0.20	30°	
22.0	22.0	+0.35	14.0	+0.50	4.0	-0.20	30°	