

MASONRY DRILL TIPS – ANSI

22000..

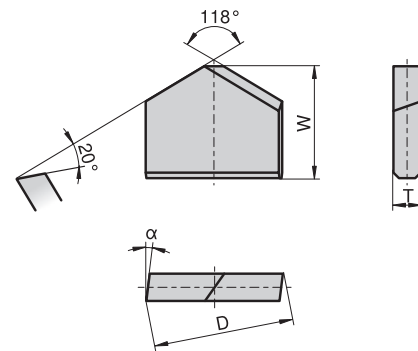

Masonry drill tips – ANSI
Schlagbohrerplatten – ANSI
Plaquettes pour mèche maçonnerie – ANSI
Placchette per punte a forare – ANSI
Puntas de brocas para hormigon – ANSI

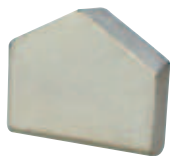

Type, description	Ø [inch]	ANSI code	D [inch]	Tol. [inch]	W [inch]	Tol. [inch]	T [inch]	Tol. [inch]	α
22000..	1/8"	MDG 2	0.140	-0.006	0.164	+0.010	0.035	-0.003	9°
	5/32"	MDG 2.5	0.171	-0.006	0.180	+0.010	0.035	-0.003	9°
	3/16"	MDG 3	0.206	-0.008	0.197	+0.010	0.045	-0.003	8°
	7/32"	MDG 3.5	0.237	-0.008	0.220	+0.010	0.045	-0.003	8°
	1/4"	MDG 4	0.268	-0.008	0.220	+0.010	0.060	-0.003	8°
	9/32"	MDG 4.5	0.304	-0.008	0.260	+0.010	0.060	-0.003	7°
	5/16"	MDG 5	0.335	-0.008	0.260	+0.010	0.060	-0.003	7°
	3/8"	MDG 6	0.398	-0.008	0.320	+0.010	0.078	-0.003	7°
	7/16"	MDG 7	0.468	-0.010	0.375	+0.015	0.078	-0.003	7°
	1/2"	MDG 8	0.530	-0.010	0.430	+0.015	0.091	-0.004	7°
	9/16"	MDG 9	0.592	-0.010	0.472	+0.015	0.091	-0.004	7°
	5/8"	MDG 10	0.660	-0.010	0.510	+0.015	0.091	-0.004	7°
	3/4"	MDG 12	0.787	-0.012	0.598	+0.015	0.091	-0.004	7°
	7/8"	MDG 14	0.917	-0.012	0.650	+0.015	0.091	-0.004	7°
	1"	MDG 16	1.042	-0.012	0.718	+0.015	0.122	-0.005	7°
	1 1/8"	MDG 18	1.175	-0.018	0.758	+0.020	0.122	-0.008	7°
	1 1/4"	MDG 20	1.300	-0.018	0.758	+0.020	0.122	-0.008	7°
1 3/8"	MDG 22	1.425	-0.018	0.843	+0.020	0.122	-0.008	7°	
1 1/2"	MDG 24	1.550	-0.018	0.843	+0.020	0.122	-0.008	7°	

ANSI 22000..

MASONRY DRILL TIPS

Codification code example: 22000- 1/8" CTF12-BC