

Masonry drill tips – ANSI
 Schlagbohrerplatten – ANSI
 Plaquettes pour mèche maçonnerie – ANSI
 Placchette per punte a forare – ANSI
 Puntas de brocas para hormigon – ANSI

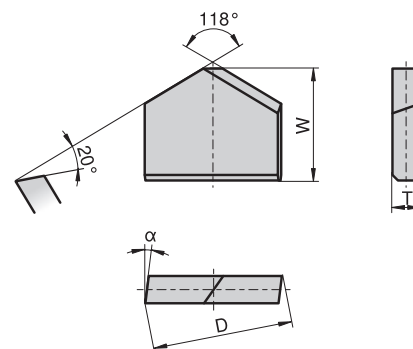

Type, description	Ø [inch]	ANSI code	D		W		T		α
			[mm]	Tol. [mm]	[mm]	Tol. [mm]	[mm]	Tol. [mm]	
22000..	1/8"	MDG 2	3.55	-0.15	4.16	+0.25	0.89	-0.07	9°
	5/32"	MDG 2.5	4.34	-0.15	4.57	+0.25	0.89	-0.07	9°
	3/16"	MDG 3	5.23	-0.20	5.00	+0.25	1.15	-0.07	8°
	7/32"	MDG 3.5	6.01	-0.20	5.58	+0.25	1.15	-0.07	8°
	1/4"	MDG 4	6.80	-0.20	5.58	+0.25	1.52	-0.07	8°
	9/32"	MDG 4.5	7.72	-0.20	6.60	+0.25	1.52	-0.07	7°
	5/16"	MDG 5	8.50	-0.20	6.60	+0.25	1.52	-0.07	7°
	3/8"	MDG 6	10.10	-0.20	8.12	+0.25	1.98	-0.07	7°
	7/16"	MDG 7	11.88	-0.25	9.52	+0.38	1.98	-0.07	7°
	1/2"	MDG 8	13.46	-0.25	10.92	+0.38	2.31	-0.10	7°
	9/16"	MDG 9	15.03	-0.25	11.98	+0.38	2.31	-0.10	7°
	5/8"	MDG 10	16.76	-0.25	12.95	+0.38	2.31	-0.10	7°
	3/4"	MDG 12	19.98	-0.30	15.18	+0.38	2.31	-0.10	7°
	7/8"	MDG 14	23.29	-0.30	16.51	+0.38	2.31	-0.10	7°
	1"	MDG 16	26.46	-0.30	18.23	+0.38	3.09	-0.12	7°
	1 1/8"	MDG 18	29.84	-0.45	19.25	+0.50	3.09	-0.20	7°
1 1/4"	MDG 20	33.02	-0.45	19.25	+0.50	3.09	-0.20	7°	
1 3/8"	MDG 22	36.19	-0.45	21.41	+0.50	3.09	-0.20	7°	
1 1/2"	MDG 24	39.37	-0.45	21.41	+0.50	3.09	-0.20	7°	

Codification code example: 22000-1/8" CTF12-BC