

Стружколомы для негативных пластин



-TMF

- Чистовая, получистовая обработка
- Мягкие стали, материалы со сливной стружкой
- Хороший отвод стружки
- Копировальное точение

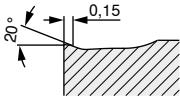
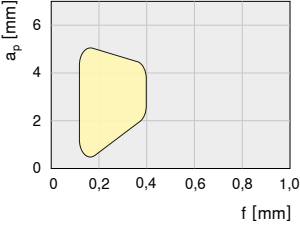

CNMG 120408..

Условия резания		
		
СТСР115	СТСР125	СТСР135
СТСР125	СТСР135	СТСР135
	СТСК120	
СТСР135		



-TM

- Получистовая обработка
- Универсальный стружколом

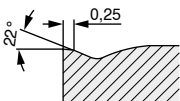
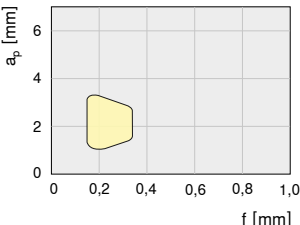

CNMG 120408..

Условия резания		
		
СТСР115	СТСР125	СТСР135
СТСР125	СТСР135	СТС2135
	СТСК120	
СТС2135	СТС2135	



-M50

- Получистовая обработка
- 1-й выбор для обработки стали
- Универсальное применение

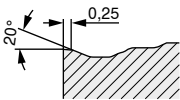
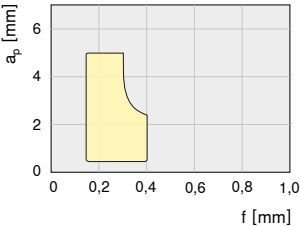

CNMG 120408..

Условия резания		
		
СТСР115	СТСР125	СТСР135
СТСР115	СТСР135	СТСР135
	СТСР125	СТСР125



-M60

- Получистовая, получерновая обработка
- Стабильная режущая кромка
- Прерывистое резание
- Обработка по корке

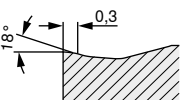
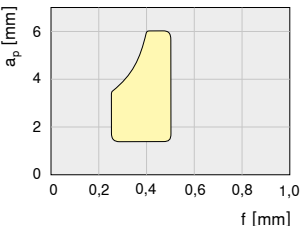

CNMG 120408..

Условия резания		
		
СТРМ125	СТРМ125	СТРМ125
СТРМ125	СТРМ125	СТРМ125
	СТРМ125	СТРМ125