

# DIN 69871

Shell mill adapters for MT shanks / Morse taper adapters with tang

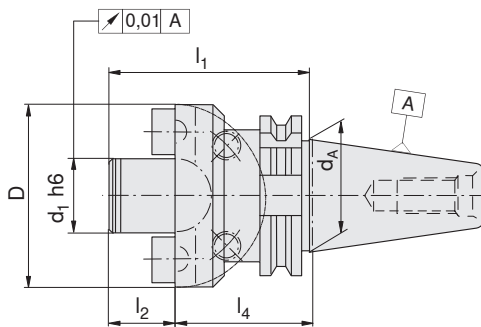

Type, description	d <sub>1</sub> [mm]	d <sub>A</sub> [mm]	D [mm]	l <sub>1</sub> [mm]	l <sub>2</sub> [mm]	l <sub>4</sub> [mm]	
69871-A40-MA40-60	40	40	89	90	30	60	E01
69871-A50-MA40-70	40	50	89	100	30	70	E01
69871-A50-MA60-70	60	50	129	110	40	70	E02

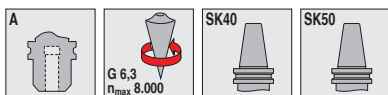
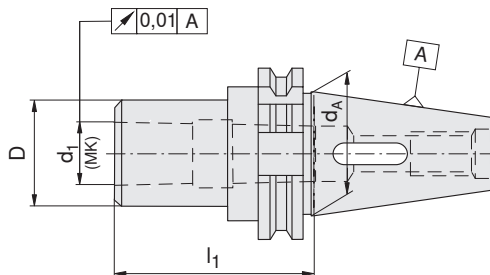
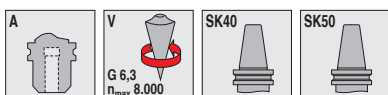

Type, description	d <sub>1</sub> Morse taper [MK]	l <sub>1</sub> [mm]	d <sub>A</sub> [mm]	D [mm]
69871-A40-MK1D-50-V	1	50	40	25
69871-A40-MK2D-50-V	2	50	40	32
69871-A40-MK3D-70-V	3	70	40	40
69871-A40-MK4D-95-V	4	95	40	48
69871-A50-MK1D-50-V	1	50	50	25
69871-A50-MK2D-60-V	2	60	50	32
69871-A50-MK3D-65-V	3	65	50	40
69871-A50-MK4D-95-V	4	95	50	48
69871-A50-MK5D-105-V	5	105	50	63

E01	8395029500	8395013800	8395014000
E02	8395029800		333940 / 8395016000

