

Drilling, turning, parting and grooving with only one tool

- The ProfileMaster is excellently suited for profiles that are so complex that they can normally only be produced with the use of several tools
- In addition, it helps free up valuable positions on the machine and minimise the need to change tools
- Thanks to the Masterfinish effect, the ProfileMaster produces an excellent surface finish in the shortest possible time

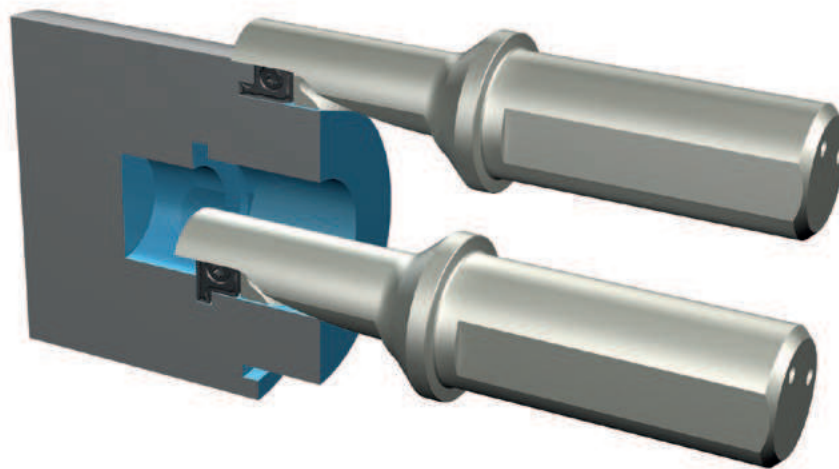

Material groups

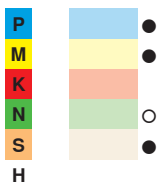

Possible applications

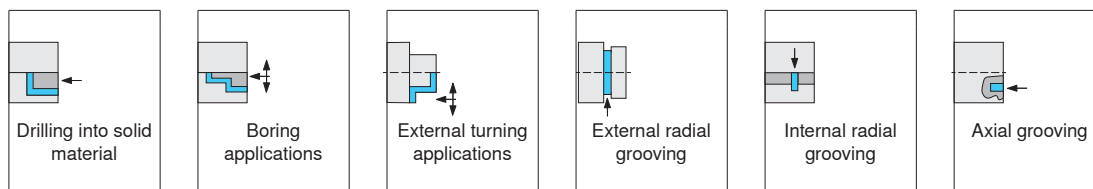

Detailed information

Diameter / length ratio	Ø range	Inserts
1,5 x D 2,25 x D	Ø 10 - 32 mm	PM 10.. .. PM 32..