

ProfileMaster

Machining methods

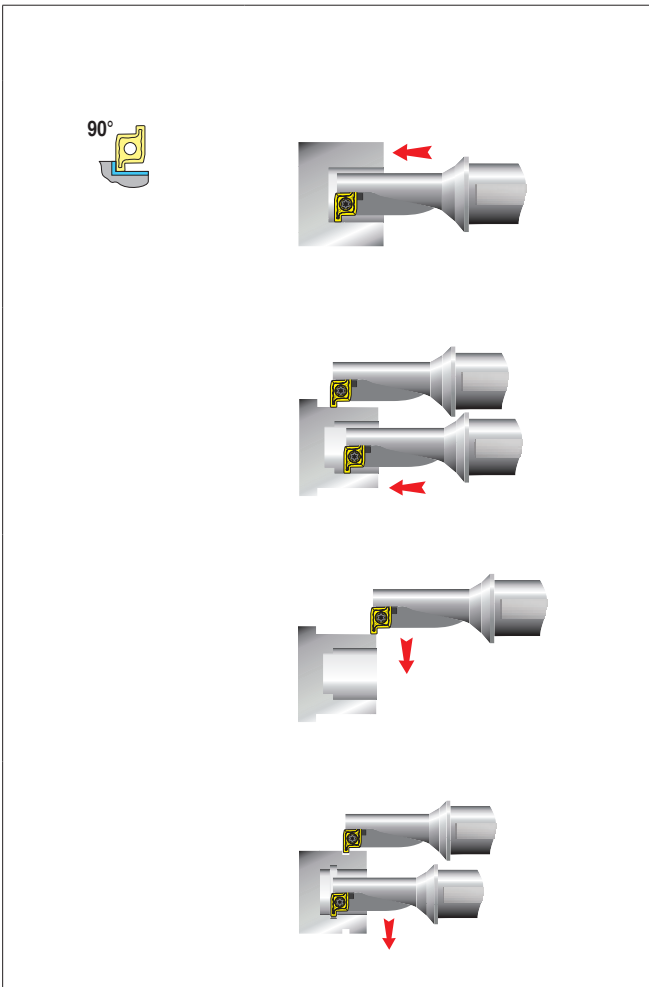

Machining methods - radial application 90°

Drilling into solid material with flat bottom holes

Boring applications

External turning applications

Internal turning applications

Turning of face profiles

External radial grooving

Internal radial grooving

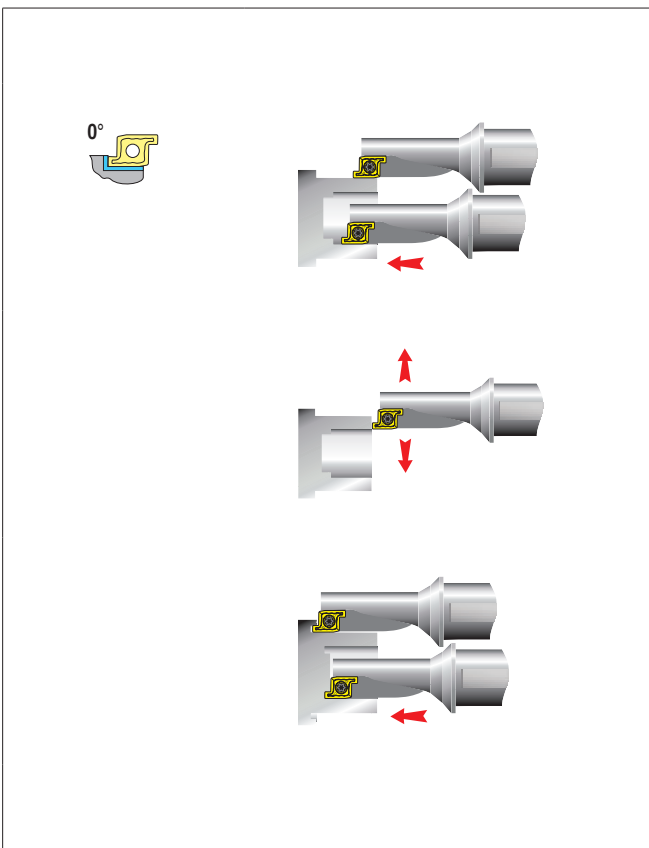

Machining methods - radial application 0°

External turning applications

Boring applications

Turning of face profiles

External radial grooving

Internal radial grooving



When changing from internal to external machining, reverse direction of rotation