

ProfileMaster

Axial grooving - application 0°

E32

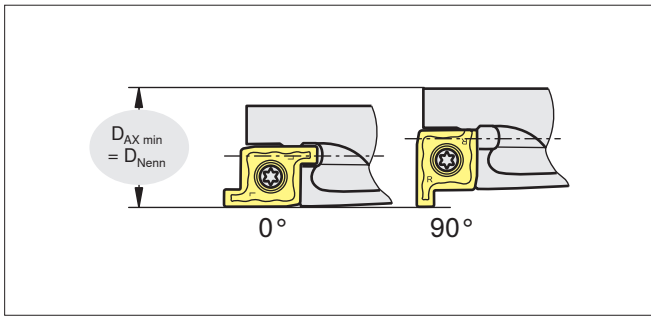

D_{Nenn}	D_{AXmin}	D_{AXmax}
16	16	∞
20	20	∞
25	25	∞
32	32	∞

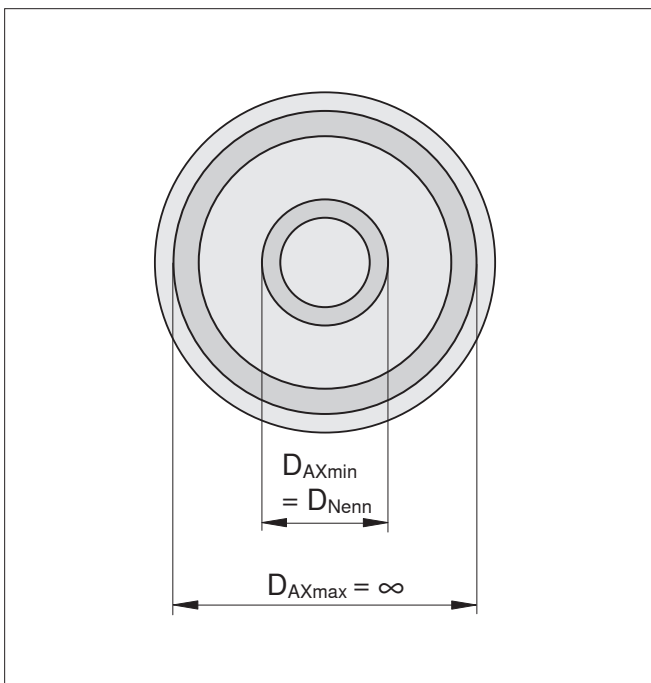
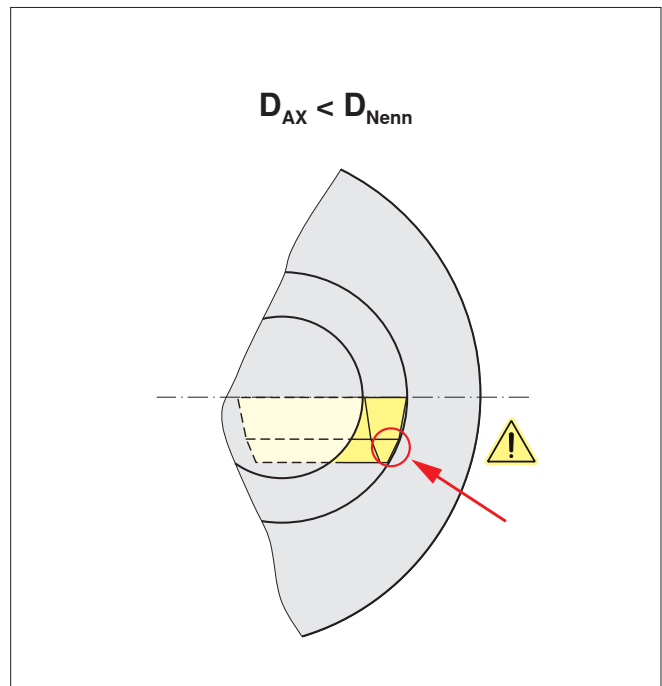
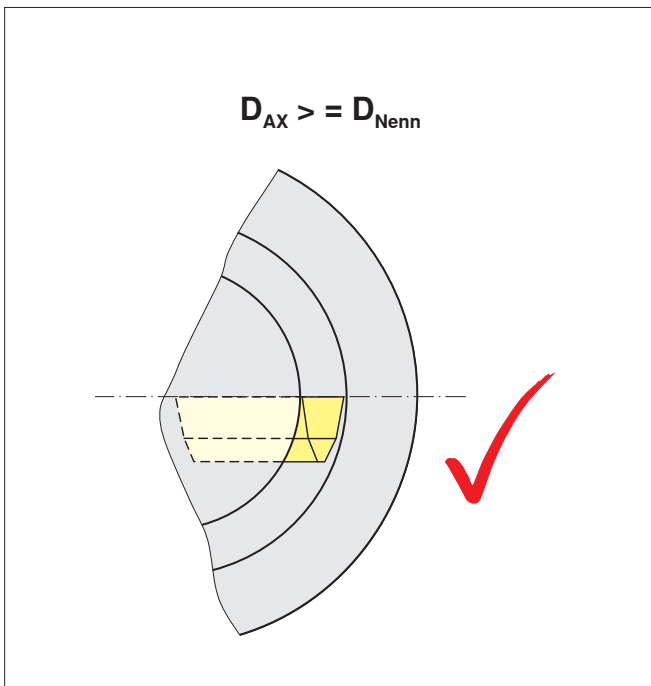

If the first cut is carried out with a diameter which is smaller than the nominal tool diameter D_{Nenn} (90° application), collision will result.