

# Machining example

E34

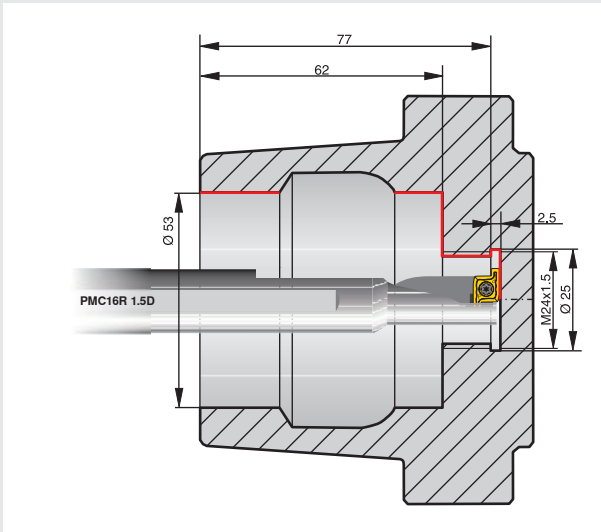

## Technical data

<b>Work piece</b>	HSK100 adapter
<b>Material</b>	1.2342 X38 CrMoV 5 1
<b>Tensile strength</b>	approx. 1100 N/mm <sup>2</sup>
<b>Tool</b>	PMC 16R-1.5D
<b>Insert</b>	PM 16RG 252004-M20 CTP2440
<b>Competitor</b>	2 tools

		CERATIZIT	
v <sub>c</sub>	[m/min]	150	
f	[mm]	0.15	
a <sub>p</sub>	[Ø mm]	1	

## Criteria

- Problems due to lack of turret positions
- Optimisation of machining time

## Result

- Only 1 tool instead of 2
- 1 free turret position