



CUTTING SOLUTIONS BY CERATIZIT

PROGRAMME EXTENSIONS

CUTTING TOOLS

2016.2

EN



Tools and Inserts for turning		
Introduction	Introduction	#R01#
	Inserts	#R02#
	Technical information	#R03#
Tools and inserts for milling		
Introduction	Introduction	#R01#
	Shoulder milling	#R02#
	Technical information	#R03#
Multi-function tools		
Introduction	Introduction	#R01#
	ProfileMaster	#R02#
Solid carbide tools		
Introduction	Introduction	#R01#
	Milling	#R02#
	Technical information	#R03#
Spindle nose tools		
Introduction	Introduction	#R01#
	Rotating spindle nose tools	#R02#
	Stationary spindle nose tools	#R03#
	Accessories	#R04#
	Technical information	#R05#
Index		
Index		#R01#

SERVICE

CERATIZIT website

Online service

Of course we are also available for you online – around the clock! On the new CERATIZIT website you will not only find details about our innovative products, but you can also order them.

Orders can be placed in our new and improved E-TECH-STORE. With the CONFIGURATE service you can even order customised semi-standard tools.

The new CERATIZIT website

CERATIZIT's website combines a modern design with increased user-friendliness making it easy and intuitive to use on mobile devices.

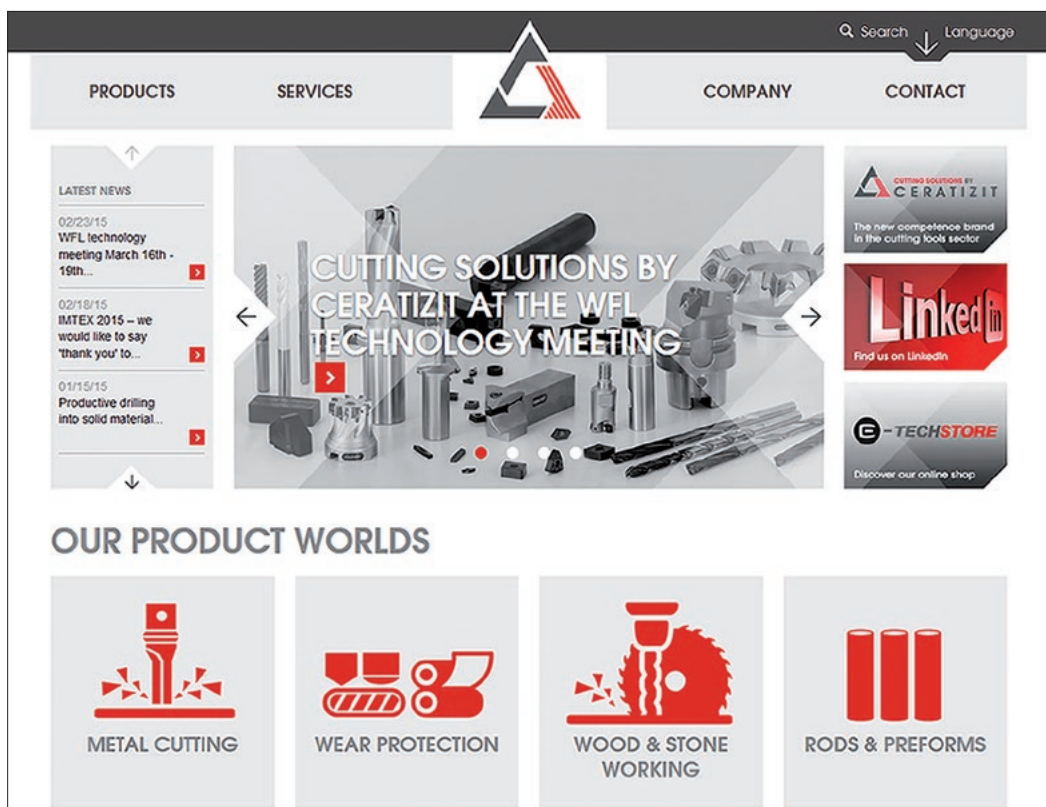

CERATIZIT Product Worlds

In our various Product Worlds, you have access to over 80 pages with product details on cutting tools, rods & preforms, wear protection and wood & stone machining. Discover product videos, application examples and success stories.



E-TECHSTORE

Our online shop offers more than 25,000 standard and special products: tools with inserts and solid carbide tools for the cutting tools sector as well as products for wood and stone machining, carbide rods, blanks for slitting knives, products for the tool and die industry and focusing tubes.

Order 24/7 and check availability for all products in real time.

Everything at a glance

See all important product information at a glance, including STEP files and an overview of all customer-specific online and offline transactions with CERATIZIT. Via the 'track & trace' feature you can view the progress of your order at any time. If required you have the possibility to get in touch directly with your individual contact person.



BASKET

CUTTING TOOLS / INSERTS (MM)

- ▶ Turning
- ▼ Milling
 - ▼ Tools
 - ▶ End mills
 - ▶ HelixMax cutter
 - ▶ Milling cutter with threaded shank
 - ▶ Monoblock HSK
 - ▼ Shell milling cutters
 - ▼ 45°
 - ▶ A270
 - ▶ **A271**
 - ▶ A273
 - ▶ A274
 - ▶ 75°
 - ▶ 90°
 - ▶ 0°
 - ▶ side & face milling cutters
 - ▶ Cartridge type cutter
 - ▶ Inserts
 - ▶ Drilling
 - ▶ Parting, grooving
 - ▶ Threading
 - ▶ Multi-function tools
 - ▶ Spare parts
 - ▶ Spindle nose tooling
 - ▶ System solutions
- SOLID CARBIDE TOOLS +
- SOLID CARBIDE TOOLS (CLASSICLINE) +
- RODS P-LINE +
- SLITTING KNIFE BLANKS +
- DIE AND MOLD INDUSTRY +
- FOCUSING TUBES +
- WOOD WORKING +

Home » Cutting tools / inserts (mm) » Milling » Tools » Shell milling cutters » 45° » A271

A271

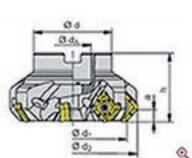

SERVICE NUMBER
Free phone service number

GB: 0800 048 4877
E: 0800 048 4877
US: +1 800 783 2280
CA: +1 800 783 2280

DOWNLOAD
Product list (.XLS)

Items per page: 1 until 5 from 8

Material no.	Description	d ₁ mm	d ₂ mm	h mm	d mm	d _A mm	a mm	z	n _{max} RPM
11681648	A271.100 R.08-17 Quantity(PCE): <input type="text" value="1"/>	100	116,1	50	78	32	8,4	8	9900
11681649	A271.125 R.10-17 Quantity(PCE): <input type="text" value="1"/>	125	141,1	63	88	40	8,4	10	8800
11696039	A271.160 R.12-17 Quantity(PCE): <input type="text" value="1"/>	160	176,1	63	104	40	8,4	12	7700
11718044	A271.200 R.13-17 Quantity(PCE): <input type="text" value="1"/>	200	216,1	63	134	60	8,4	13	6900
11718047	A271.250 R.15-17 Quantity(PCE): <input type="text" value="1"/>	250	266,1	63	134	60	8,4	15	6100

Items per page: 1 until 5 from 8

SERVICE

Configure

**CONFIGURATE****Your customised tool**

Using the online solution CONFIGURATE, it is possible to configure a customised semi-standard tool with only a few mouse clicks.

Thanks to the new CONFIGURATE tool we are able to offer simple and easy order processing of customised solid carbide tools. You can configure a customised semi-standard tool with just a few mouse clicks in our E-TECHSTORE – 24 hours a day, 7 days a week.

Your customised tool

- Offers and orders of individual tools - as fast and easy as for any standard tool.
- Availability 24 hours a day. Order regardless of business hours, thanks to fully automated processing.
- Easy to use thanks to menu-guided navigation: obtain your individual tool in just a few steps.
- Optimised for tablet PCs and smartphones.

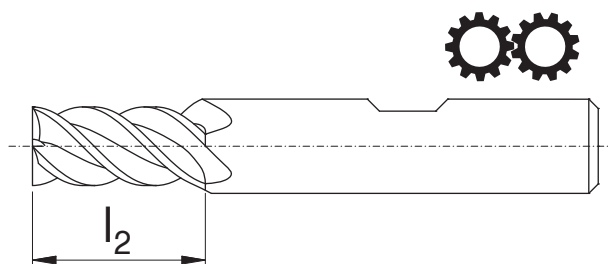
d₁ [mm]* 10,00**d₃ [mm]*** 9,50**l₁ [mm]*** 72,00**ST*** DIN6535HB **l₂ [mm]*** 15,00**l₃ [mm]*** 30,00**F [mm]*** 0,20**a [mm]*** 45,00

What to do:

- Log in as usual with your personal access data at e-techstore.com.
- Choose a basic product from our broad standard programme of solid carbide milling cutters and drills.
- Define your individual tool dimensions using the simple menu.
- The feasibility of your information will be verified at the touch of a button and you will receive scaled prices online for the quantity you require.
- You can see a true-to-scale 3D-model of your configured tool.
- Order your product immediately or receive a quotation.
- Within only a few minutes you will receive an e-mail with an order confirmation or an offer including price and delivery time. A drawing, a DXF-file and a true-to scale STEP volume model for collision analysis will also be sent to you.

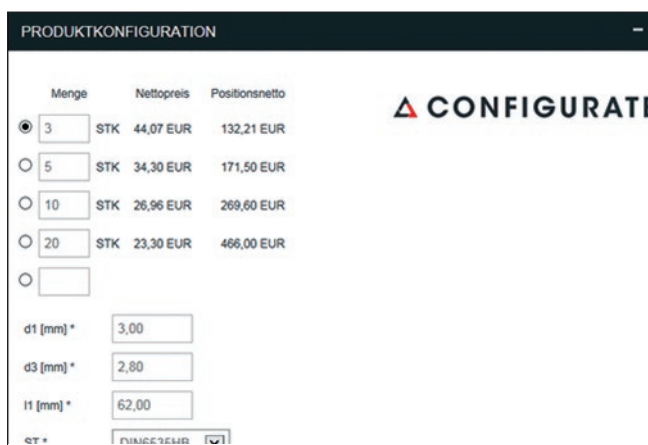
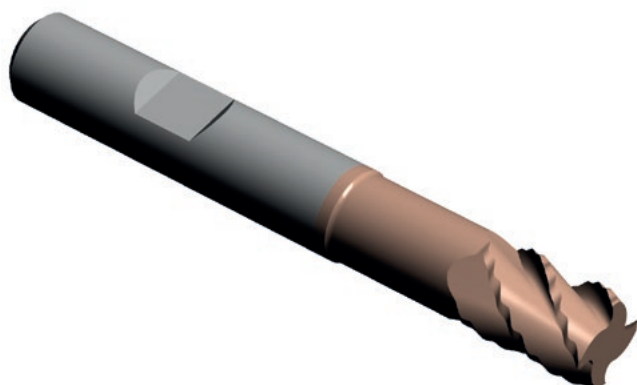
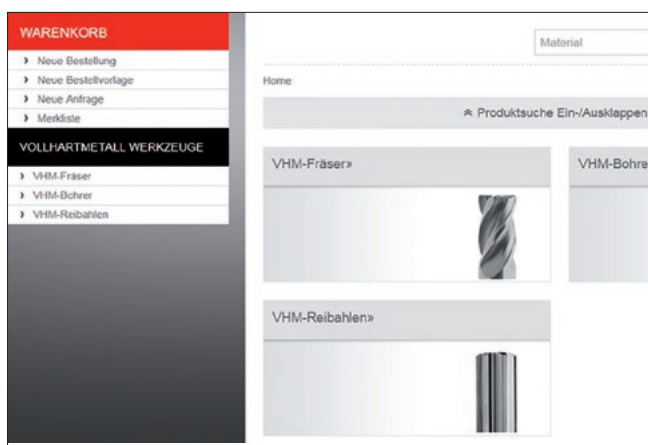
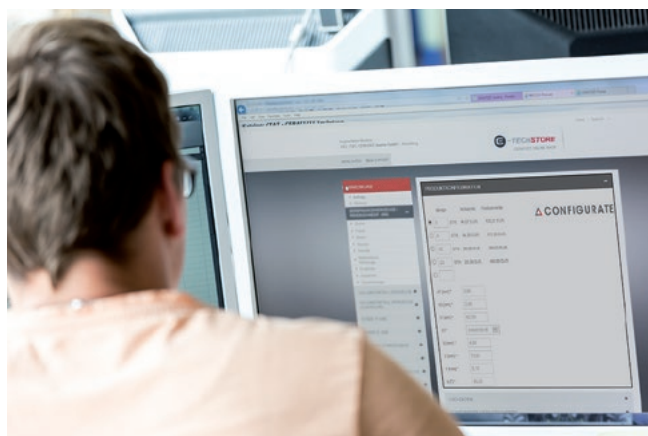

Any questions? Feel free to contact us!
E-mail: configure@ceratizit.com

SERVICE

IT connection



Easier to use

Thanks to the user-friendly design and intelligent navigation you will quickly and easily find the product information you need.

We have simplified the ordering process. Recurring orders are now also possible. Furthermore we have optimised our shop for use with tablet PCs and smartphones.

In the new profile area you can manage your personal data.

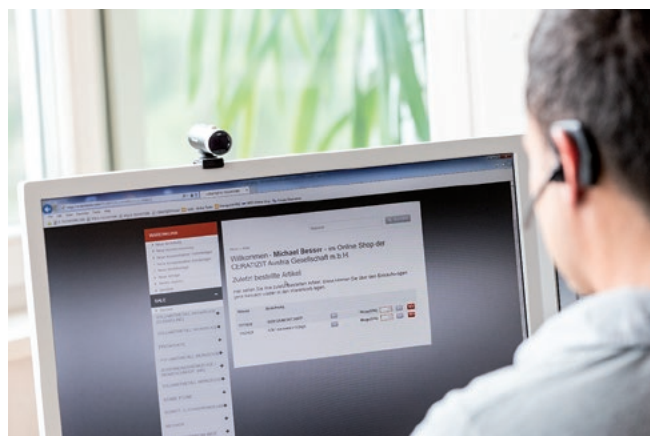

Connection to your system

Want to connect your ERP system to our shop? No problem! Our e-commerce team will be happy to help. Our IT supports all common linkage formats (EDI, XML, OCI, etc.).

Don't hesitate to contact us! Our technical engineer will analyse your requirements together with you and will help you to choose the right technology.



Any questions? Feel free to contact us!

E-mail: esolutions@ceratizit.com

Tooling Academy

Get to know your tools in detail – watch them during the respective applications on machines which today are used in all production departments. To do so, we have established up-to-date machining centres for tests and training courses and the latest analysis technology at our Tooling Academy. In collaboration with you, we analyse the machinability of the materials and work pieces. Based on the findings of simulations and practical tests, we then deduce specific tool recommendations or develop specific tool solutions for you.

We have opened our first Tooling Academy in Reutte, Austria – our centre of excellence for cutting solutions. For us to also be close to our Asian customers, we have had our second Tooling Academy in Tianjin, China since 2011.

Modern equipment

Seven high-tech lathes and milling machines stand at the ready in the Tooling Academy in Reutte. Tianjin is equipped with three metal cutting machines.

- 3- and 5-axis milling machine
- HSC milling centre
- Bed-type milling machine
- Heavy milling machine
- Lathe
- Turn-mill centre
- Heavy lathe
- NC turret lathe

Additionally, we apply the latest in high-speed camera technology in order to view the machining processes in extreme slow motion. In this way, we receive detailed information about the entire machining process.



Introduction

The CERATIZIT grade universe

10



The new CERATIZIT grade universe

As one of the most competent partners when it comes to cutting tools technology, CERATIZIT continuously optimises and revises the grade range for milling, drilling, turning, parting and grooving.

The universe

Within the universe, several galaxies represent the applications (milling, turning, drilling, parting and grooving). Every galaxy then consists of single solar systems. Each of these systems contains their own solutions for special requirements. Immersing ourselves deeper into the planetary systems, and taking a closer look at the planets they reveal themselves as our unique grade coatings - the 'Stars'.

The 'STARS'

Each of the STARS is easily recognisable by the colour of its coating and shows its strengths in the machining of specific materials and in determined applications.



BLACKSTAR™

The BLACKSTAR™ grades are highly wear-resistant thanks to their TiN/TiCN/Al₂O₃ coatings. Due to their excellent adhesion, these coatings are particularly suitable for the machining of steel and cast iron.

SILVERSTAR™

For high cutting performance in interrupted cutting actions or with difficult to machine materials, SILVERSTAR™ grades are the first choice.

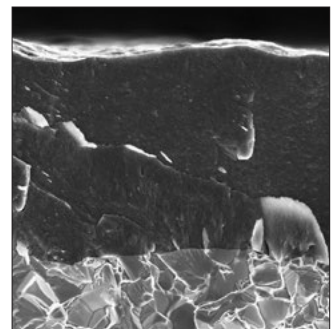
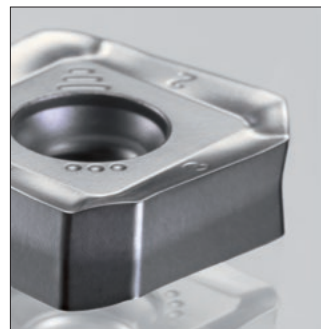
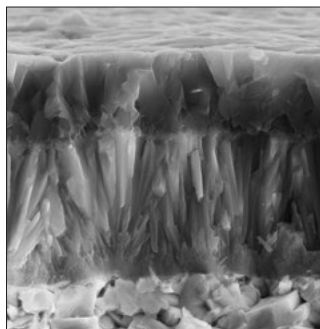
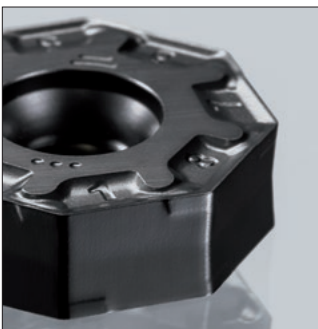



GOLDSTAR™

This all-rounder among coatings is suitable for a variety of machining operations and numerous materials. GOLDSTAR™ is characterised by the diverse application possibilities and good wear recognition through the golden-yellow colour.

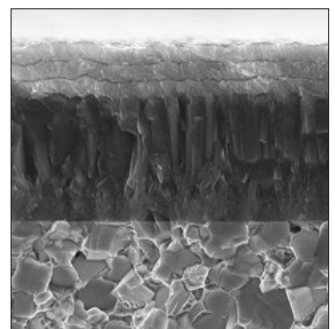
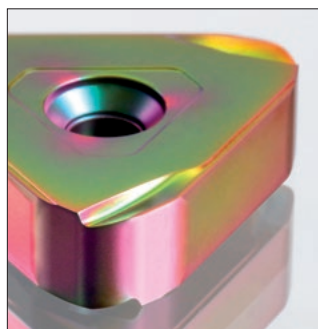
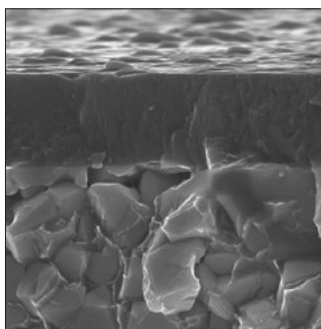
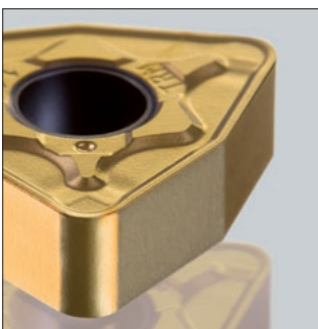

COLORSTAR™

When a combination of wear resistance and toughness is required, the multi-oxide layers of COLORSTAR™ can demonstrate their strengths. They increase reliability and edge stability with medium to high cutting speeds.





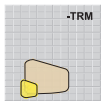

Introduction

	Product extensions	#R01#
	Grade overview and description	#R02#
	Chip grooves	#R03#

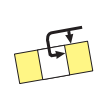
Inserts

	MaxiLock D/N	#R01#
---	--------------	-------

Technical information

	Cutting data	#R01#
---	--------------	-------

Index

	Index	#R01#
---	-------	-------

Turning

Extended product range



CERATIZIT 3x3 - the complete package for the turning of steel

Turning of steel is one of the most frequent machining operations. To meet the many requirements in this field, a wide range of grades, geometries and tools is necessary. Finding

an optimal solution can be a challenge here.

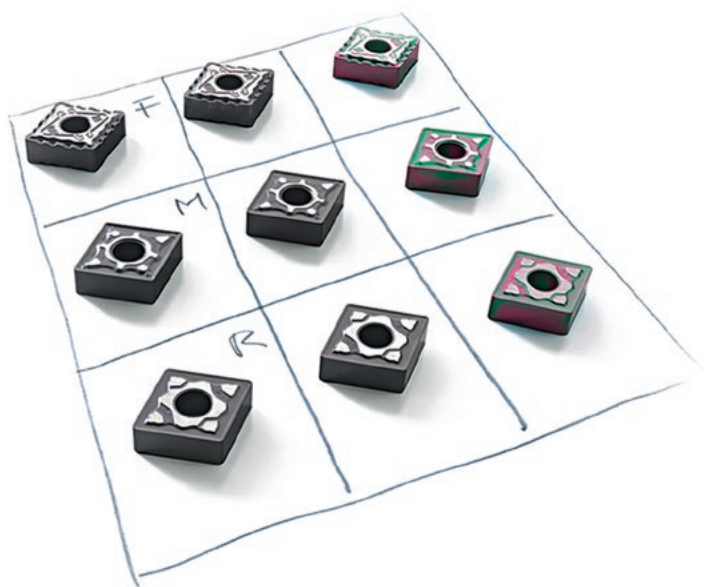

An intelligent combination - this is how you achieve maximum productivity

Discover our new CERATIZIT 3x3. From now on we offer you an innovative total package for the turning of steel. Choose the most economical solution from an extremely well-structured product portfolio.

For every requirements profile our 3x3 will reliably and quickly tell you the intelligent combination of grade, chip groove and machining parameters. In this way you always receive the best suited tool for achieving maximum productivity. From roughing to finishing you will come a very big step closer to the optimum. Try for yourself! All important information can be found on the following pages...

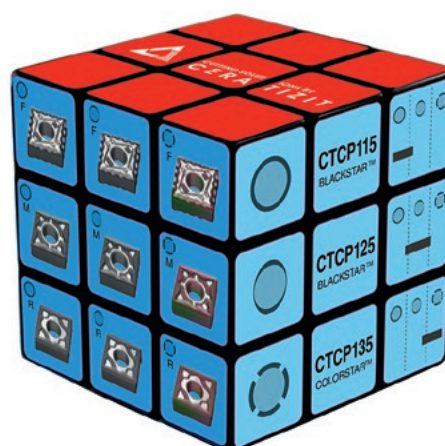

CERATIZIT 3x3: 3 grades - 3 chip grooves

With the introduction of the new finishing geometry -F50 the entire steel machining range has been revised. With 3 grades and 3 chip grooves all machining situations for steel are covered.

This user-friendly concept enables quick selection of a suitable combination of grades and geometries for any kind of machining situation.

	P15	P25	P35
F	-F50 CTCP115	-F50 CTCP125	-F50 CTCP135
M	-M50 CTCP115	-M50 CTCP125	-M50 CTCP135
R	-M70 CTCP115	-M70 CTCP125	-M70 CTCP135

Your advantages

- ▲ Three grades cover all steel machining applications
- ▲ Complete, well-structured programme
- ▲ BLACKSTAR™ CTCP115 – highly wear-resistant grade for high cutting parameters
- ▲ BLACKSTAR™ CTCP125 - universal grade for all applications including slightly interrupted cut
- ▲ COLORSTAR™ CTCP135 – tough grade for interrupted cut and difficult conditions
- ▲ Ground contact face

Your benefits

- ▲ Reduced stock inventory, resulting in lower costs
- ▲ Easy selection of the correct insert
- ▲ For a wide application field in steel machining
- ▲ For maximum process security and consistent quality
- ▲ Higher mechanical stability of the tool holder ensures process security even under extremely difficult machining conditions

The 3 grades

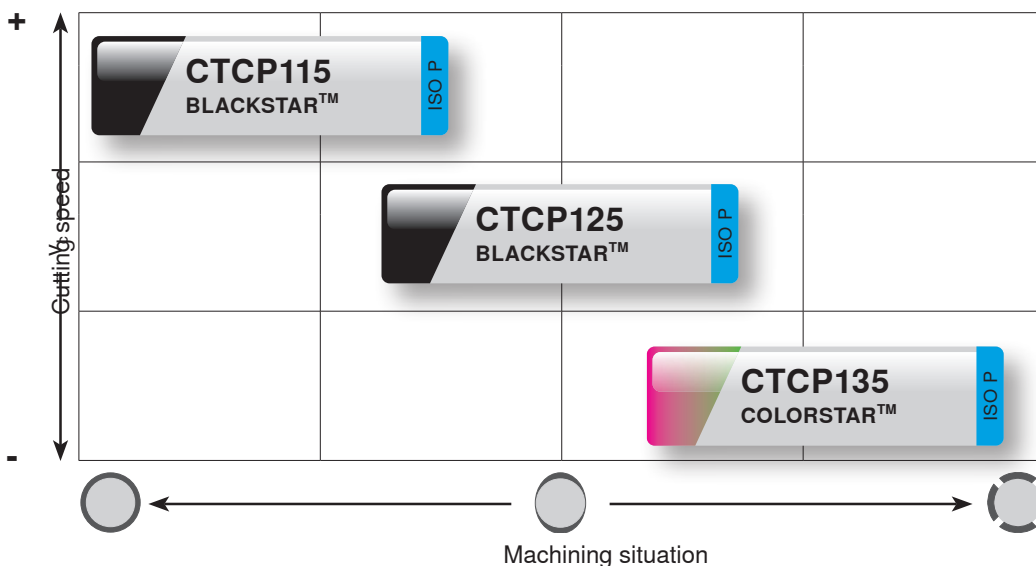







Turning

Extended product range



The 3 chip grooves

<p>-F50 the fine-cutting chip groove</p>	<p>F</p>		
<p>-M50 the universal chip groove</p>	<p>M</p>		
<p>-M70 the stable chip groove</p>	<p>R</p>		

Negative inserts

With only 3 chip grooves, the new 3x3 concept focuses on a targeted selection of the right insert: -F50 for finishing, -M50 for medium machining and -M70 for roughing. The user-friendly concept thus offers you perfectly adapted

chip grooves for all applications and machining situations in the field of steel turning.

-F50



- ▲ Chip groove for finish-machining of steels and stainless steels
- ▲ Very good chip control
- ▲ High surface quality

-M50



- ▲ Medium machining
- ▲ First choice for steel machining
- ▲ Universal application
- ▲ Wide application range

-M70



- ▲ Light to medium-rough machining
- ▲ Interrupted cut
- ▲ Cast skin and forging skin
- ▲ Blanks and forged parts

The new -F50

The finishing geometry -F50 for steel and stainless steel is new in the range and completes CERATIZIT 3x3. It offers excellent chip control together with a high surface quality. The ground contact face increases stability. The sharp cutting edge

guarantees a smooth cut and low cutting forces.

BLACKSTAR™

COLORSTAR™

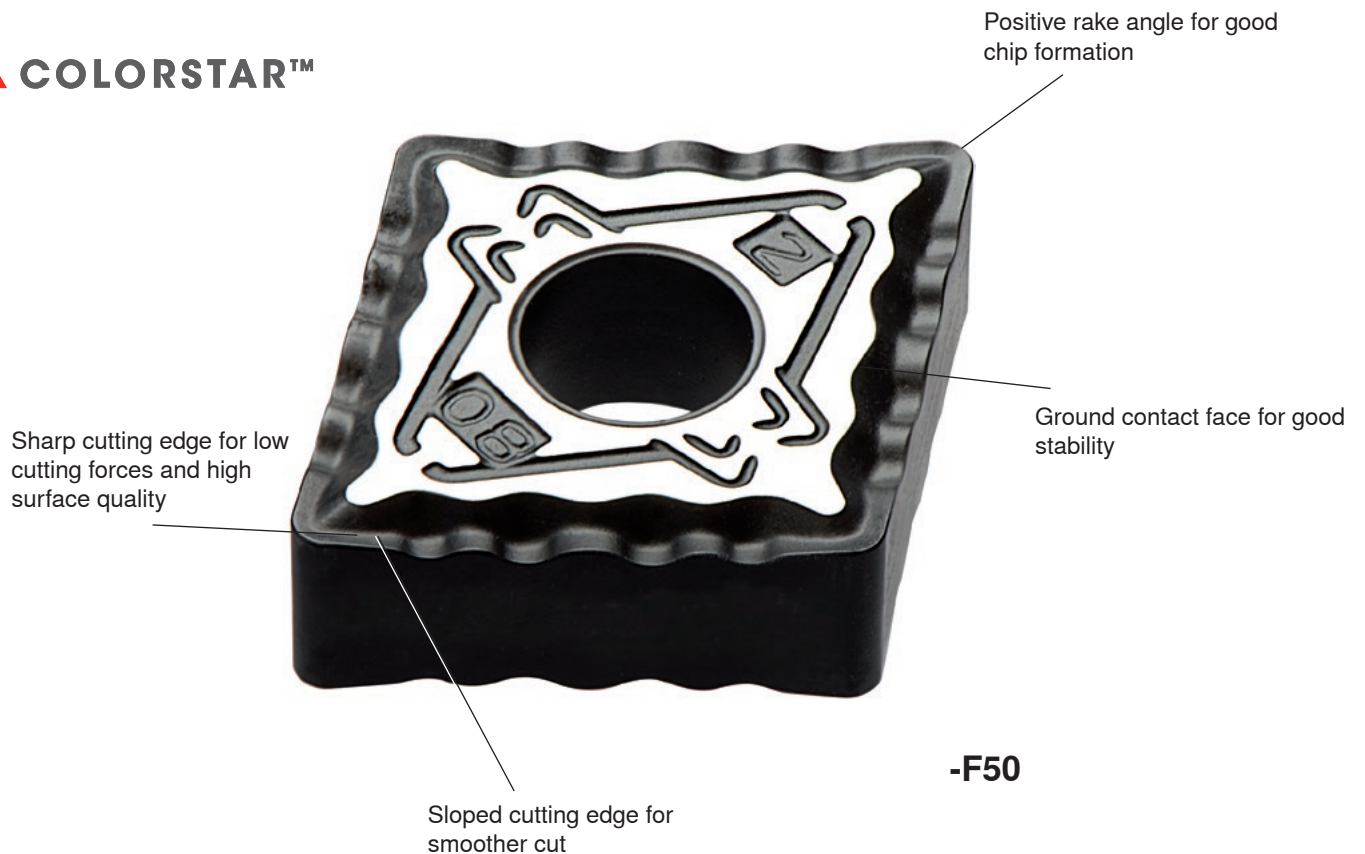



A practical example

Work piece: bearing / 100Cr6

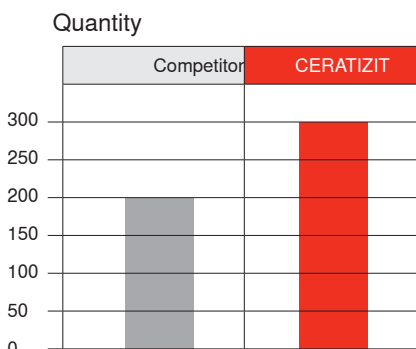
Cutting data	Competitor	CERATIZIT
Geometry	–	-F50
Grade	–	CTCP125
v_c (m/min)	250	300
f (mm/rev)	0,2 – 0,3	0,3 – 0,35
a_p (mm)	1	1
Quantity	200	300

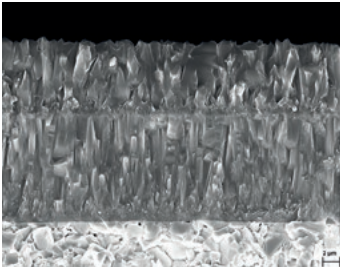

CTCP115	HC-P15 HC-K25 HC-M10	
	<p>Specification: Composition: Co 5.8%; mixed carbides 6.4%; WC balance Grain size: 1 - 2 μm Hardness: HV₃₀ 1550 Coating specification: CVD TiCN-Al₂O₃</p> <p>Recommended application: The wear-resistant high-performance grade for steel machining.</p>	

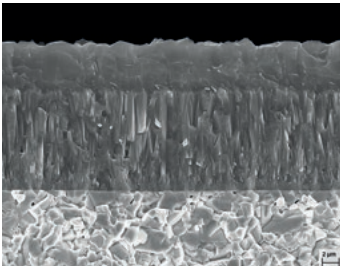
CTCP125	HC-P25 HC-K30 HC-M20	
	<p>Specification: Composition: Co 7.0%; mixed carbides 8.0%; WC balance Grain size: 1 - 2 μm Hardness: HV₃₀ 1450 Coating specification: CVD TiCN-Al₂O₃</p> <p>Recommended application: The first choice for the universal machining of steel.</p>	

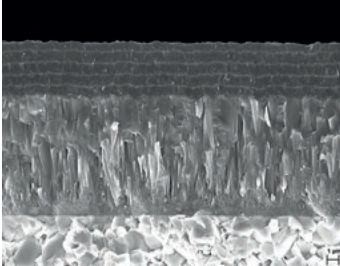
CTCP135	HC-P35 HC-M25 HC-S25	
	<p>Specification: Composition: Co 9.6%; mixed carbides 6.7%; WC balance Grain size: 1 - 2 μm Hardness: HV₃₀ 1460 Coating specification: CVD TiCN-Al₂O₃ multi-layer</p> <p>Recommended application: The tough alternative for heavily interrupted cutting action.</p>	

Chip grooves for negative/positive inserts

A10







-F50

- Chip groove for finish machining
- Steel and stainless steel
- Very good chip control
- High surface quality

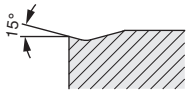
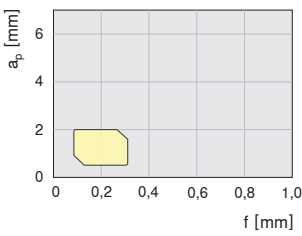

CNMG 120408..

Machining conditions		
		
CTCP115	CTCP125	CTCP135
CTCP115	CTCP125	CTCP135



-M50

- Medium machining
- First choice for steel machining
- Universal application

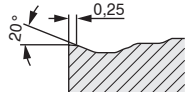
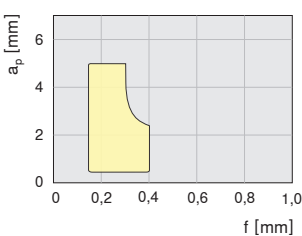

CNMG 120408..

Machining conditions		
		
CTCP115	CTCP125	CTCP135
CTCP115	CTCP135	CTCP135
CTCK110	CTCK120	CTCK120



-M70

- Light to medium roughing
- Cast skin and forging skin
- Stable cutting edge
- Interrupted cut
- For blanks and forged parts

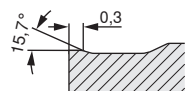
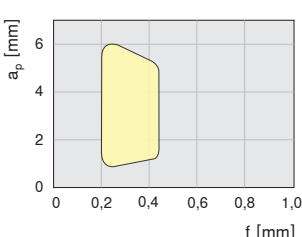

CNMG 120408..

Machining conditions		
		
CTCP115	CTCP125	CTCP135
CTCP125	CTC2135	CTC2135
CTCK110 CTCP115	CTCK120	CTCK120

			CTCP115			CTCP125			CTCP135			d	l	s	r	d ₁
-F50		CNMG 090304EN-F50	●	●	●	●	●	●	●	●	●	9.52	9.70	3.18	0.40	3.81
		CNMG 090308EN-F50	●	●	●	●	●	●	●	●	●	9.52	9.70	3.18	0.80	3.81
		CNMG 120404EN-F50	●	●	●	●	●	●	●	●	●	12.70	12.90	4.76	0.40	5.16
		CNMG 120408EN-F50	●	●	●	●	●	●	●	●	●	12.70	12.90	4.76	0.80	5.16
		CNMG 120412EN-F50	●	●	●	●	●	●	●	●	●	12.70	12.90	4.76	1.20	5.16
-M50		CNMG 120404EN-M50	●	●	●	●	●	●	●	●	12.70	12.90	4.76	0.40	5.16	
		CNMG 120408EN-M50	●	●	●	●	●	●	●	●	12.70	12.90	4.76	0.80	5.16	
		CNMG 120412EN-M50	●	●	●	●	●	●	●	●	12.70	12.90	4.76	1.20	5.16	
		CNMG 120416EN-M50	●	●	●	●	●	●	●	●	12.70	12.90	4.76	1.60	5.16	
		CNMG 160608EN-M50	●	●	●	●	●	●	●	●	15.88	16.10	6.35	0.80	6.35	
		CNMG 160612EN-M50	●	●	●	●	●	●	●	●	15.88	16.10	6.35	1.20	6.35	
-M70		CNMG 160616EN-M50	●	●	●	●	●	●	●	15.88	16.10	6.35	1.60	6.35		
		CNMG 120408EN-M70	●	●	●	●	●	●	●	●	12.70	12.90	4.76	0.80	5.16	
		CNMG 120412EN-M70	●	●	●	●	●	●	●	●	12.70	12.90	4.76	1.20	5.16	
		CNMG 120416EN-M70	●	●	●	●	●	●	●	●	12.70	12.90	4.76	1.60	5.16	
		CNMG 160608EN-M70	●	●	●	●	●	●	●	●	15.88	16.10	6.35	0.80	6.35	
		CNMG 160612EN-M70	●	●	●	●	●	●	●	●	15.88	16.10	6.35	1.20	6.35	
		CNMG 160616EN-M70	●	●	●	●	●	●	●	●	15.88	16.10	6.35	1.60	6.35	
		CNMG 190612EN-M70	●	●	●	●	●	●	●	●	19.05	19.30	6.35	1.20	7.94	
		CNMG 190616EN-M70	●	●	●	●	●	●	●	●	19.05	19.30	6.35	1.60	7.94	
		CNMG 190624EN-M70	●	●	●	●	●	●	●	●	19.05	19.30	6.35	2.40	7.94	
-F50		CNMG 250924EN-M70	●	●	●	●	●	●	●	25.40	25.80	9.52	2.40	9.12		
		DNMG 110404EN-F50	●	●	●	●	●	●	●	9.52	11.60	4.76	0.40	3.81		
		DNMG 110408EN-F50	●	●	●	●	●	●	●	9.52	11.60	4.76	0.80	3.81		
		DNMG 110412EN-F50	●	●	●	●	●	●	●	9.52	11.60	4.76	1.20	3.81		
		DNMG 150404EN-F50	●	●	●	●	●	●	●	12.70	15.50	4.76	0.40	5.16		
		DNMG 150408EN-F50	●	●	●	●	●	●	●	12.70	15.50	4.76	0.80	5.16		
		DNMG 150412EN-F50	●	●	●	●	●	●	●	12.70	15.50	4.76	1.20	5.16		
		DNMG 150604EN-F50	●	●	●	●	●	●	●	12.70	15.50	6.35	0.40	5.16		
		DNMG 150608EN-F50	●	●	●	●	●	●	●	12.70	15.50	6.35	0.80	5.16		
-M50		DNMG 150612EN-F50	●	●	●	●	●	●	12.70	15.50	6.35	1.20	5.16			
		DNMG 110404EN-M50	●	●	●	●	●	●	●	9.52	11.60	4.76	0.40	3.81		
		DNMG 110408EN-M50	●	●	●	●	●	●	●	9.52	11.60	4.76	0.80	3.81		
		DNMG 110412EN-M50	●	●	●	●	●	●	●	9.52	11.60	4.76	1.20	3.81		
		DNMG 150404EN-M50	●	●	●	●	●	●	●	12.70	15.50	4.76	0.40	5.16		
		DNMG 150408EN-M50	●	●	●	●	●	●	●	12.70	15.50	4.76	0.80	5.16		
		DNMG 150412EN-M50	●	●	●	●	●	●	●	12.70	15.50	4.76	1.20	5.16		
		DNMG 150416EN-M50	●	●	●	●	●	●	●	12.70	15.50	4.76	1.60	5.16		
		DNMG 150604EN-M50	●	●	●	●	●	●	●	12.70	15.50	6.35	0.40	5.16		
		DNMG 150608EN-M50	●	●	●	●	●	●	●	12.70	15.50	6.35	0.80	5.16		
		DNMG 150612EN-M50	●	●	●	●	●	●	●	12.70	15.50	6.35	1.20	5.16		
		DNMG 150616EN-M50	●	●	●	●	●	●	●	12.70	15.50	6.35	1.60	5.16		

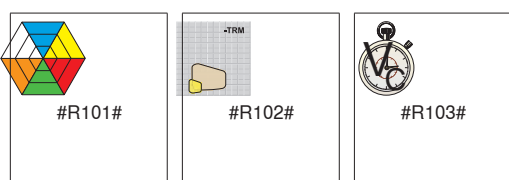
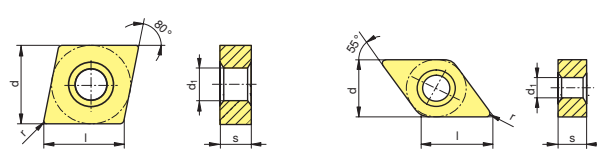

MaxiLock D/N

WN..



	P	M	K	N	S	H				d	l	s	r	d ₁
							CTCP115	CTCP125	CTCP135	[mm]	[mm]	[mm]	[mm]	[mm]
-F50		VNMG 160404EN-F50	●	○	○	○	●	●	●	9.52	16.60	4.76	0.40	3.81
		VNMG 160408EN-F50	●	○	○	○	●	●	●	9.52	16.60	4.76	0.80	3.81
-M50		VNMG 160404EN-M50	●	○	○	○	●	●		9.52	16.60	4.76	0.40	3.81
		VNMG 160408EN-M50	●	○	○	○	●	●		9.52	16.60	4.76	0.80	3.81
		VNMG 160412EN-M50	●	○	○	○	●	●		9.52	16.60	4.76	1.20	3.81
-F50		WNMG 060404EN-F50	●	○	○	○	●	●		9.52	6.50	4.76	0.40	3.81
		WNMG 060408EN-F50	●	○	○	○	●	●		9.52	6.50	4.76	0.80	3.81
		WNMG 080404EN-F50	●	○	○	○	●	●		12.70	8.69	4.76	0.40	5.16
		WNMG 080408EN-F50	●	○	○	○	●	●		12.70	8.69	4.76	0.80	5.16
		WNMG 080412EN-F50	●	○	○	○	●	●		12.70	8.69	4.76	1.20	5.16
-M50		WNMG 060404EN-M50	●	○	○	○	●	●		9.52	6.50	4.76	0.40	3.81
		WNMG 060408EN-M50	●	○	○	○	●	●		9.52	6.50	4.76	0.80	3.81
		WNMG 060412EN-M50	●	○	○	○	●	●		9.52	6.50	4.76	1.20	3.81
		WNMG 080404EN-M50	●	○	○	○	●	●		12.70	8.69	4.76	0.40	5.16
		WNMG 080408EN-M50	●	○	○	○	●	●		12.70	8.69	4.76	0.80	5.16
		WNMG 080412EN-M50	●	○	○	○	●	●		12.70	8.69	4.76	1.20	5.16
		WNMG 080416EN-M50	●	○	○	○	●	●		12.70	8.69	4.76	1.60	5.16
-M70		WNMG 060408EN-M70	●	○	○	○	●	●		9.52	6.50	4.76	0.80	3.81
		WNMG 060412EN-M70	●	○	○	○	●	●		9.52	6.50	4.76	1.20	3.81
		WNMG 080408EN-M70	●	○	○	○	●	●		12.70	8.69	4.76	0.80	5.16
		WNMG 080412EN-M70	●	○	○	○	●	●		12.70	8.69	4.76	1.20	5.16
		WNMG 080416EN-M70	●	○	○	○	●	●		12.70	8.69	4.76	1.60	5.16
							CTCP115	CTCP125	CTCP135					

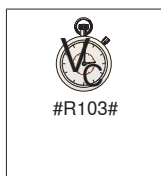
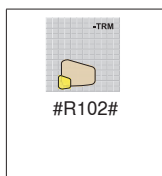
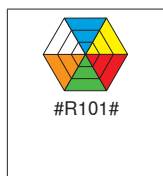
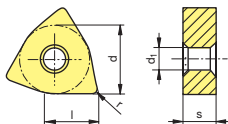
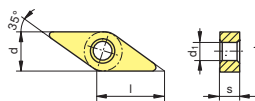

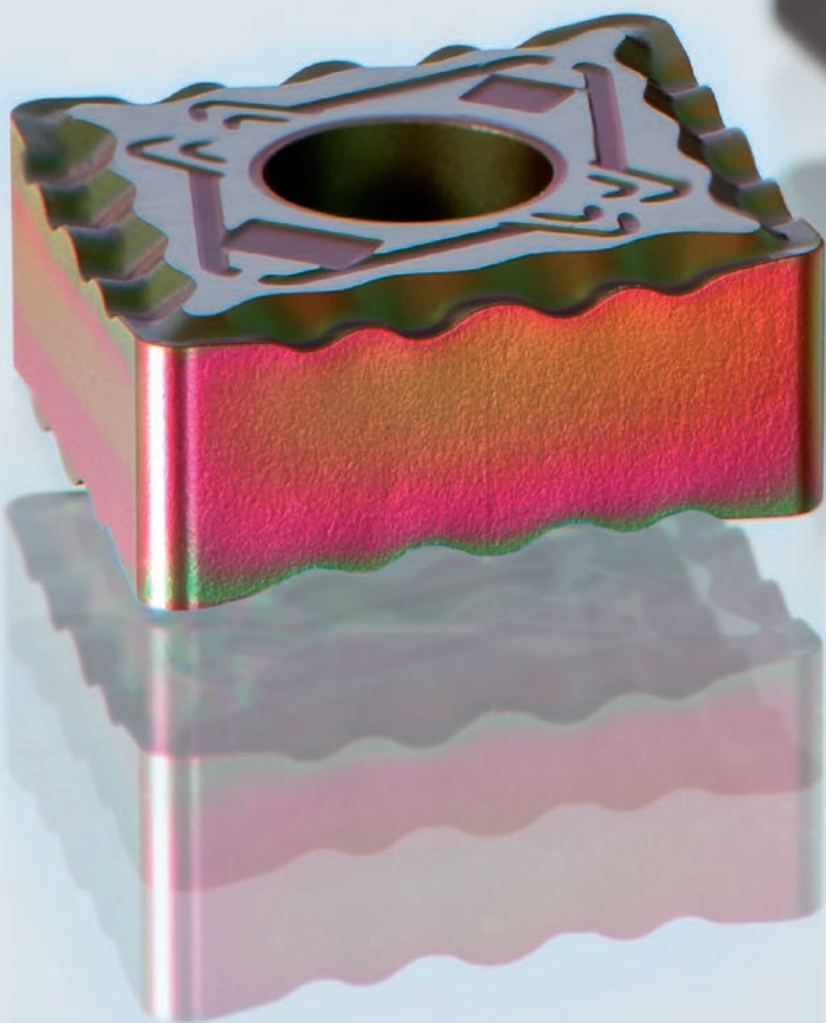

Cutting data

A16





	Work piece material	Type of treatment / alloy		VDI 3323 group	Hardness HB
P	Non alloyed steel	annealed	≤ 0.15 % C	1	125
		annealed	0.15 % - 0.45 % C	2	150 - 250
		tempered	≥ 0.45 % C	3	300
	Low alloyed steel	annealed		6	180
		tempered		7 / 8	250 - 300
		tempered		9	350
	High alloyed steel	annealed		10	200
		tempered		11	350
	Stainless steel	annealed	ferritic / martensitic	12	200
		tempered	martensitic	13	325
heat-treated		ferritic / martensitic	13	200	
M	Stainless steel	quenched	austenitic	14	180
		quenched	ferritic / austenitic (Duplex)	14	230 - 260
		hardened	austenitic, precipitation hardened (PH)	14	330
K	Grey cast iron		pearlitic / ferritic	15	180
			pearlitic / martensitic	16	260
	Spheroidal cast iron		ferritic	17	160
			pearlitic	18	250
	Malleable cast iron		ferritic	19	130
		pearlitic	20	230	
N	Aluminium wrought alloys	non hardened		21	60
		hardened		22	100
	Aluminium cast alloys	non hardened	< 12 % Si	23	75
		hardened	< 12 % Si	24	90
		non hardened	> 12 % Si	25	130
	Copper and copper alloys (bronze, brass)		machining alloy stock (1% Pb)	26	(110)
			brass, red bronze	27	90
			bronze	28	100
			lead-free copper and electrolytic copper	28	100
	Non-metallic materials		thermosetting plastics	29	-
			fibre-reinforced plastics	29	-
		hard rubber	30	-	
S	Heat-resistant alloys	annealed	Fe-base	31	200
		hardened	Fe-base	32	280
		annealed	Ni or Co-base	33	250
		hardened	Ni or Co-base 30 - 58 HRC	34	(350)
		cast	Ni or Co-base 1500 - 2200 N/mm ²	35	(320)
	Titanium alloys		pure titanium	36	R _m 440*
		alpha + beta alloys	37	R _m 1050*	
H	Tempered steel	hardened and tempered		38	55 HRC
		hardened and tempered		39	60 HRC
	Chilled castings	cast		40	400
	Tempered cast iron	hardened and tempered		41	55 HRC

* R_m = ultimate tensile strength, measured in MPa





Introduction

	Product extensions	#R01#
	Grade overview and description	#R02#

Types of milling

	MaxiMill 491 shoulder milling	#R01#
---	-------------------------------	-------

Technical information

	Cutting data	#R01#
	Spare parts	#R02#

Index

	Index	#R01#
---	-------	-------

Milling

Extended product range

B4



MaxiMill 491 The new 90° shoulder milling system

The new MaxiMill 491 shoulder milling system from Cutting Solutions by CERATIZIT features 8 usable cutting edges per insert and shows excellent performance, quality and price-performance ratio.

Thanks to the latest grinding technology, the precision inserts can be produced with tolerance H. This enhances the service life of the cutting edge, allowing top-quality surfaces to be achieved on your component.

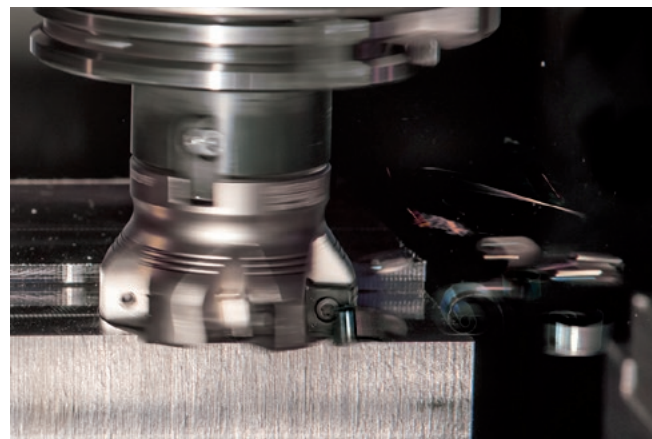

Reduced vibration is a particular advantage when it comes to low-power machines and thin-walled, unstable components.

Quick and easy insert mounting

Durable tool body in new material and 'Hard & Tough' coating

Tools available with close or wide pitch

Exact 90° profile

TorxPlus

Chamfered coolant holes suitable for MQL, emulsion and compressed air



Your advantages

- ▲ Exact 90° profile with 8 usable cutting edges per insert
- ▲ Ground precision insert with tolerance H
- ▲ Smooth cut with low power consumption
- ▲ Outstanding surface quality
- ▲ Universal application (e.g. face milling, shoulder milling, peripheral milling, slot milling, trochoidal slot milling)
- ▲ Tools with irregular pitch for minimum vibration during the milling operation
- ▲ Optimum chip evacuation
- ▲ Coolant arrives directly on the cutting edge; emulsion, MQL or compressed air can be used

Your benefits

- ▲ Excellent economic efficiency regarding the price per cutting edge for 90° shoulder milling
- ▲ Exact 90° profile
- ▲ Perfect axial run-out precision and concentricity
- ▲ Very good suitability for low-power machines
- ▲ Quick and easy loading of the milling cutter possible



Maximum repeatability thanks to innovative insert design with generous contact faces



Perfectly adapted chip pockets

A practical example

Spheroidal cast iron

	Competitor	CERATIZIT
Milling cutter	–	A491.80.R.08-12
Insert	–	SNHU 12048SR-R50
Grade	–	CTPK220
Cutting edge/insert	4	8
V_c [m/min]	301	301
V_f [mm/rev]	1200	1200
a_p [mm]	0,5	0,5
Quantity	100	120

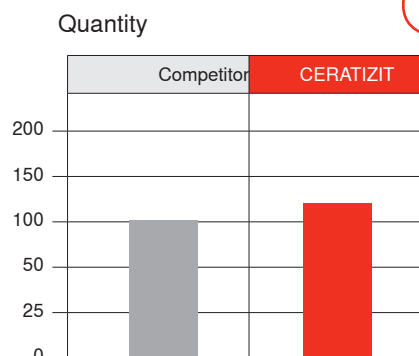

Milling

Extended product range

B6



Insert start programme

The insert start programme for ISO P steel, ISO K cast iron and ISO M stainless steel machining features the latest BLACKSTAR™ and SILVERSTAR™ manufacturing technology. For the machining of aluminium, the proven CTWN215 grade is used.

▲ Extended range of corner radii 1.2 mm - 1.6 mm - 2.0 mm

In addition to corner radius 0.8 mm the product range has been extended with the corner radii 1.2 mm, 1.6 mm and 2.0 mm.



▲ BLACKSTAR™

▲ SILVERSTAR™

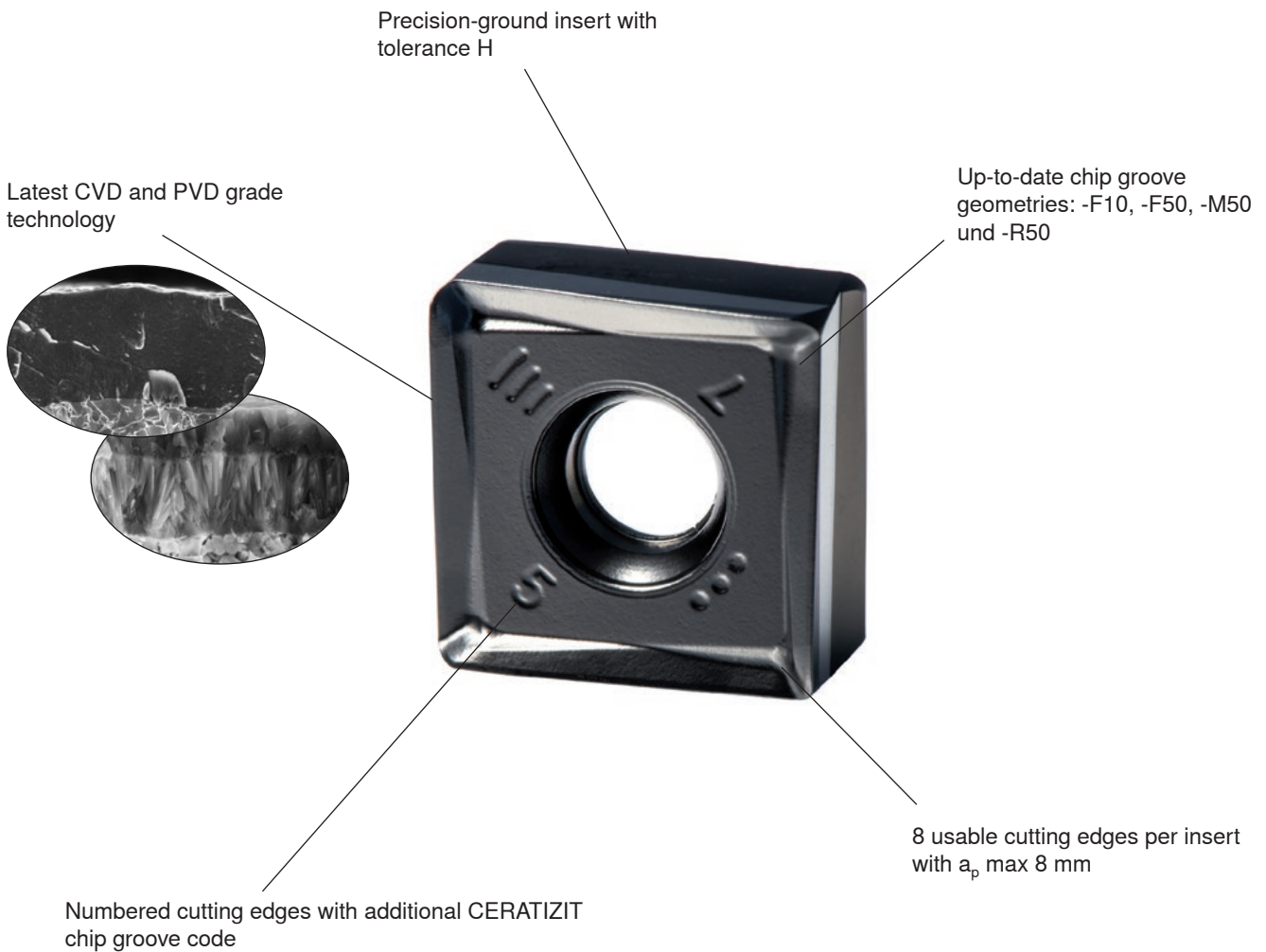

MaxiMill 491 - product launch

The product launch of MaxiMill 491 will start with a 12 mm assembly size and includes \varnothing ranging from 32-160 mm. Cutting Solutions by CERATIZIT offers you shell milling cutters, end mills and milling cutters with threaded shank. The end milling cutters are available with a wide or narrow pitch. The

F-M-R chip grooves combined with the latest grade technology cover applications for a variety of materials ranging from steel to cast iron, stainless steels (ISO P K M) and aluminium.





Grade overview

B8

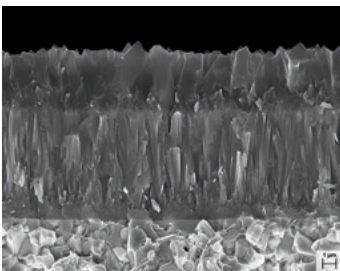

Grade designation	Standard designation		*Type of cutting material	Application range											P	M	K	N	S	H									
	ISO	ANSI		01	05	10	15	20	25	30	35	40	45	50	Steel	Stainless	Cast iron	Non-ferrous metals	Heat-resistant	Hard materials									
CTCP230 BLACKSTAR™	HC-P30	C6	C																			●							
	HC-K25	C2	C																						●				
	HC-M25	-	C																					○					
CTPP235 SILVERSTAR™	HC-P35	C5	P																				●						
	HC-M30	-	P																					○					
CTPM240 SILVERSTAR™	HC-M40	-	P																					●					
	HC-P40	C5	P																				○						
CTCK215 BLACKSTAR™	HC-K15	C3	C																						●				
CTPK220 SILVERSTAR™	HC-K20	C2	P																						●				
CTWN215	HW-N15	C3	W																							●			
	HW-K15	C3	W																						●				
				01	05	10	15	20	25	30	35	40	45	50	● Main application						○ Extended application								

CTCP230 BLACKSTAR™	HC-P30 HC-K25 HC-M25	
	<p>Specification: Composition: Co 10.5%; mixed carbides 2.0%; WC balance Grain size: 1-2 μm Hardness: HV₃₀ 1400 Coating specification: CVD TiCN-Al₂O₃</p> <p>Recommended application: First choice for dry machining of steels at high cutting speeds.</p>	

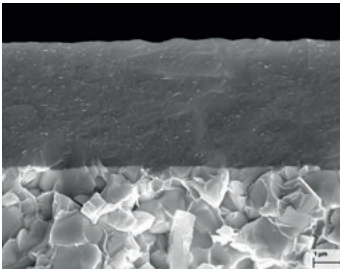
CTPP235 SILVERSTAR™	HC-P35 HC-M30	
	<p>Specification: Composition: Co 10.5%; mixed carbide 2.0%; WC balance Grain size: 1-2 μm Hardness: HV₃₀ 1400 Coating specification: PVD TiAlTaN</p> <p>Recommended application: Particularly suitable for the wet machining of steels.</p>	

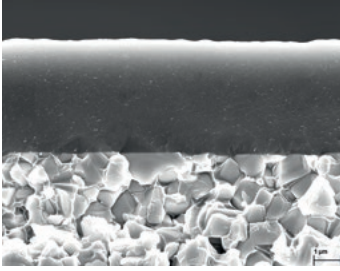
CTPM240 SILVERSTAR™	HC-M40 HC-P40	
	<p>Specification: Composition: Co 12.5%; mixed carbides 2.0%; WC balance Grain size: 1 μm Hardness: HV₃₀ 1380 Coating specification: PVD TiAlTaN</p> <p>Recommended application: The first choice for the machining of austenitic steels.</p>	

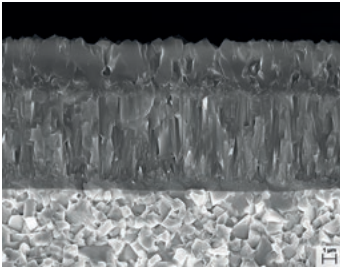

CTCK215 BLACKSTAR™	HC-K15	
	<p>Specification: Composition: Co 6.0%; mixed carbides 2.0%; WC balance Grain size: 1 μm Hardness: HV₃₀ 1630 Coating specification: CVD TiN; MT-TiCN; Al₂O₃</p> <p>Recommended application: The first choice for the machining of cast iron at high cutting speeds.</p>	

Grade description

B10

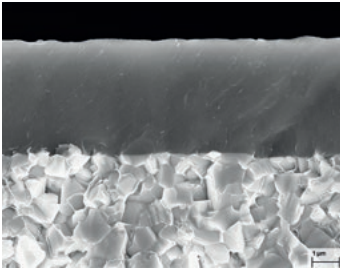

CTPK220 SILVERSTAR™	HC-K20	
	<p>Specification: Composition: Co 6.0%; mixed carbides 2.0%; WC balance Grain size: 1 µm Hardness: HV₃₀ 1630 Coating specification: PVD TiAlTaN</p> <p>Recommended application: Optimal for the machining of high-tensile cast iron materials when toughness is required.</p>	

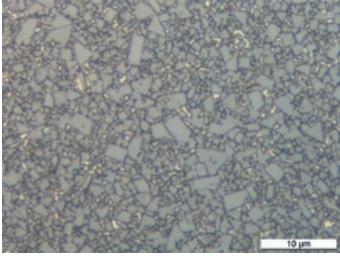
CTWN215	HW-N15 HW-K15	 
	<p>Specification: Composition: Co 6.0%; others 0.2%; WC balance Grain size: submicron Hardness: HV₃₀ 1650</p> <p>Recommended application: The uncoated carbide grade for the machining of aluminium and other non-ferrous metals.</p>	

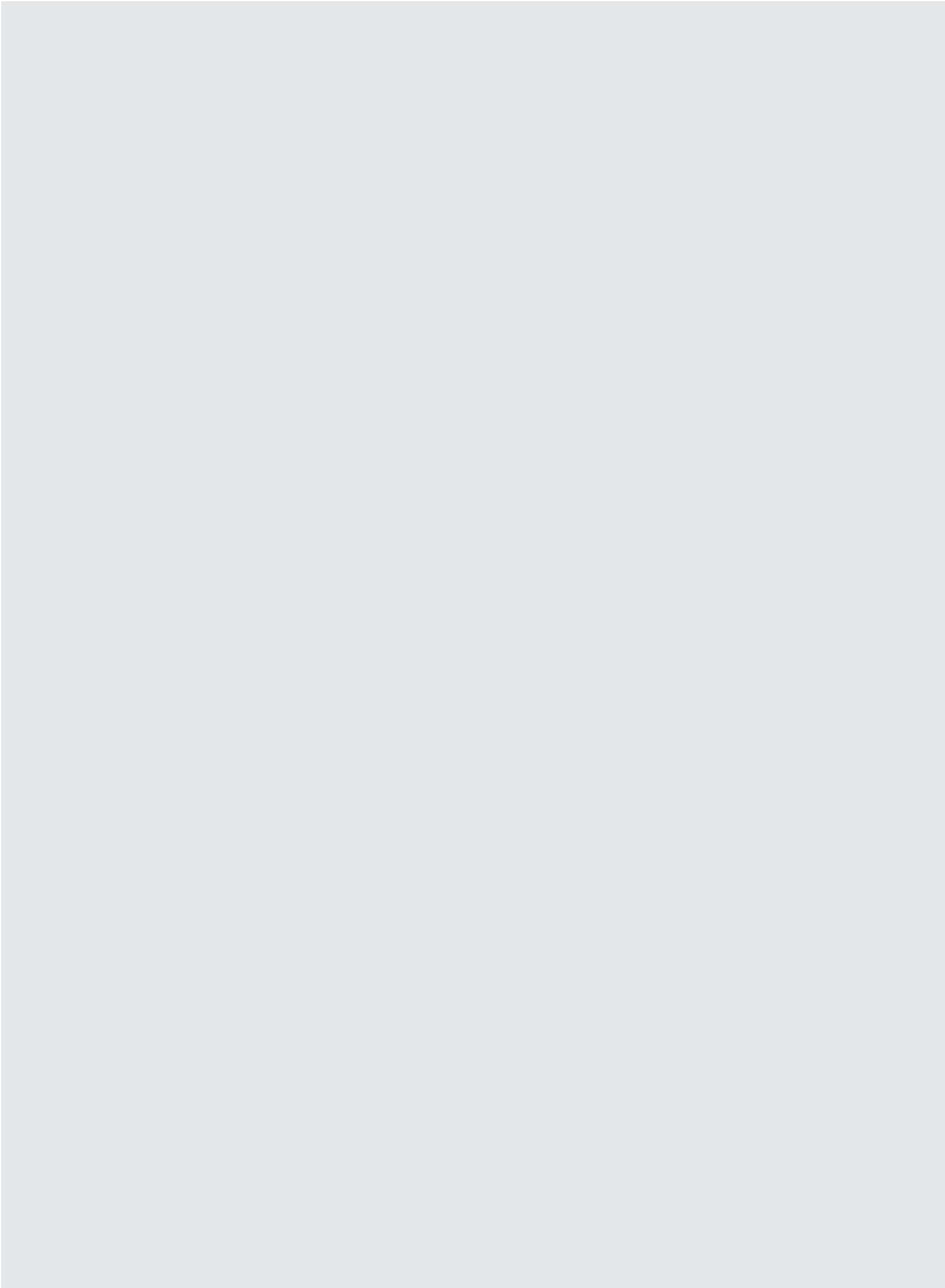



90° shoulder milling system with 8 cutting edges per insert

- Exact 90° profile
- Easy handling
- Ground precision insert with tolerance H

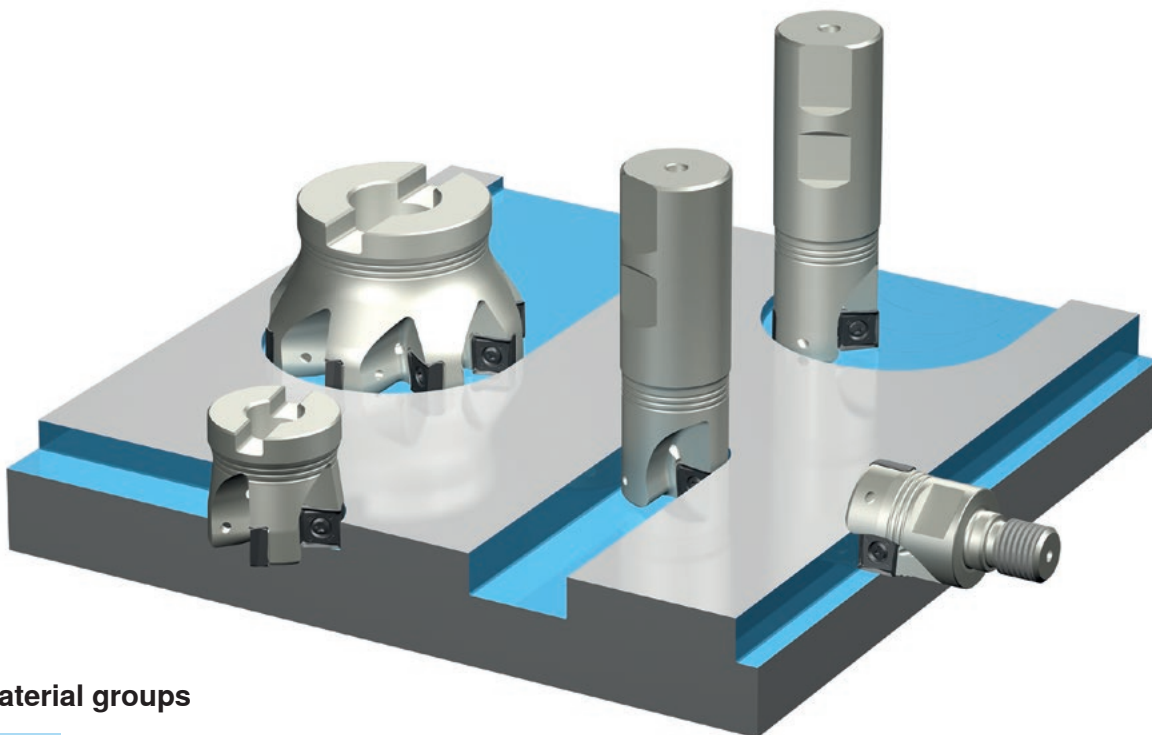

Material groups

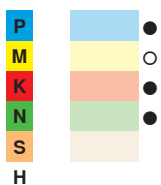

Possible applications

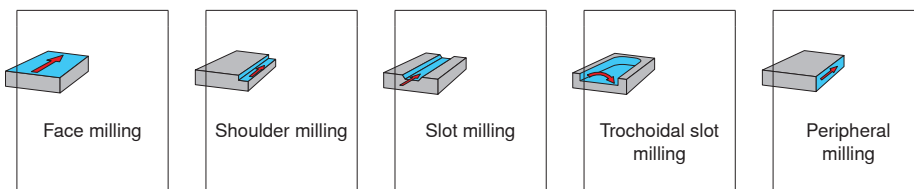



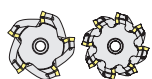

Detailed information



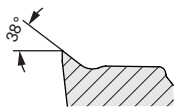

Pitch	Ø range	Inserts
	<p>Ø 32 - 160 mm</p>	<p>SNHU 12..</p>



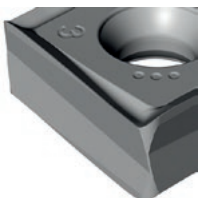
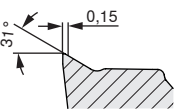

MaxiMill 491 system



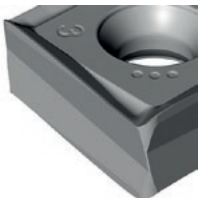
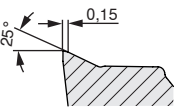

Geometry overview

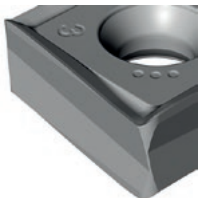
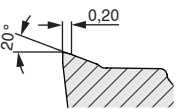

-F10 <ul style="list-style-type: none"> Highly positive geometry Sharp cutting edge Low tendency to adhesion First choice for non-ferrous metals 			Machining conditions		
					
			CTWN215		
		f_z [mm]	CTWN215	CTWN215	CTWN215
		0,05 - 0,25			

-F50 <ul style="list-style-type: none"> Positive geometry Finishing and roughing First choice for stainless steel materials 			Machining conditions		
					
			CTPM240	CTPM240	
		f_z [mm]			
		0,10 - 0,20			

-M50 <ul style="list-style-type: none"> Universal geometry Light to medium roughing operations First choice for general steel materials 			Machining conditions		
					
				CTCP230 CTPP235	CTCP230 CTPP235
				CTPM240	CTPM240
		f_z [mm]			
		0,10 - 0,25			



-R50 <ul style="list-style-type: none"> Stable geometry Roughing For heavily interrupted cut First choice for cast iron materials 			Machining conditions		
					
				CTCK215 CTPK220	CTCK215 CTPK220
		f_z [mm]			
		0,10 - 0,30			





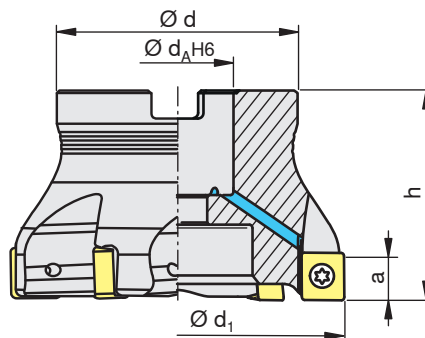
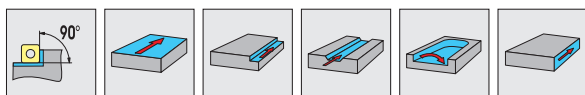

MaxiMill 491 system

A491-12

B15



d_1 [mm]	Type, description	h [mm]	d [mm]	d_A [mm]	a [mm]	z	n_{max} [min ⁻¹]	[Nm]			
40	A491.40.R.03-12	40	38	16	8	3	11500	3.2	SNHU 1204..		E01
40	A491.40.R.04-12	40	38	16	8	4	11500	3.2	SNHU 1204..		E01
50	A491.50.R.04-12	40	43	22	8	4	9800	3.2	SNHU 1204..		E02
50	A491.50.R.05-12	40	43	22	8	5	9800	3.2	SNHU 1204..		E02
63	A491.63.R.05-12	40	48	22	8	5	8500	3.2	SNHU 1204..		E02
63	A491.63.R.06-12	40	48	22	8	6	8500	3.2	SNHU 1204..		E02
80	A491.80.R.06-12	50	58	27	8	6	7400	3.2	SNHU 1204..		E02
80	A491.80.R.08-12	50	58	27	8	8	7400	3.2	SNHU 1204..		E02
100	A491.100.R.07-12	50	78	32	8	7	6500	3.2	SNHU 1204..		E02
100	A491.100.R.10-12	50	78	32	8	10	6500	3.2	SNHU 1204..		E02
125	A491.125.R.08-12	63	88	40	8	8	5700	3.2	SNHU 1204..		E02
125	A491.125.R.12-12	63	88	40	8	12	5700	3.2	SNHU 1204..		E02
160	A491.160.R.09-12	63	98	40	8	9	5000	3.2	SNHU 1204..		E02
160	A491.160.R.14-12	63	98	40	8	14	5000	3.2	SNHU 1204..		E02

					
E01	11036880	11610311	11450867	8095012000	4425
E02		11610311	11450867	8095012000	

MaxiMill 491 system

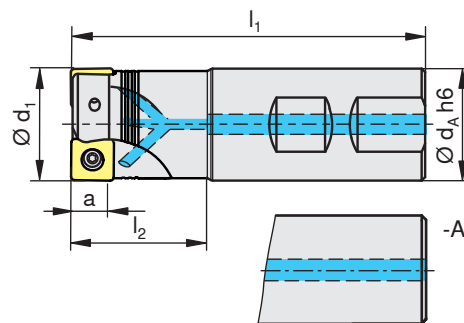
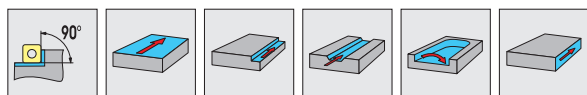

C491-12

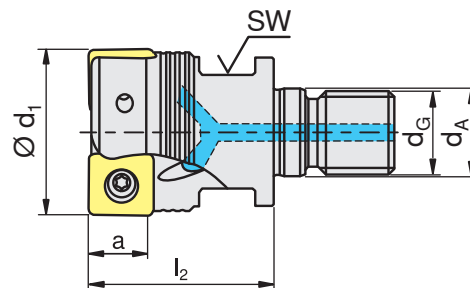
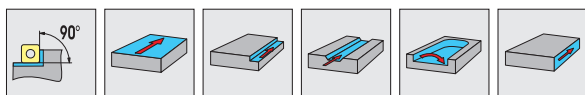

d_1 [mm]	Type, description	l_1 [mm]	l_2 [mm]	d_A [mm]	a [mm]	z	n_{max} [min ⁻¹]	[Nm]		
32	C491.32.R.02-12-A-63-250	250	63	32	8	2	10200	3.2	SNHU 1204..	E01
32	C491.32.R.02-12-B-40	102	40	32	8	2	13600	3.2	SNHU 1204..	E01

E01	11610311	11450867	8095012000



d_1 [mm]	Type, description	l_2 [mm]	d_G [mm]	d_A [mm]	a [mm]	z	n_{max} [min ⁻¹]	[Nm]		
32	G491.32.R.02-12	35	16	17.0	8	2	13600	3.2	SNHU 1204..	E01

			
E01	11610311	11450867	8095012000

MaxiMill 491 system

SNHU..

B18



	P	M	K	N	S	H						d	l	s	r	d ₁						
							CTCP230	CTPP235	CTPM240	CTCK215	CTPK220	CTWN215	[mm]	[mm]	[mm]	[mm]	[mm]					
-F10		●	○	○													12.20	12.20	5.00	0.80	4.40	
																		12.20	12.20	5.00	1.20	4.40
																		12.20	12.20	5.00	1.60	4.40
																		12.20	12.20	5.00	2.00	4.40
-F50																	12.20	12.20	5.00	0.80	4.40	
																	12.20	12.20	5.00	1.20	4.40	
																	12.20	12.20	5.00	1.60	4.40	
																	12.20	12.20	5.00	2.00	4.40	
-M50																	12.20	12.20	5.00	0.80	4.40	
																	12.20	12.20	5.00	1.20	4.40	
																	12.20	12.20	5.00	1.60	4.40	
																	12.20	12.20	5.00	2.00	4.40	
-R50																	12.20	12.20	5.00	0.80	4.40	
																	12.20	12.20	5.00	1.20	4.40	
																	12.20	12.20	5.00	1.60	4.40	
																	12.20	12.20	5.00	2.00	4.40	

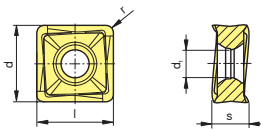



Milling / Shoulder milling

MaxiMill 491 system

Starting parameters for example materials



Materials				Insert		v_c [m/min]	Coolant
	1.2312	40CrMnMoS8-6	1.000 N/mm ²	SNHU 120408SR-M50	CTPP235	200	dry
	1.4571	X6CrNiMoTi17-12-2	600 N/mm ²	SNHU 120408SR-F50	CTPM240	140	dry
	5.1301	EN-GJL-250	HB 180	SNHU 120408SR-R50	CTCK215	250	dry
	3.4365	Alu	450 N/mm ²	SNHU 120408SR-F10	CTCK215	1500	Minimum quantity lubrication



If $a_e < 50\%$ use correction list



#R01#

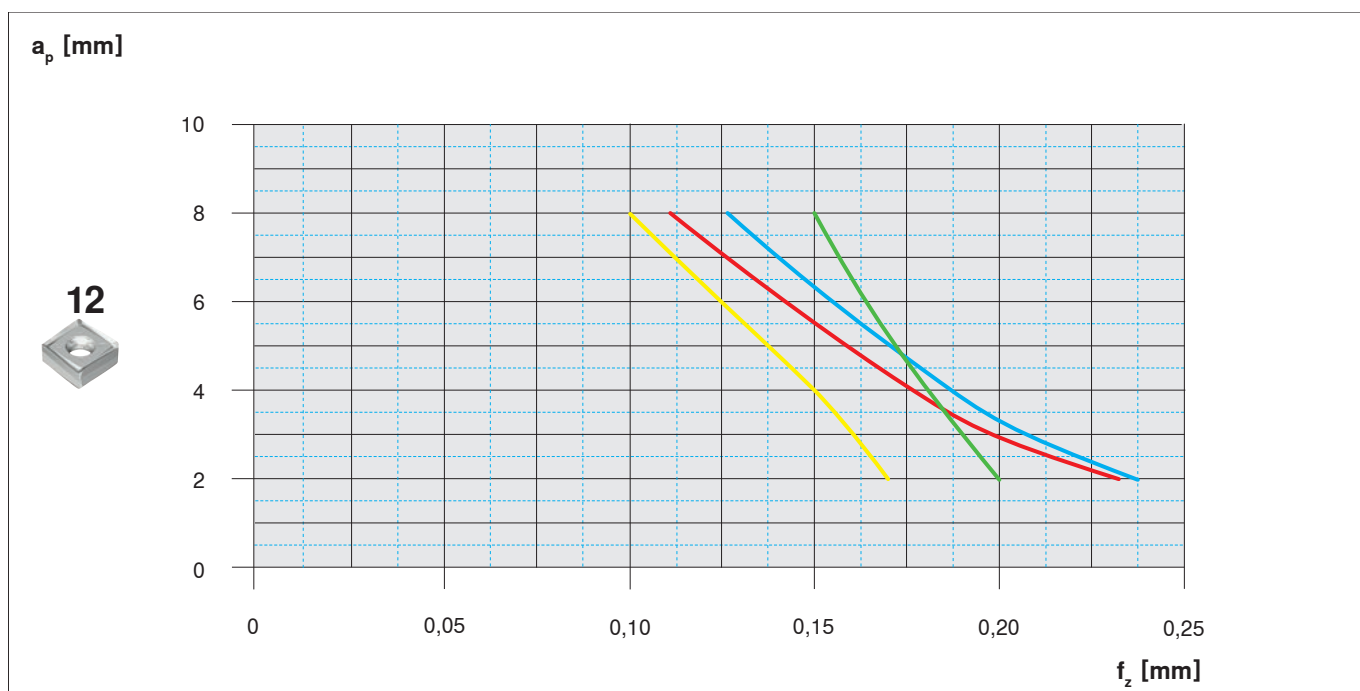

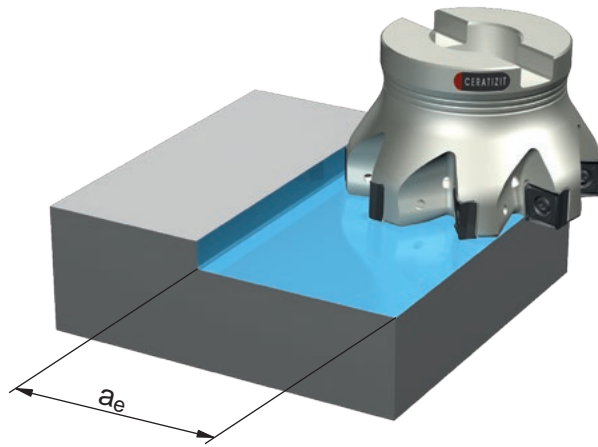

Starting values f_z [mm] from starting parameter diagram

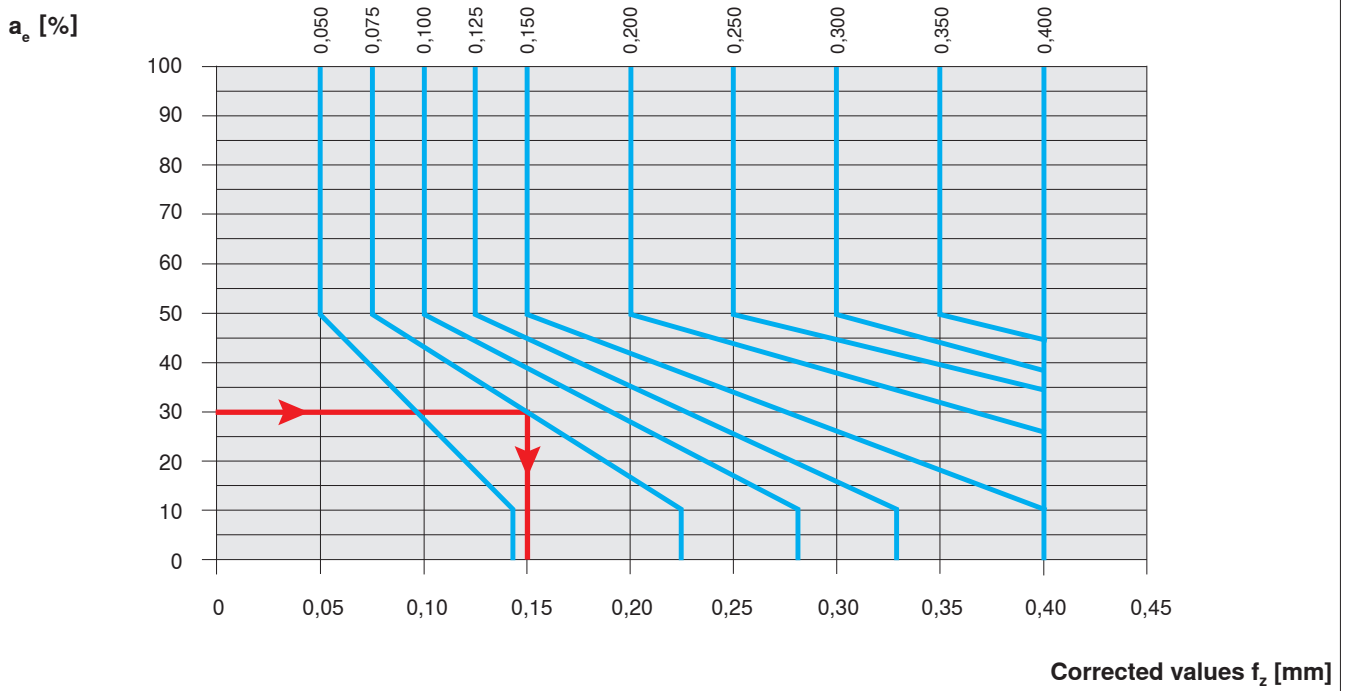

These parameters apply for cutting width (a_e) below 50%

Example:

Starting value [f_z] = 0.075 mm



a_e = 30%

Corrected value [f_z] = 0.15 mm



	Material	Type, description
	11036880	7818267/M8,0x30,0

	Material	Type, description	Key size	Torque moment [Nm]	Torque moment [in.lbs] [lb]
	11450867	DMSD 3,2Nm/SORT 15IP	IP15	3.2	28,3

	Material	Type, description	Key size
	8095012000	SD-T15IP-80mm	15IP
	4425	S4/SW4	SW4

	Material	Type, description	l [mm]	Thread size	Key size
	11610311	M3,5X8,6-15IP/10008749	8.6	M3,5	15IP

Cutting data

Grades, material

B24



	Work piece material	Type of treatment / alloy		VDI 3323 group	Hardness HB
P	Non alloyed steel	annealed	≤ 0.15 % C	1	125
		annealed	0.15 % - 0.45 % C	2	150 - 250
		tempered	≥ 0.45 % C	3	300
	Low alloyed steel	annealed		6	180
		tempered		7 / 8	250 - 300
		tempered		9	350
	High alloyed steel	annealed		10	200
		tempered		11	350
	Stainless steel	annealed	ferritic / martensitic	12	200
		tempered	martensitic	13	325
heat-treated		ferritic / martensitic	13	200	
M	Stainless steel	quenched	austenitic	14	180
		quenched	ferritic / austenitic (Duplex)	14	230 - 260
		hardened	austenitic, precipitation hardened (PH)	14	330
K	Grey cast iron		pearlitic / ferritic	15	180
			pearlitic / martensitic	16	260
	Spheroidal cast iron		ferritic	17	160
			pearlitic	18	250
	Malleable cast iron		ferritic	19	130
		pearlitic	20	230	
N	Aluminium wrought alloys	non hardened		21	60
		hardened		22	100
	Aluminium cast alloys	non hardened	< 12 % Si	23	75
		hardened	< 12 % Si	24	90
		non hardened	> 12 % Si	25	130
	Copper and copper alloys (bronze, brass)		machining alloy stock (1% Pb)	26	(110)
			brass, red bronze	27	90
			bronze	28	100
			lead-free copper and electrolytic copper	28	100
	Non-metallic materials		thermosetting plastics	29	-
		fibre-reinforced plastics	29	-	
		hard rubber	30	-	
S	Heat-resistant alloys	annealed	Fe-base	31	200
		hardened	Fe-base	32	280
		annealed	Ni or Co-base	33	250
		hardened	Ni or Co-base 30 - 58 HRC	34	(350)
		cast	Ni or Co-base 1500 - 2200 N/mm ²	35	(320)
	Titanium alloys		pure titanium	36	R _m 440*
		alpha + beta alloys	37	R _m 1050*	
H	Tempered steel	hardened and tempered		38	55 HRC
		hardened and tempered		39	60 HRC
	Chilled castings	cast		40	400
	Tempered cast iron	hardened and tempered		41	55 HRC

* R_m = ultimate tensile strength, measured in MPa

Cutting data

Grades, material

B26



	Work piece material	Type of treatment / alloy		VDI 3323 group	Hardness HB
P	Non alloyed steel	annealed	≤ 0.15 % C	1	125
		annealed	0.15 % - 0.45 % C	2	150 - 250
		tempered	≥ 0.45 % C	3	300
	Low alloyed steel	annealed		6	180
		tempered		7 / 8	250 - 300
		tempered		9	350
	High alloyed steel	annealed		10	200
		tempered		11	350
	Stainless steel	annealed	ferritic / martensitic	12	200
		tempered	martensitic	13	325
heat-treated		ferritic / martensitic	13	200	
M	Stainless steel	quenched	austenitic	14	180
		quenched	ferritic / austenitic (Duplex)	14	230 - 260
		hardened	austenitic, precipitation hardened (PH)	14	330
K	Grey cast iron		pearlitic / ferritic	15	180
			pearlitic / martensitic	16	260
	Spheroidal cast iron		ferritic	17	160
			pearlitic	18	250
	Malleable cast iron		ferritic	19	130
		pearlitic	20	230	
N	Aluminium wrought alloys	non hardened		21	60
		hardened		22	100
	Aluminium cast alloys	non hardened	< 12 % Si	23	75
		hardened	< 12 % Si	24	90
		non hardened	> 12 % Si	25	130
	Copper and copper alloys (bronze, brass)		machining alloy stock (1% Pb)	26	(110)
			brass, red bronze	27	90
			bronze	28	100
			lead-free copper and electrolytic copper	28	100
	Non-metallic materials		thermosetting plastics	29	-
		fibre-reinforced plastics	29	-	
		hard rubber	30	-	
S	Heat-resistant alloys	annealed	Fe-base	31	200
		hardened	Fe-base	32	280
		annealed	Ni or Co-base	33	250
		hardened	Ni or Co-base 30 - 58 HRC	34	(350)
		cast	Ni or Co-base 1500 - 2200 N/mm ²	35	(320)
	Titanium alloys		pure titanium	36	R _m 440*
		alpha + beta alloys	37	R _m 1050*	
H	Tempered steel	hardened and tempered		38	55 HRC
		hardened and tempered		39	60 HRC
	Chilled castings	cast		40	400
	Tempered cast iron	hardened and tempered		41	55 HRC

* R_m = ultimate tensile strength, measured in MPa









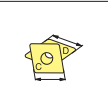

Introduction

	Revised product range	#R01#
---	-----------------------	-------

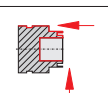
Index

	Index	#R01#
---	-------	-------

ProfileMaster

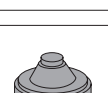
	System overview	#R01#
	Designation system	#R02#
	Chip grooves, grades	#R03#
	Machining methods	#R04#
	Inserts	#R05#
	Tools	#R06#
	Cutting data, feed rate	#R07#
	Surface quality	#R08#
	Application	#R09#
	Spare parts	#R10#
	Machining examples	#R11#

Multi-function tools

Revised product range

E4



ProfileMaster with a new guise

We have been consistently developing our ProfileMaster further - benefit from more than 20 years' experience with multi-function tools: the new 'Hard & Tough' coating protects the tool against abrasion and corrosion. Also new: the optimised double coolant supply ensures optimal chip evacuation and thus longer tool life. For improved stability, ProfileMaster also features a larger flange.

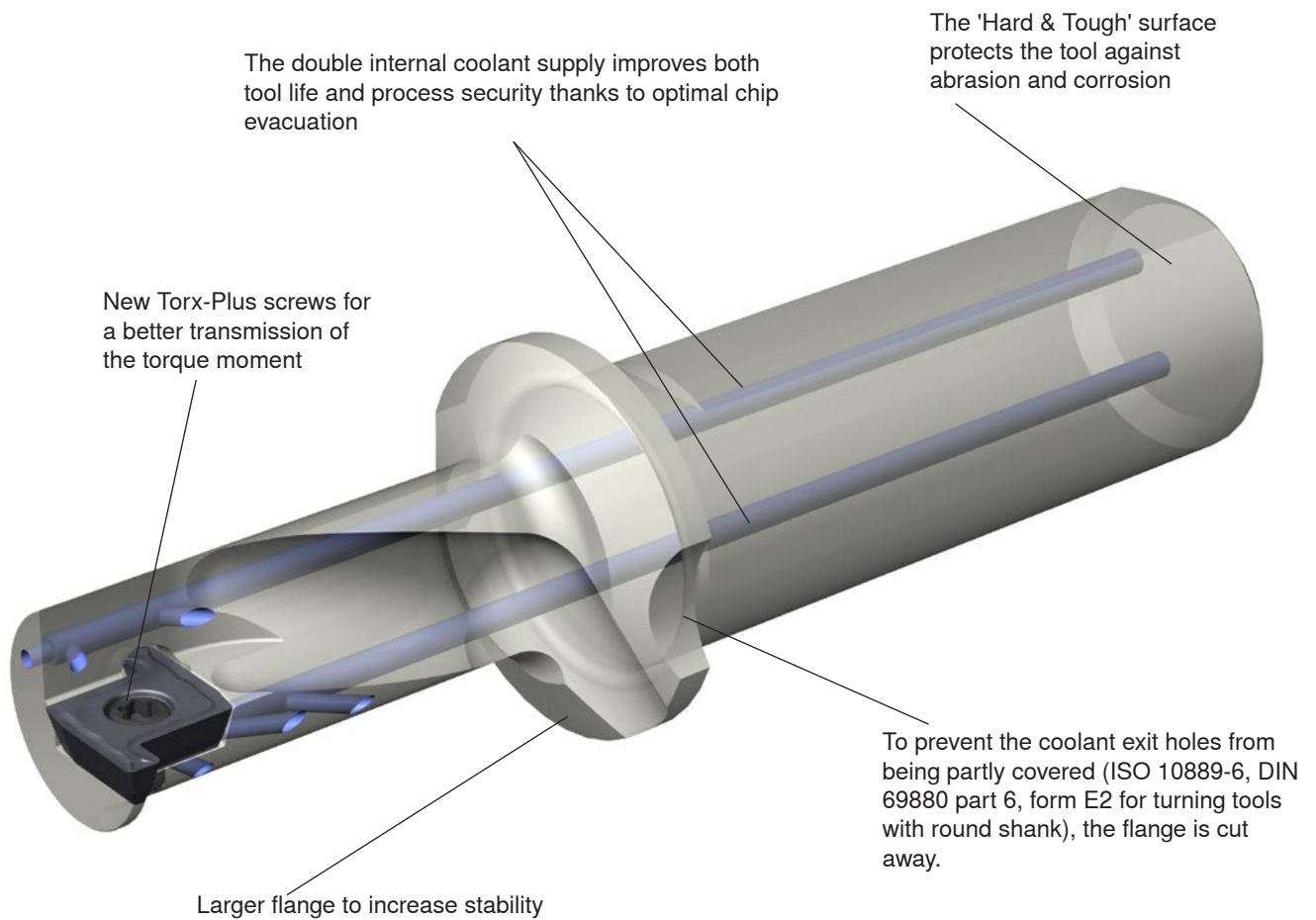
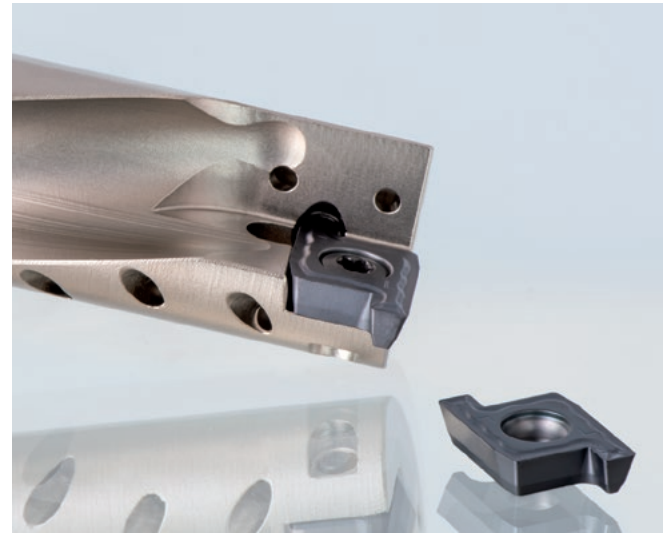

Your advantages

- ▲ Drilling, boring, face and longitudinal turning, counter-boring, off-centre drilling, axial or radial grooving
- ▲ Flat bottom holes
- ▲ Through coolant
- ▲ Easy to use

Your benefits

- ▲ One tool for several machining operations
- ▲ Fewer tool positions necessary
- ▲ Fewer tool changes
- ▲ Reduced machining time
- ▲ No additional tool required
- ▲ Good chip evacuation
- ▲ High process security
- ▲ Reduced pre-setting time
- ▲ Short set-up time
- ▲ Reduced programming effort

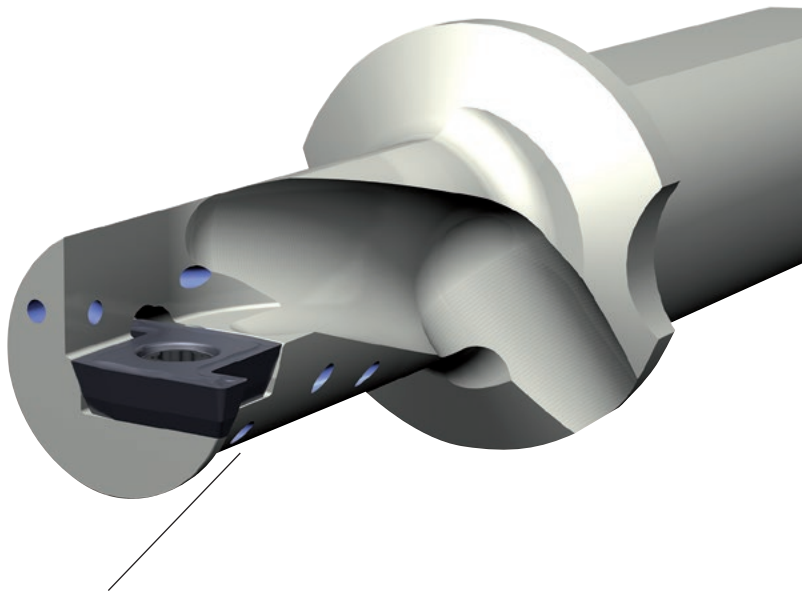

Due to the insert size the diameters 10 mm and 12 mm can be applied only as 90° version. For this reason the new tools are provided with a support in the area of the parting and grooving blade in the insert seat to increase stability.

SILVERSTAR™

SILVERSTAR™ CTPP430

The high-performance grade for steel materials, austenitic steel, cast iron materials and heat-resistant materials can be applied universally. Thanks to its high transverse rupture strength and cutting edge stability SILVERSTAR™ CTPP430 is ideal for applications with ProfileMaster.

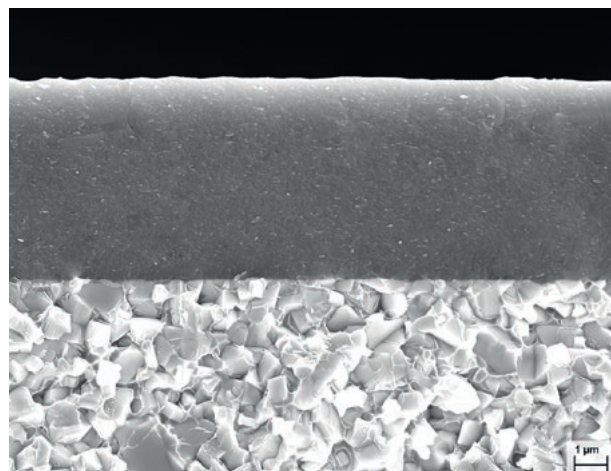



Drilling, turning, parting and grooving with only one tool

- The ProfileMaster is excellently suited for profiles that are so complex that they can normally only be produced with the use of several tools
- In addition, it helps free up valuable positions on the machine and minimise the need to change tools
- Thanks to the Masterfinish effect, the ProfileMaster produces an excellent surface finish in the shortest possible time

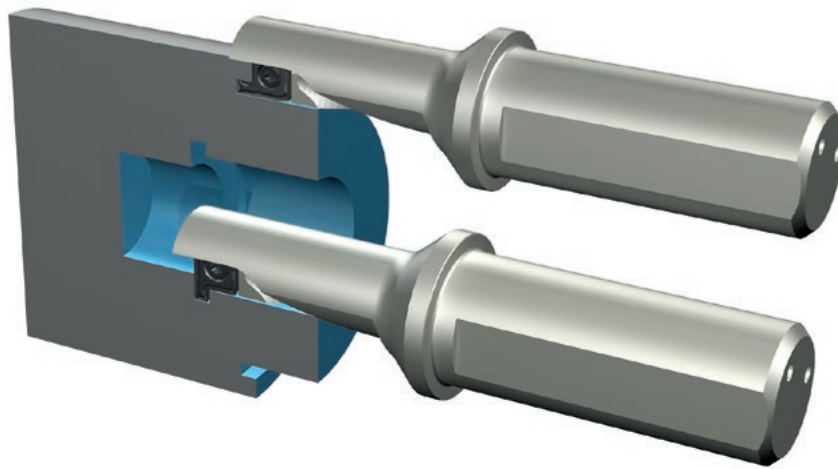

Material groups

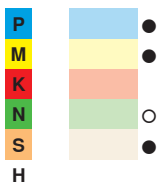

Possible applications

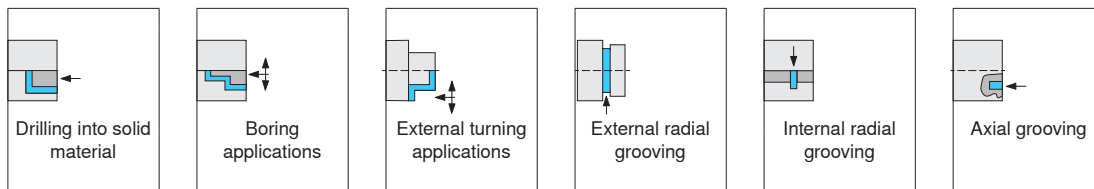

Detailed information

Diameter / length ratio	Ø range	Inserts
1,5 x D 2,25 x D	Ø 10 - 32 mm	PM 10.. .. PM 32..

CERATIZIT designation system

E8



Inserts

PM 25 R G 35 30 04 - M20







- 1** ProfileMaster
- 2** Nominal diameter [mm]
- 3** Cutting direction
- 4** Version
- 5** Parting and grooving width [$^{mm}/_{10}$]
- 6** Parting and grooving depth [$^{mm}/_{10}$]
- 7** Corner radius
- 8** Chip groove

Tools

PMC 25 R - 2.25D

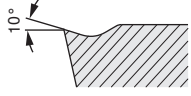

- 1** ProfileMaster
- 2** Nominal diameter [mm]
- 3** Cutting direction
- 4** Maximum drilling depth, for example: 3.0 x diameter

<p>-M20</p> <ul style="list-style-type: none"> o Positive geometry o Universal application o Small to medium feed rates 		Machining conditions		
				
		CTPP430	CTPP430	CTPP430
	f [mm]			
	0,05 - 0,25	CTPP430	CTPP430	CTPP430

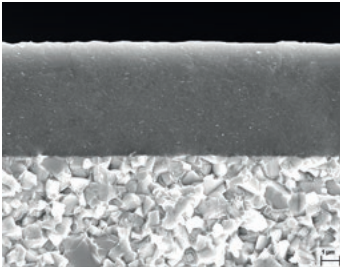
CTPP430	HC-P30 HC-M25 HC-S25 HC-K30 HC-N25	
	<p>Specification: Composition: Co 9.0%; others 0.75%; WC balance Grain size: 0.85 μm Hardness: HV₃₀ 1590 Coating specification: PVD TiAlN</p> <p>Recommended application: The universal high-performance grade for steel, austenitic steel and heat-resistant alloys.</p>	

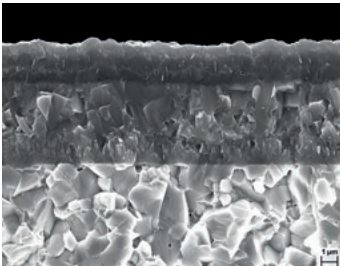
CTC1435	HC-P35 HC-M30 HC-K20	
	<p>Specification: Composition: Co 9.6%; mixed carbide 7.4%; WC balance Grain size: 1 - 2 μm Hardness: HV₃₀ 1400 Coating specification: CVD TiCN-Al₂O₃ multi-layer</p> <p>Recommended application: First choice for steel and cast iron materials.</p>	

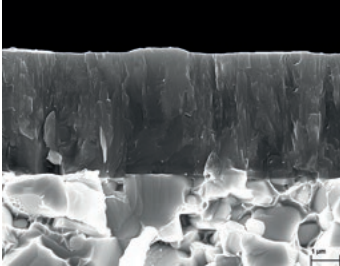
CTP2440	HC-M35 HC-P40 HC-N25 HC-S30	
	<p>Specification: Composition: Co 9.6%; mixed carbides 7.4%; WC balance Grain size: 1 - 2 μm Hardness: HV₃₀ 1400 Coating specification: PVD TiAlN</p> <p>Recommended application: First choice for stainless and steel materials under unstable conditions.</p>	

ProfileMaster

Machining methods

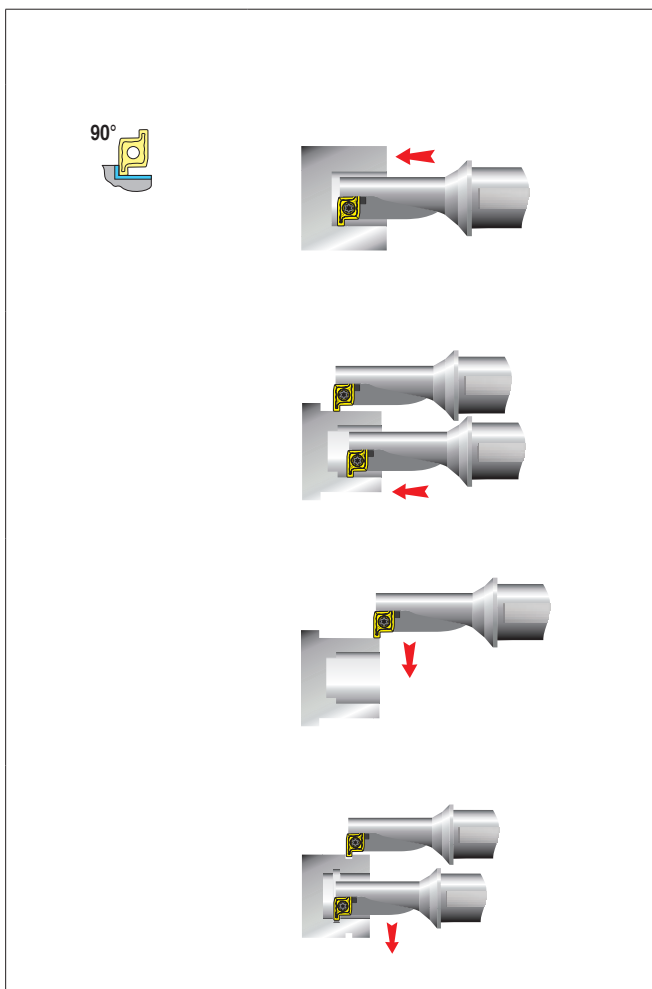

Machining methods - radial application 90°

Drilling into solid material with flat bottom holes

Boring applications

External turning applications

Internal turning applications

Turning of face profiles

External radial grooving

Internal radial grooving

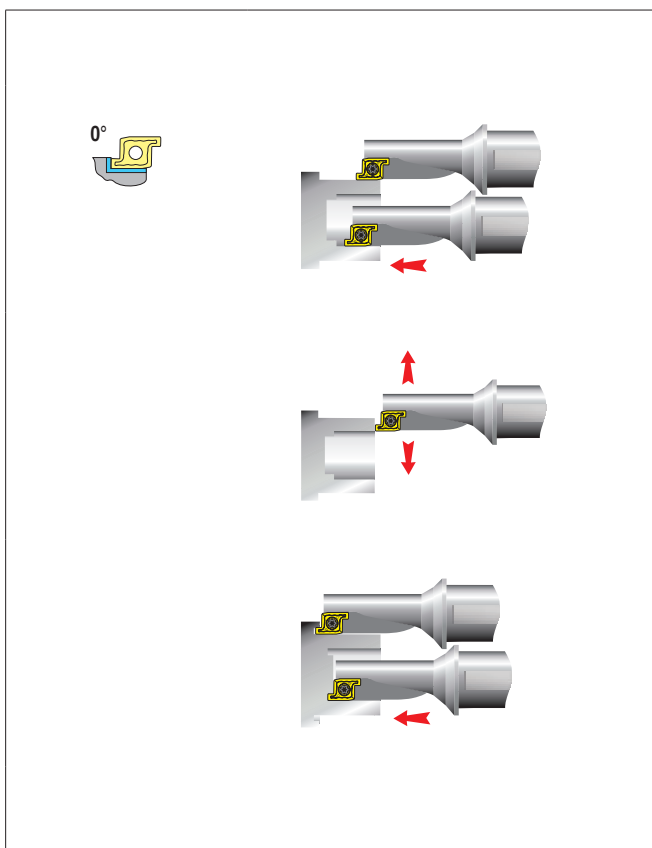

Machining methods - radial application 0°

External turning applications

Boring applications

Turning of face profiles

External radial grooving

Internal radial grooving



When changing from internal to external machining, reverse direction of rotation



right-hand tool

● right-hand insert



right-hand tool

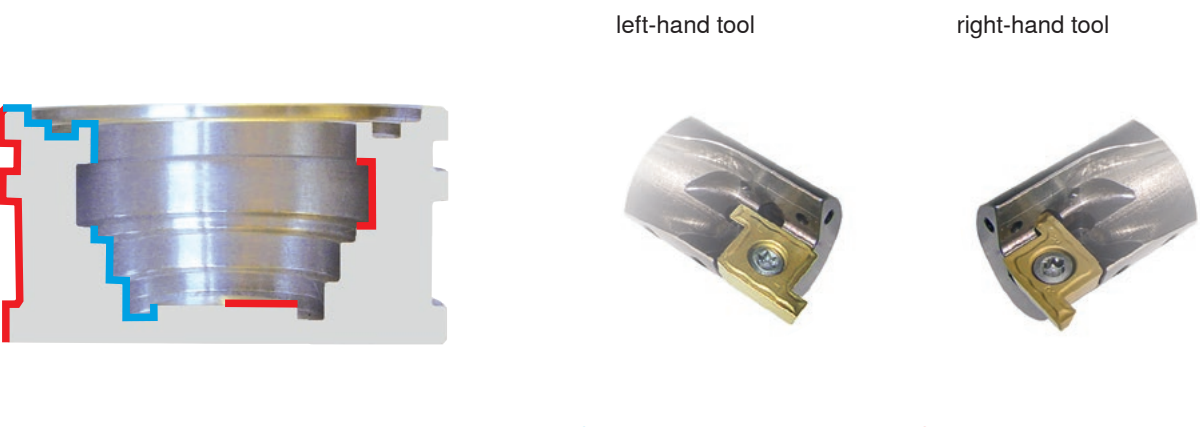

● left-hand insert ● right-hand insert





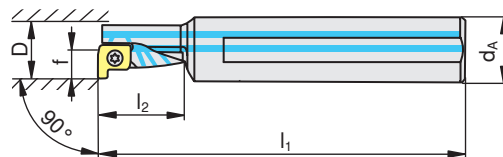
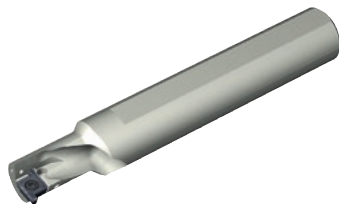
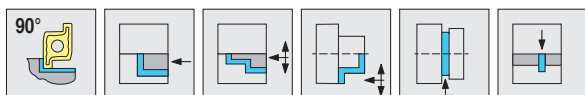

left-hand tool right-hand tool

● right-hand insert ● right-hand insert



D _{min} [mm]	Type, description	L N R 								
			d _A [mm]	l ₁ [mm]	l ₂ [mm]	f [mm]	[Nm]			
10	PMC 10R-1.5D	R	12	80	15	5	0.4	PM 10..	E01	
10	PMC 10L-1.5D	L	12	80	15	5	0.4	PM 10..	E01	
12	PMC 12R-1.5D	R	16	90	18	6	1.0	PM 12..	E02	
12	PMC 12L-1.5D	L	16	90	18	6	1.0	PM 12..	E02	
16	PMC 16R-1.5D	R	20	125	24	8	2.2	PM 16..	E03	
16	PMC 16L-1.5D	L	20	125	24	8	2.2	PM 16..	E03	
20	PMC 20R-1.5D	R	25	150	30	10	3.2	PM 20..	E04	
20	PMC 20L-1.5D	L	25	150	30	10	3.2	PM 20..	E04	
25	PMC 25R-1.5D	R	32	180	38	12.5	3.2	PM 25..	E05	
25	PMC 25L-1.5D	L	32	180	38	12.5	3.2	PM 25..	E05	
32	PMC 32R-1.5D	R	40	180	48	16	5.0	PM 32..	E06	
32	PMC 32L-1.5D	L	40	180	48	16	5.0	PM 32..	E06	

			
E01	11807484		11843205
E02	11450028		11488748
E03	12052220		11843208
E04	12052231	8095012000	
E05	11610311	8095012000	
E06	12052233	8095012100	

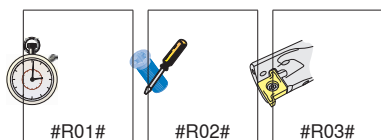

ProfileMaster

90° / 2.25D

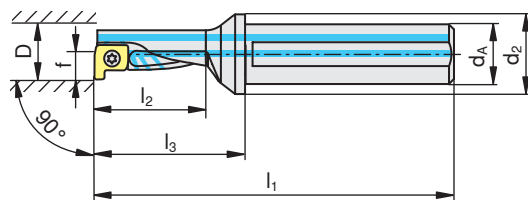
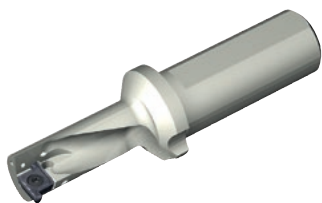
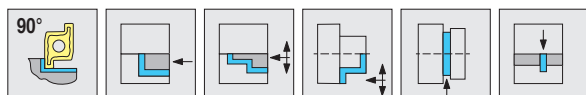



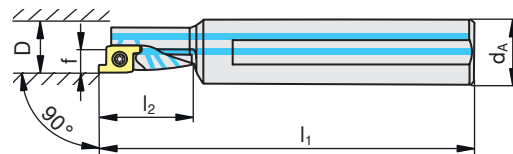
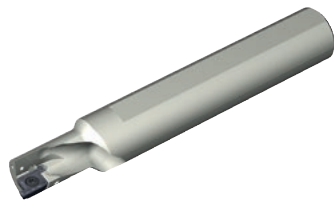
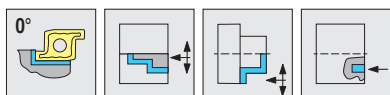

D _{min} [mm]	Type, description	LNR 										
			d _A [mm]	d ₂ [mm]	l ₁ [mm]	l ₂ [mm]	l ₃ [mm]	f [mm]	[Nm]			
10	PMC 10R-2.25D	R	12	18	72.4	22.5	30.4	5	0.4	PM 10..	E01	
10	PMC 10L-2.25D	L	12	18	72.4	22.5	30.4	5	0.4	PM 10..	E01	
12	PMC 12R-2.25D	R	16	22	78	27	33.0	6	1.0	PM 12..	E02	
12	PMC 12L-2.25D	L	16	22	78	27	33.0	6	1.0	PM 12..	E02	
16	PMC 16R-2.25D	R	20	28	96.5	36	46.5	8	2.2	PM 16..	E03	
16	PMC 16L-2.25D	L	20	28	96.5	36	46.5	8	2.2	PM 16..	E03	
20	PMC 20R-2.25D	R	25	35	111	45	55.0	10	3.2	PM 20..	E04	
20	PMC 20L-2.25D	L	25	35	111	45	55.0	10	3.2	PM 20..	E04	
25	PMC 25R-2.25D	R	32	44	132.6	56.3	72.6	12.5	3.2	PM 25..	E05	
25	PMC 25L-2.25D	L	32	44	132.6	56.3	72.6	12.5	3.2	PM 25..	E05	
32	PMC 32R-2.25D	R	40	54	158	72	88.0	16	5.0	PM 32..	E06	
32	PMC 32L-2.25D	L	40	54	158	72	88.0	16	5.0	PM 32..	E06	

E01	11807484		11843205
E02	11450028		11488748
E03	12052220		11843208
E04	12052231	8095012000	
E05	11610311	8095012000	
E06	12052233	8095012100	

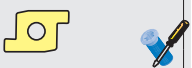



D _{min} [mm]	Type, description	L N R 	d _A [mm]	l ₁ [mm]	l ₂ [mm]	f [mm]	[Nm]		
16	PMC 16R-1.5D	R	20	127.2	26.2	5.75	2.2	PM 16..	E01
16	PMC 16L-1.5D	L	20	127.2	26.2	5.75	2.2	PM 16..	E01
20	PMC 20R-1.5D	R	25	152.7	32.7	7.30	3.2	PM 20..	E02
20	PMC 20L-1.5D	L	25	152.7	32.7	7.30	3.2	PM 20..	E02
25	PMC 25R-1.5D	R	32	183.2	41.2	9.30	3.2	PM 25..	E03
25	PMC 25L-1.5D	L	32	183.2	41.2	9.30	3.2	PM 25..	E03
32	PMC 32R-1.5D	R	40	184.2	52.2	11.85	5.0	PM 32..	E04
32	PMC 32L-1.5D	L	40	184.2	52.2	11.85	5.0	PM 32..	E04

			
E01	12052220		11843208
E02	12052231	8095012000	
E03	11610311	8095012000	
E04	12052233	8095012100	

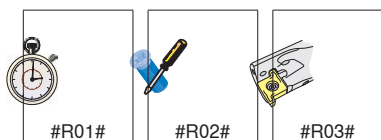

ProfileMaster

0° / 2.25D

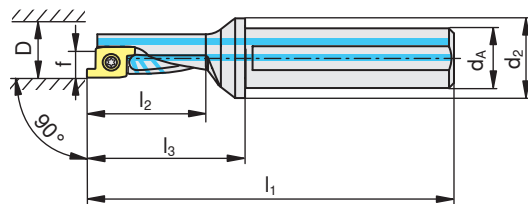
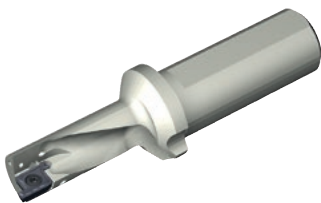
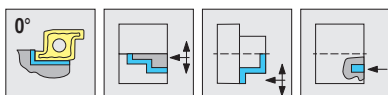

D _{min} [mm]	Type, description	LNR 										
			d _A [mm]	d ₂ [mm]	l ₁ [mm]	l ₂ [mm]	l ₃ [mm]	f [mm]	[Nm]			
16	PMC 16R-2.25D	R	20	28	98.7	38.2	48.7	5.75	2.2	PM 16..	E01	
16	PMC 16L-2.25D	L	20	28	98.7	38.2	48.7	5.75	2.2	PM 16..	E01	
20	PMC 20R-2.25D	R	25	35	113.7	47.7	57.7	7.30	3.2	PM 20..	E02	
20	PMC 20L-2.25D	L	25	35	113.7	47.7	57.7	7.30	3.2	PM 20..	E02	
25	PMC 25R-2.25D	R	32	44	135.8	59.5	75.8	9.30	3.2	PM 25..	E03	
25	PMC 25L-2.25D	L	32	44	135.8	59.5	75.8	9.30	3.2	PM 25..	E03	
32	PMC 32R-2.25D	R	40	54	162.2	76.2	92.2	11.85	5.0	PM 32..	E04	
32	PMC 32L-2.25D	L	40	54	162.2	76.2	92.2	11.85	5.0	PM 32..	E04	

E01	12052220			11843208
E02	12052231		8095012000	
E03	11610311		8095012000	
E04	12052233		8095012100	

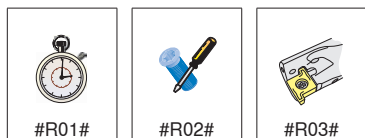



Cutting data

Grades, material

E20



	Work piece material	Type of treatment / alloy		VDI 3323 group	Hardness HB
P	Non alloyed steel	annealed	≤ 0.15 % C	1	125
		annealed	0.15 % - 0.45 % C	2	150 - 250
		tempered	≥ 0.45 % C	3	300
	Low alloyed steel	annealed		6	180
		tempered		7 / 8	250 - 300
		tempered		9	350
	High alloyed steel	annealed		10	200
		tempered		11	350
	Stainless steel	annealed	ferritic / martensitic	12	200
		tempered	martensitic	13	325
heat-treated		ferritic / martensitic	13	200	
M	Stainless steel	quenched	austenitic	14	180
		quenched	ferritic / austenitic (Duplex)	14	230 - 260
		hardened	austenitic, precipitation hardened (PH)	14	330
K	Grey cast iron		pearlitic / ferritic	15	180
			pearlitic / martensitic	16	260
	Spheroidal cast iron		ferritic	17	160
			pearlitic	18	250
	Malleable cast iron		ferritic	19	130
		pearlitic	20	230	
N	Aluminium wrought alloys	non hardened		21	60
		hardened		22	100
	Aluminium cast alloys	non hardened	< 12 % Si	23	75
		hardened	< 12 % Si	24	90
		non hardened	> 12 % Si	25	130
	Copper and copper alloys (bronze, brass)		machining alloy stock (1% Pb)	26	(110)
			brass, red bronze	27	90
			bronze	28	100
			lead-free copper and electrolytic copper	28	100
	Non-metallic materials		thermosetting plastics	29	-
		fibre-reinforced plastics	29	-	
		hard rubber	30	-	
S	Heat-resistant alloys	annealed	Fe-base	31	200
		hardened	Fe-base	32	280
		annealed	Ni or Co-base	33	250
		hardened	Ni or Co-base 30 - 58 HRC	34	(350)
		cast	Ni or Co-base 1500 - 2200 N/mm ²	35	(320)
	Titanium alloys		pure titanium	36	R _m 440*
			alpha + beta alloys	37	R _m 1050*
H	Tempered steel	hardened and tempered		38	55 HRC
		hardened and tempered		39	60 HRC
	Chilled castings	cast		40	400
	Tempered cast iron	hardened and tempered		41	55 HRC

* R_m = ultimate tensile strength, measured in MPa

CTPP430	CTC1435	CTP2440
v_c [m/min]	v_c [m/min]	v_c [m/min]
120 - 250	140 - 280	120 - 250
80 - 180	100 - 200	80 - 180
60 - 160	80 - 180	60 - 150
80 - 180	100 - 200	80 - 180
60 - 150	80 - 160	60 - 150
60 - 130	70 - 140	60 - 120
80 - 170	100 - 180	80 - 160
50 - 130	60 - 140	50 - 120
50 - 200	100 - 200	50 - 200
50 - 150	80 - 150	50 - 150
50 - 160	100 - 200	50 - 200
50 - 180	100 - 180	50 - 180
50 - 130		50 - 100
50 - 120		50 - 80
120 - 200	120 - 250	
100 - 180	120 - 250	
120 - 200	110 - 250	
100 - 180	110 - 250	
90 - 160	100 - 250	
70 - 150	100 - 250	
80 - 2000		100 - 500
80 - 1500		100 - 300
80 - 1500		100 - 500
80 - 1300		100 - 300
80 - 600		100 - 200
80 - 400		100 - 500
80 - 400		100 - 500
80 - 300		100 - 300
80 - 200		100 - 300
60 - 160		80 - 180
50 - 140		60 - 150
80 - 200		100 - 250
20 - 90		20 - 50
20 - 90		20 - 40
20 - 90		15 - 25
20 - 90		10 - 20
20 - 90		10 - 20
40 - 100		50 - 120
30 - 90		30 - 50

The cutting data are non-binding indications for the operator. It is recommended to adapt them to the current conditions.

ProfileMaster

90° depth of cut/feed rate



Drilling

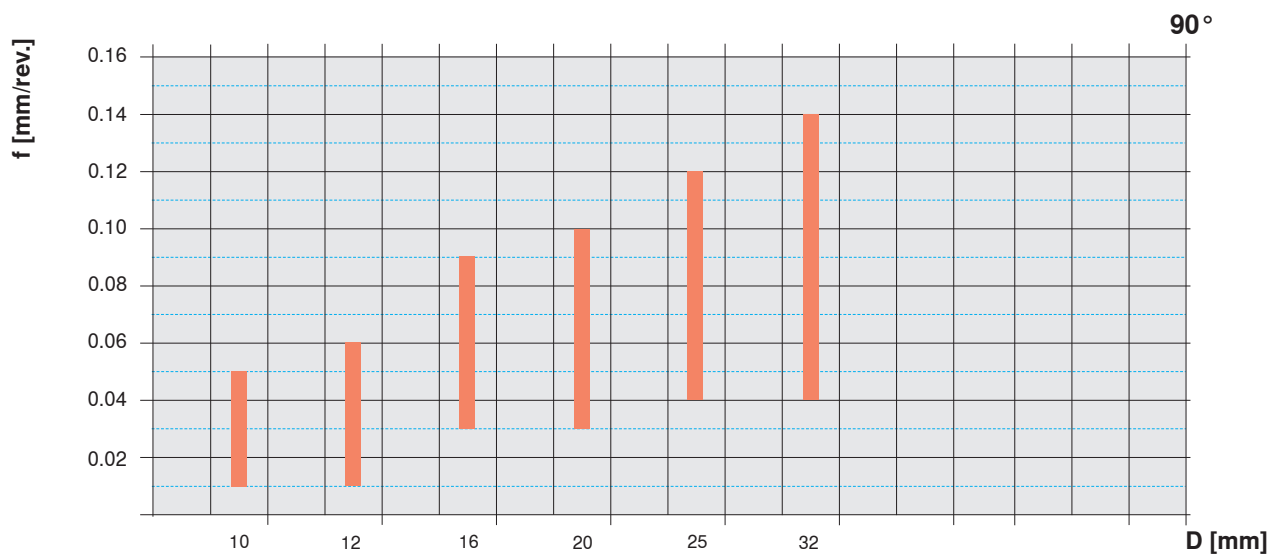
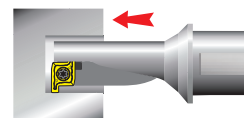

Face turning

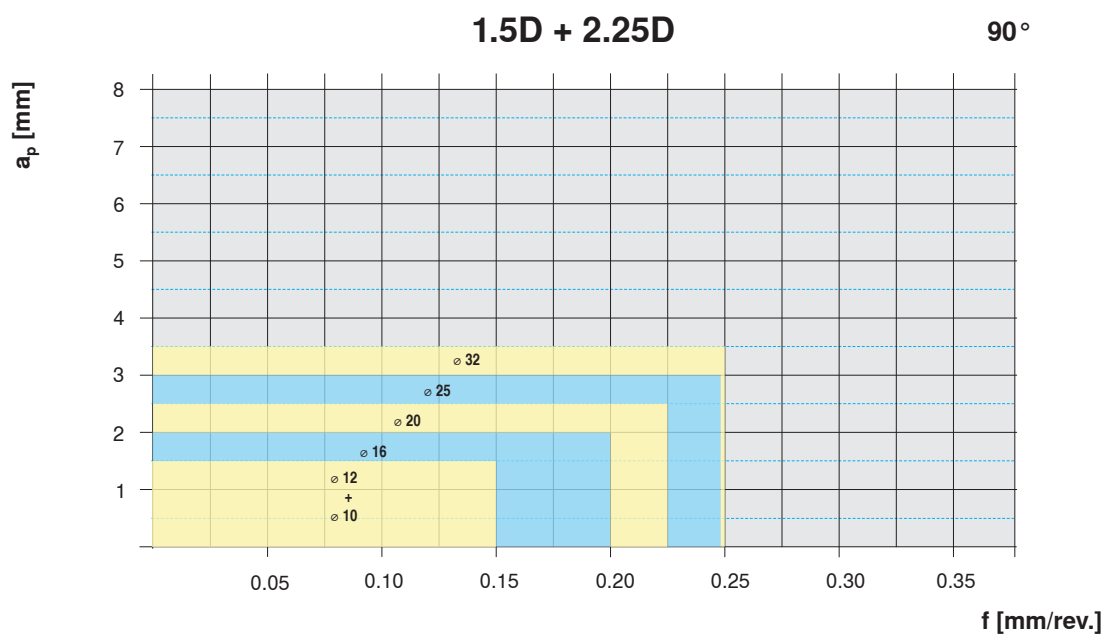
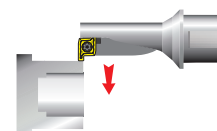

Longitudinal turning

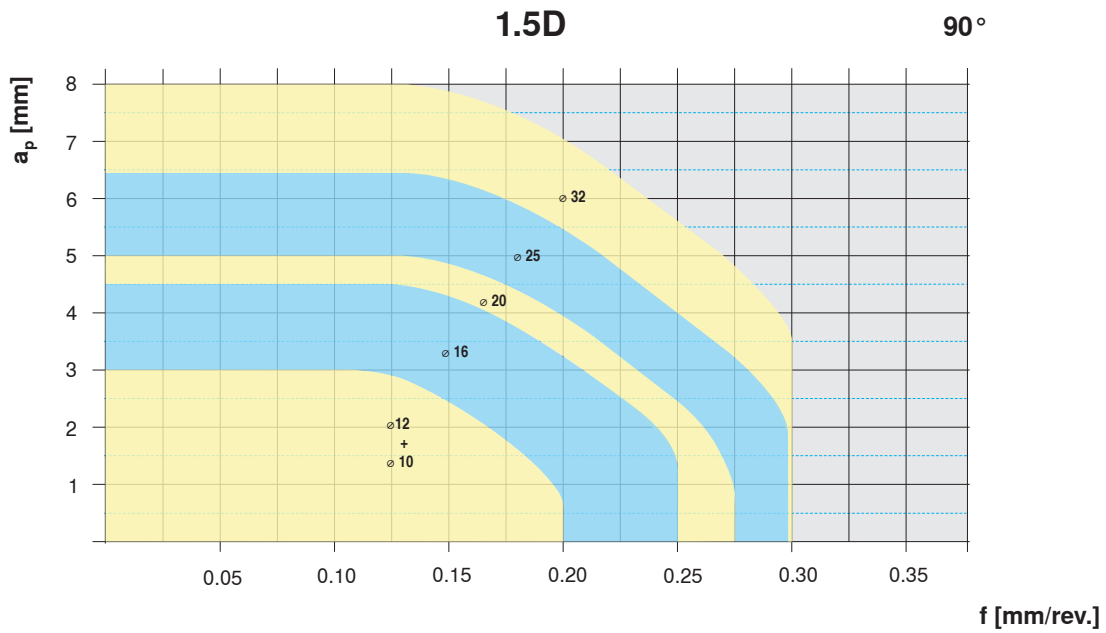
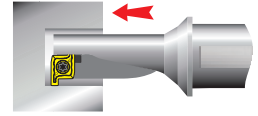

Longitudinal turning

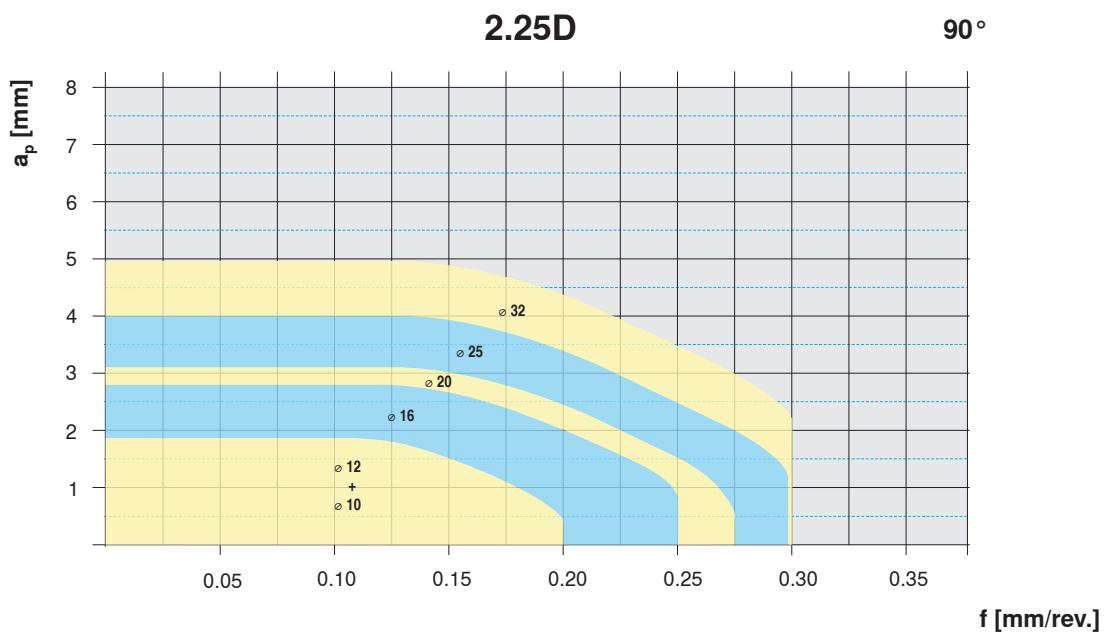
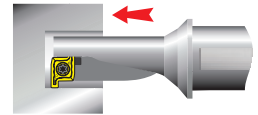

ProfileMaster

90° depth of cut/feed rate



Radial grooving - internal + external

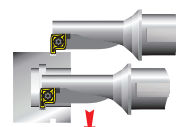

90°

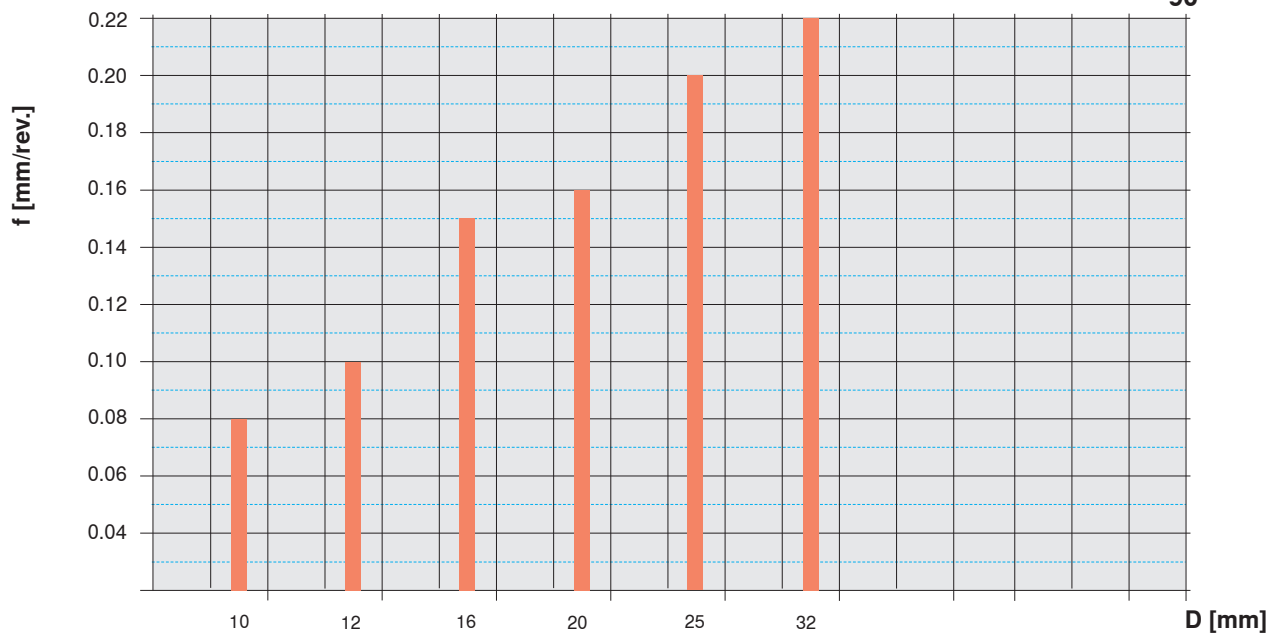

Longitudinal turning

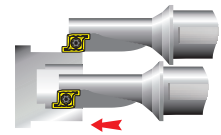

1.5D + 2.25D

0°

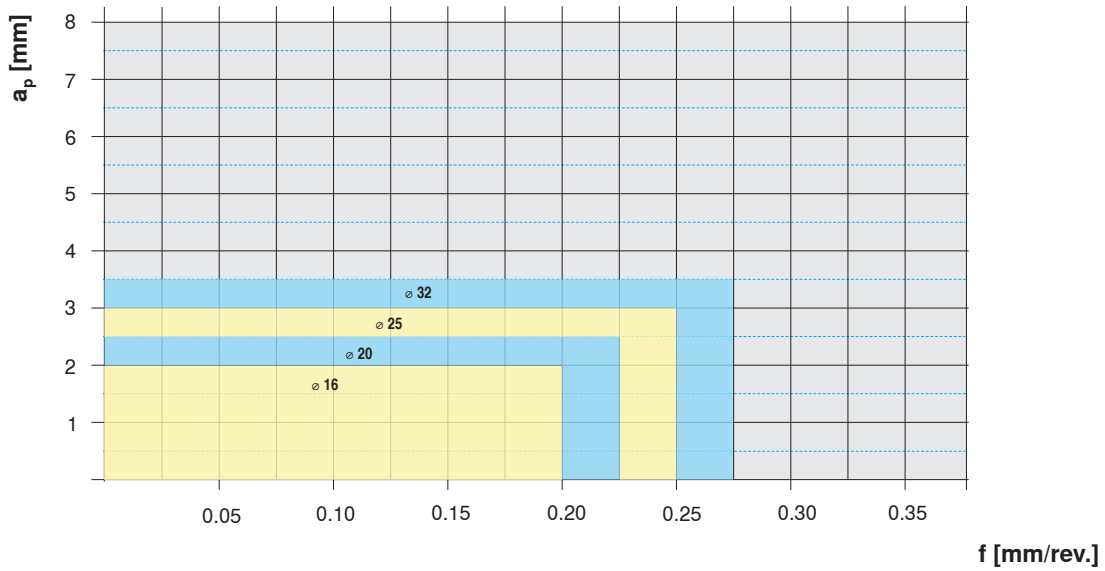

Face turning

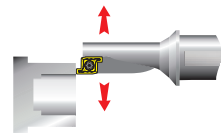

1.5D + 2.25D

0°

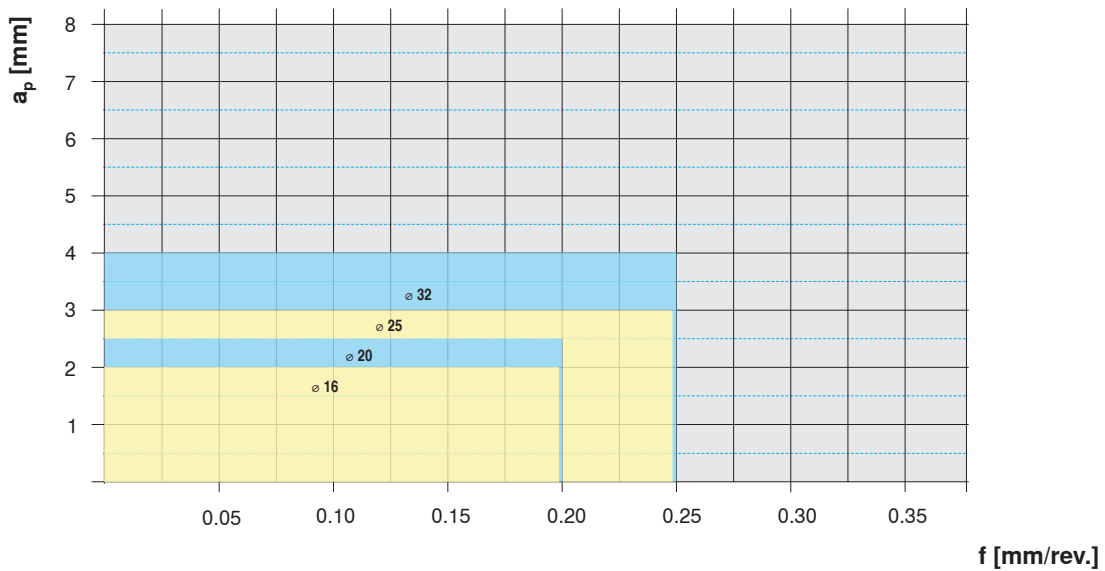

ProfileMaster

0° depth of cut/feed rate



Axial grooving - internal + external

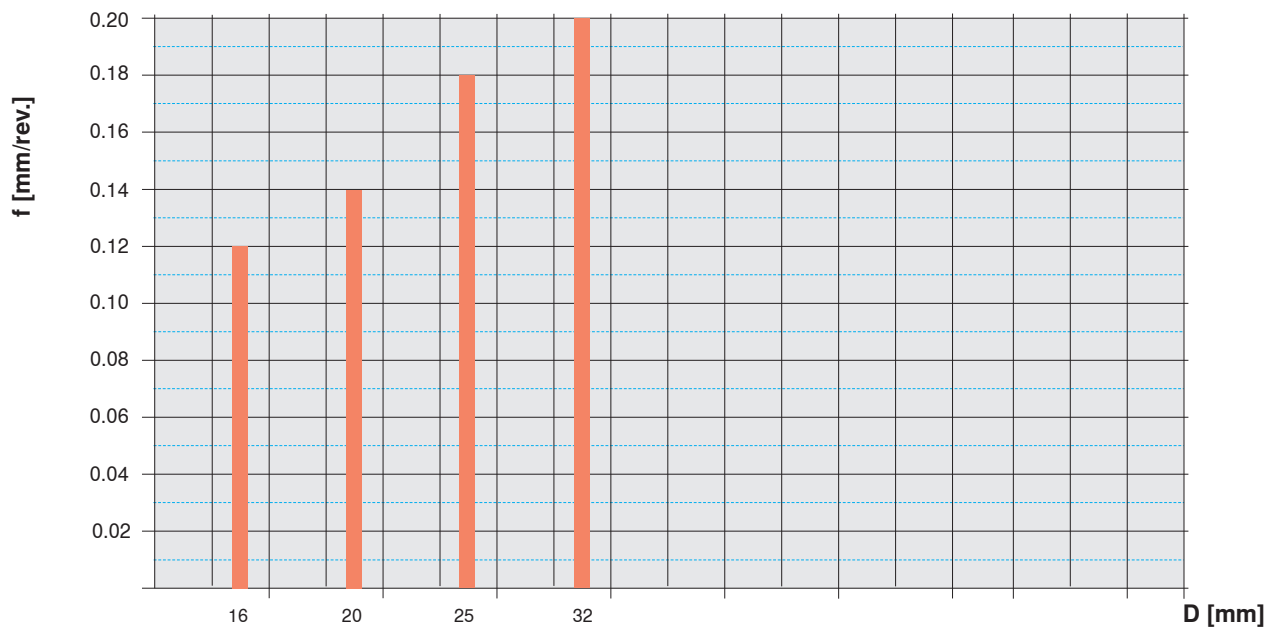
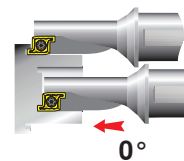

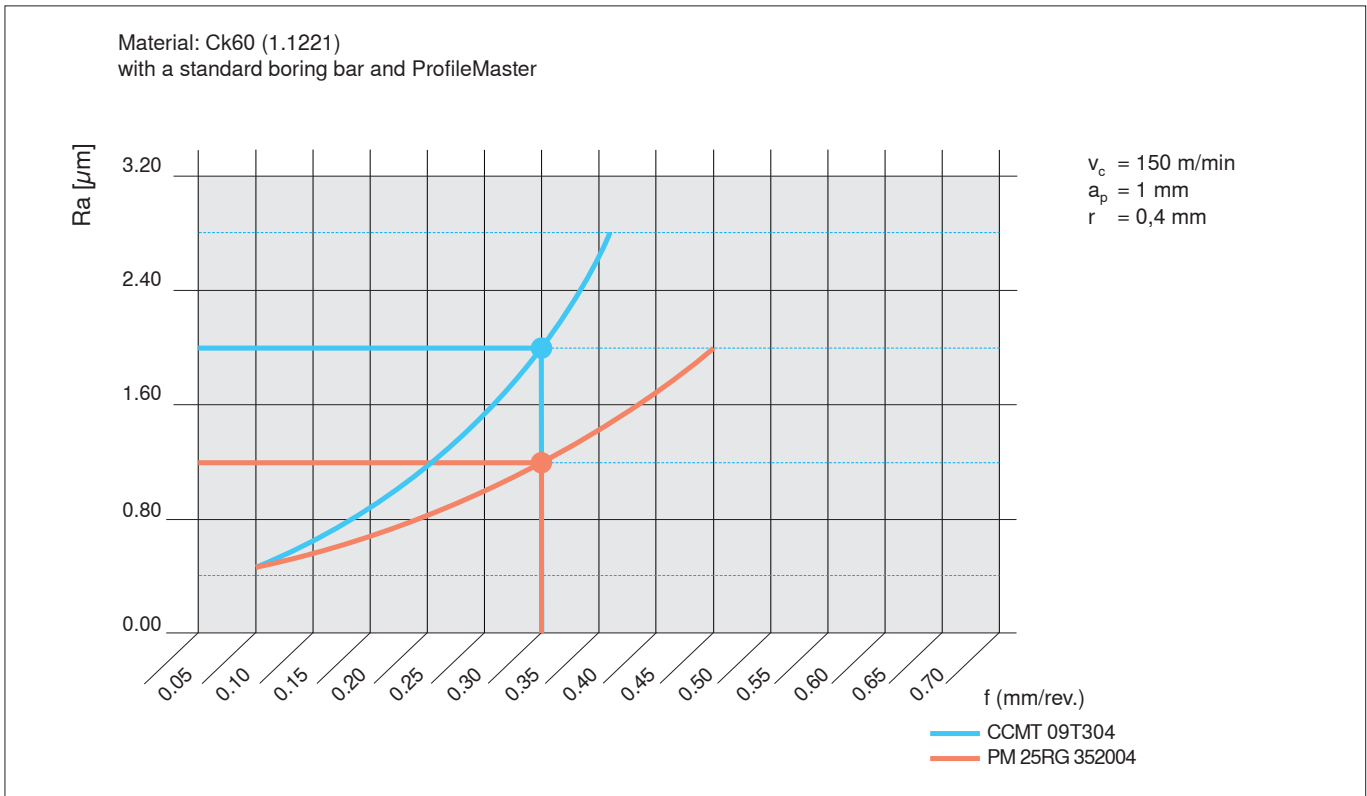

ProfileMaster

Problems, corrective measures



Type of problem								Corrective measures	
Type of wear				Work piece problems		Chip control			
Edge chipping	Built-up edge	Flank wear	Plastic deformation	Vibration	Surface quality	Chip too long (tangled swarf)	Chip too short (fragmented chip)		
	↑	↓	↓	↓ ↑	↓ ↑	↓		Cutting speed	Cutting values
↓		≈	↓	↓ ↑	↓	↑	↓	Feed rate	
↑		↑	↑	↓	↑			Corner radius	Selection of inserts
↓		↑	↑					Cutting material	
≈				≈	≈			Clamping of tool	General criteria
≈				≈	≈			Clamping of work piece	
≈				≈	≈			Overhang	
≈		≈		≈	≈			Tip height	
	○	○	○		○			Cooling lubricant	

↑ raise, increase, large influence

↓ avoid, reduce large influence

≈ check, optimise

↑ raise, increase low influence

↓ avoid, reduce low influence

○ use

ProfileMaster is equipped with a unique coolant and chip removal system.

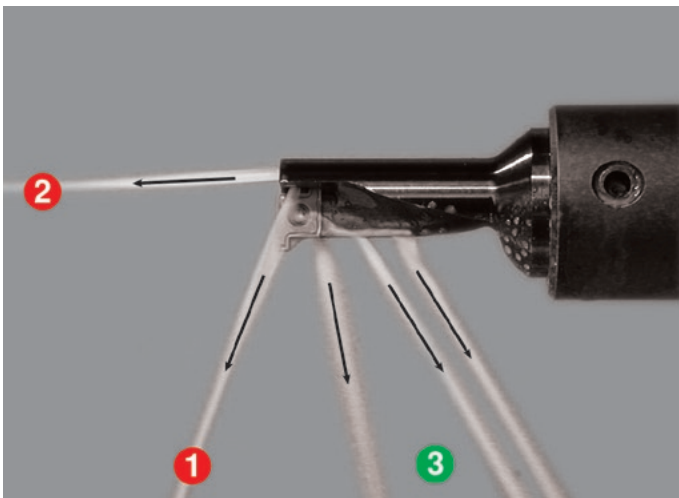

1

Cooling of the inserts

2

General coolant stream

3

Chipbooster prevents chips from getting stuck between tool and work piece



In order to guarantee efficient chip evacuation from a hole, a minimum coolant pressure of 3 - 6 bar (optimum 7 - 10 bar) is required.

ProfileMaster

Application

Mounting of the insert

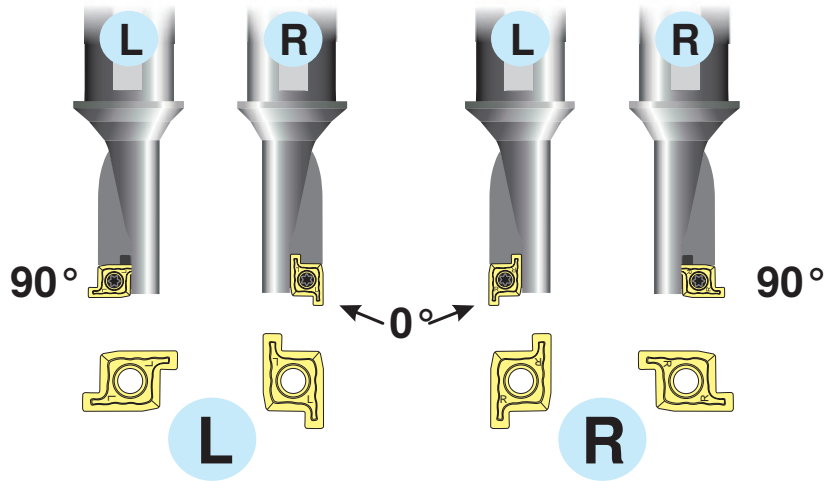

Axial displacement of the machine

Displacement in x-direction

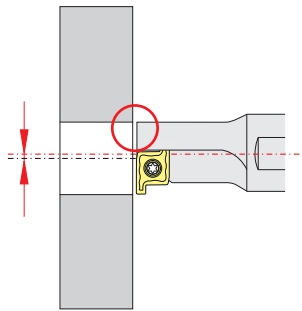

Angular error

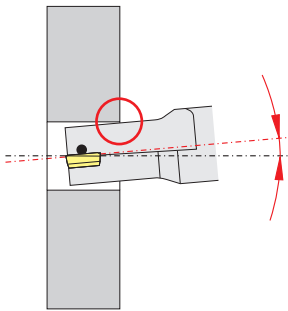

Turret position error

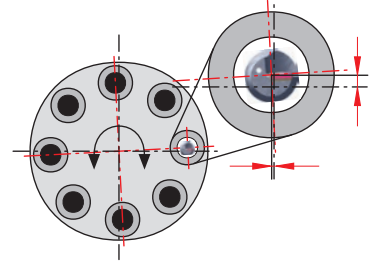

Through hole

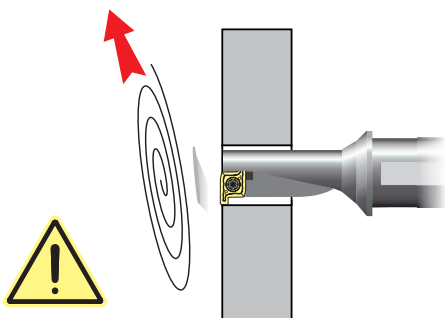

With through holes a **sharp-edged disk** as tool break-out occurs. Safety measures are necessary.

Off-centre drilling

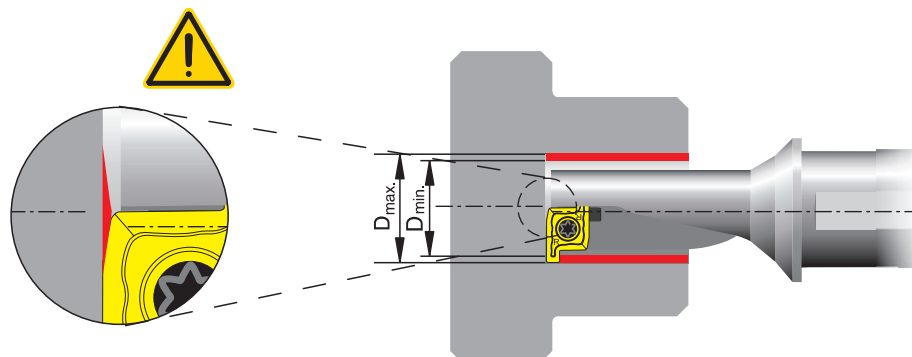

Due to the special construction of ProfileMaster tools and inserts off-centre drilling is possible. Thus desired deviations from the tool's nominal diameter can be obtained (see table below).

Type of tool	Nominal tool diameter	Drilling diameter (work piece)	
	D [mm]	D _{min} [mm]	D _{max} [mm]
PMC 10R/L ...	10	9,85	12
PMC 12R/L ...	12	11,85	15
PMC 16R/L ...	16	15,85	19
PMC 20R/L ...	20	19,80	24
PMC 25R/L ...	25	24,80	29
PMC 32R/L ...	32	31,80	38

Machining across centre line

Situation:

In case of insufficient movement of the machine across the centre line the external diameter can not be machined with the same tool.

Solution:

Use a right-hand ProfileMaster tool.

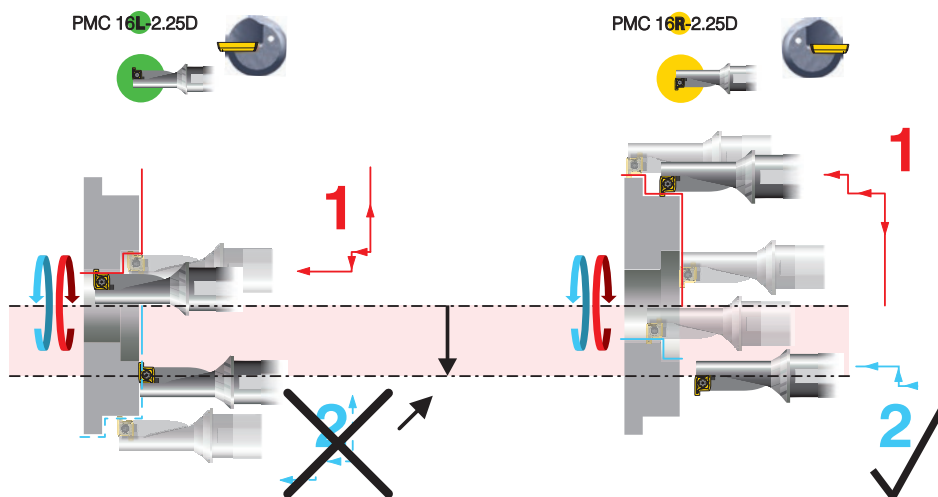

ProfileMaster

Axial grooving - application 0°

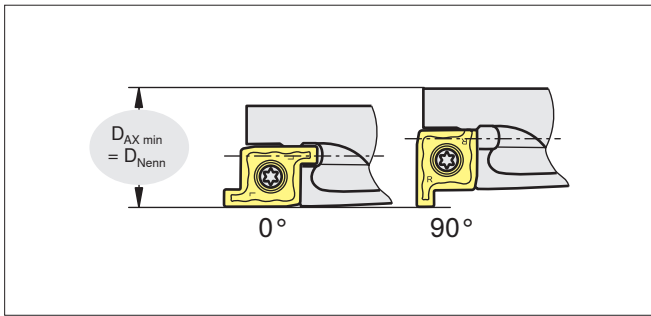

E32

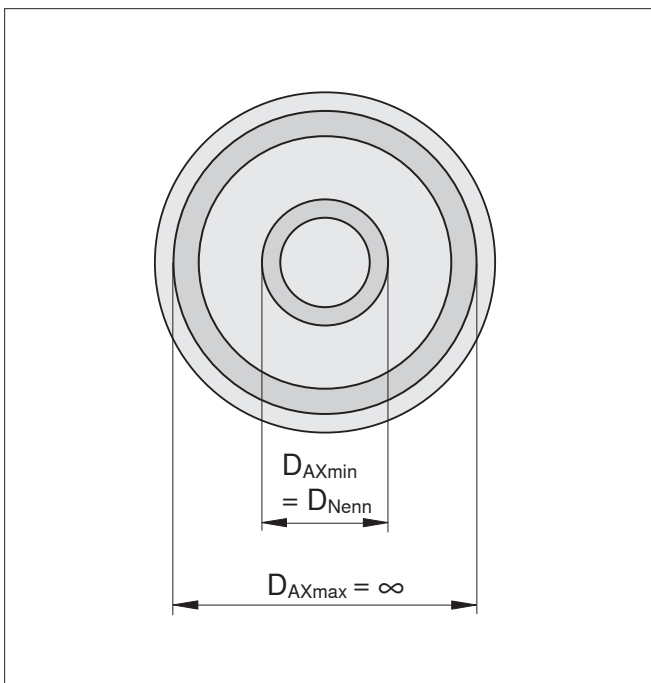
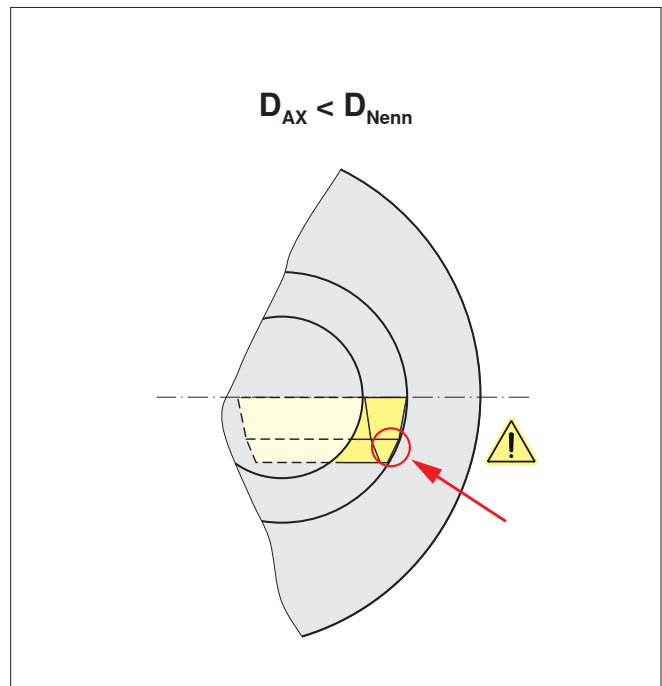
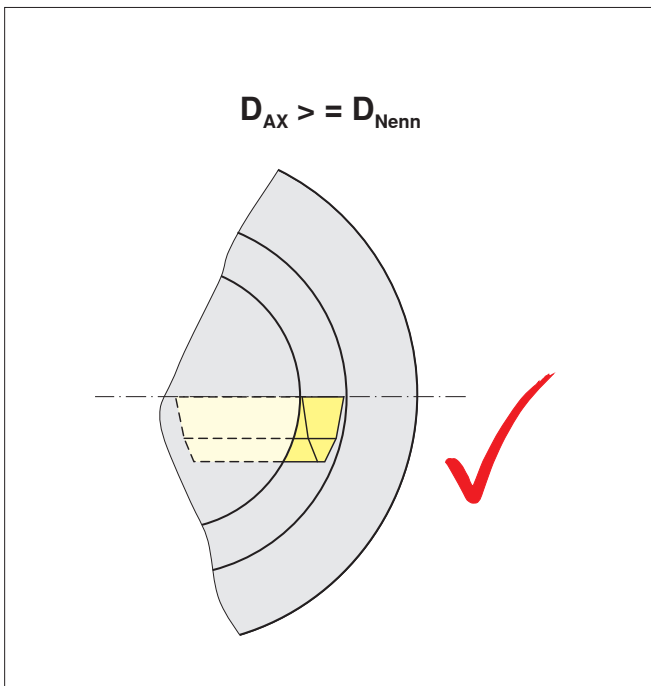

D_{Nenn}	D_{AXmin}	D_{AXmax}
16	16	∞
20	20	∞
25	25	∞
32	32	∞



If the first cut is carried out with a diameter which is smaller than the nominal tool diameter D_{Nenn} (90° application), collision will result.

	Material	Type, description	Key size
	11488748	10007404/TORX 07IP F	07IP
	11843205	10014921/TORX 06IP F	06IP
	11843208	10014922/TORX 09IP F	09IP
	8095012000	SD-T15IP-80mm	15IP
	8095012100	SD-T20IP-100mm	20IP

	Material	Type, description	l [mm]	Thread size	Key size
	11450028	M2,2X4,2-07IP/10006888	4.2	M2,2	07IP
	11610311	M3,5X8,6-15IP/10008749	8.6	M3,5	15IP
	11807484	M1,8x3,6-06IP/10013338	3.6	M1,8	06IP
	12052220	M3,0X5,7-09IP/10022515	5.7	M3,0	09IP
	12052231	M3,5X7,2-15IP/10022527	7.2	M3,5	15IP
	12052233	M5,0X10,8-20IP/10022539	10.8	M5,0	20IP

Machining example

E34

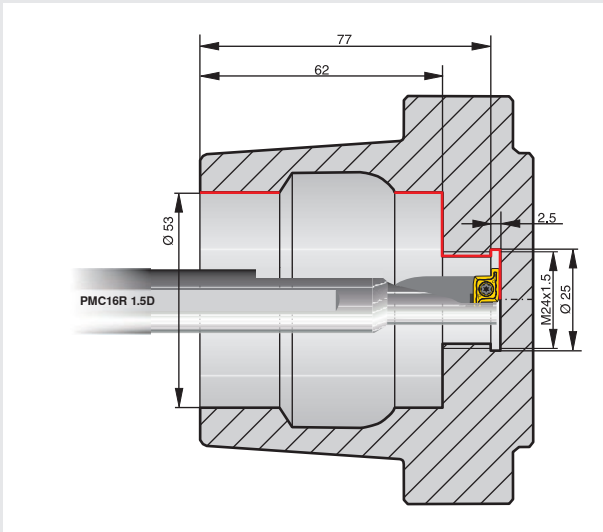

Technical data

Work piece	HSK100 adapter
Material	1.2342 X38 CrMoV 5 1
Tensile strength	approx. 1100 N/mm ²
Tool	PMC 16R-1.5D
Insert	PM 16RG 252004-M20 CTP2440
Competitor	2 tools

		CERATIZIT	
v _c	[m/min]	150	
f	[mm]	0.15	
a _p	[Ø mm]	1	

Criteria

- Problems due to lack of turret positions
- Optimisation of machining time

Result

- Only 1 tool instead of 2
- 1 free turret position

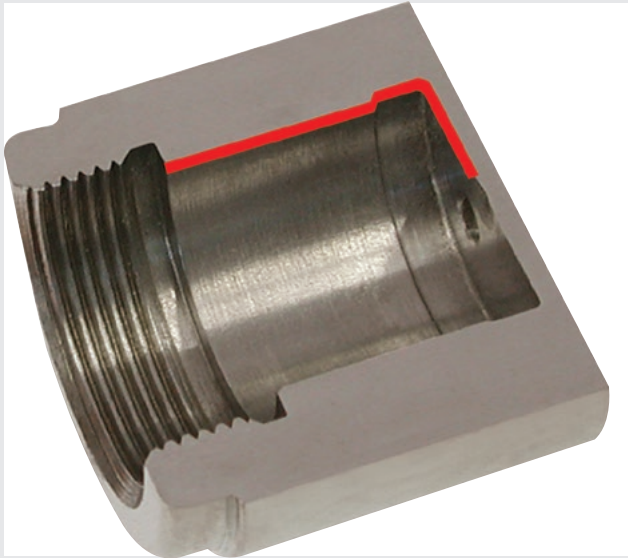

Technical data

Work piece	piston
Material	1.756 35SPb20+C
Tensile strength	-
Tool	PMC 16R-1.5D
Insert	PM 16RG 252004-M20 CTC1435
Competitor	2 tools

		CERATIZIT	Competitor
v_c	[m/min]	105	105
a_p	[mm]	0,03 - 5,0	0,3 - 5,0
$f_{turning}$	[mm]	0,15	0,1
$f_{grooving}$	[mm]	0,06	0,06

Criteria

- Increase in productivity
- Insufficient quality of groove surface

Result

- Machining time reduced by 50%
- Enhanced groove quality



Introduction

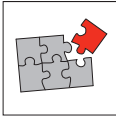

Product extensions

#R01#

Solid carbide tools for milling



Introduction

#R01#

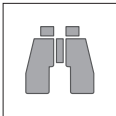

Overview

#R02#



Material group UN

#R03#

Technical information

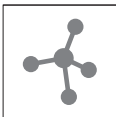

Comparison of materials

#R01#

Index



Index

#R01#

Solid carbide tools

Extended product range

F3



High performance x 2

A new generation of end mills

HPC2 W4420 - for universal application:

HPC milling cutters reach higher metal removal rates than conventional end mills. The development of our new HPC2 W4420 end mill has set new standards in the field of HPC machining. Maximum metal removal rates are achieved thanks to high feed rates and at large depths of cut. The geometry of the tool was specially designed for the requirements of this type of machining. Excellent cutting action together with reduced vibration during the milling operation ensures good surface quality.

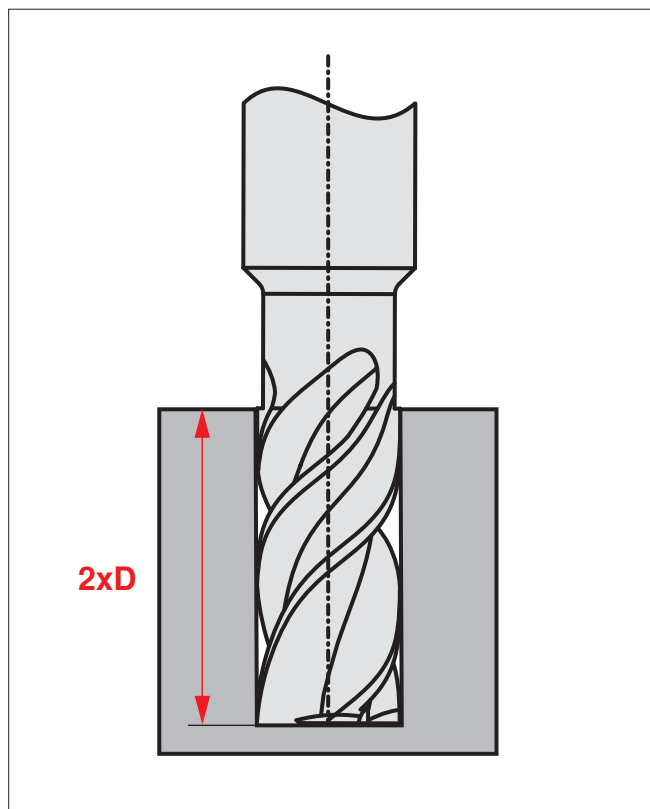

Your advantages

- ▲ Excellent chip evacuation also when full-slot milling
- ▲ Excellent cutting action due to very positive rake angle
- ▲ Milling operation with reduced vibration and large depths of cut for improved process security
- ▲ Low stress on the spindle – protection of the machine
- ▲ Long tool life and cutting parameters thanks to grade SCPP225 and special micro-geometries
- ▲ Ground neck for large depths of cut



Your benefits

- ▲ Maximum productivity due to high metal removal rates
- ▲ Longer tool life with the same metal removal rates for reduced tooling costs
- ▲ Secure production processes through increased process security

HPC2 W4420 end mills

We offer the new solid carbide cutting tool with 4 cutting edges in diameters from 3 mm to 20 mm for common steel materials, stainless steels, cast iron and non-ferrous metals. The geometries specially created for this milling cutter combine the

advantages of small and large rake angles as well as variable core diameters for deep chip pockets in one tool.

HPC2-SF		Ø ranges		Through-coolant	Tolerances	Helix angle	Rake angle	Grade
	W4420	3 – 20	4		$d_1 = f8 / d_A = h6$	$\lambda_s = \begin{matrix} 22-42^\circ \\ 17-40^\circ \end{matrix}$	$\gamma_s = 14^\circ$	SCPP225

The universal tool for very high metal removal rates

The HPC2 W4420 end mill combines various characteristics for maximum metal removal rates: the SCPP225 grade, together with the special micro-geometry on the front and peripheral cutting edges, provides long tool life and high cutting parameters. Also possible are great depths of cut $> 1.5xD$ with very high feed rates. Thanks to the ground neck, deep pockets can be machined. Furthermore, the irregular pitch of the tool reduces vibration and guarantees low cutting noise. The variable core diameter and the variable helix increase stability providing quick and secure chip evacuation.

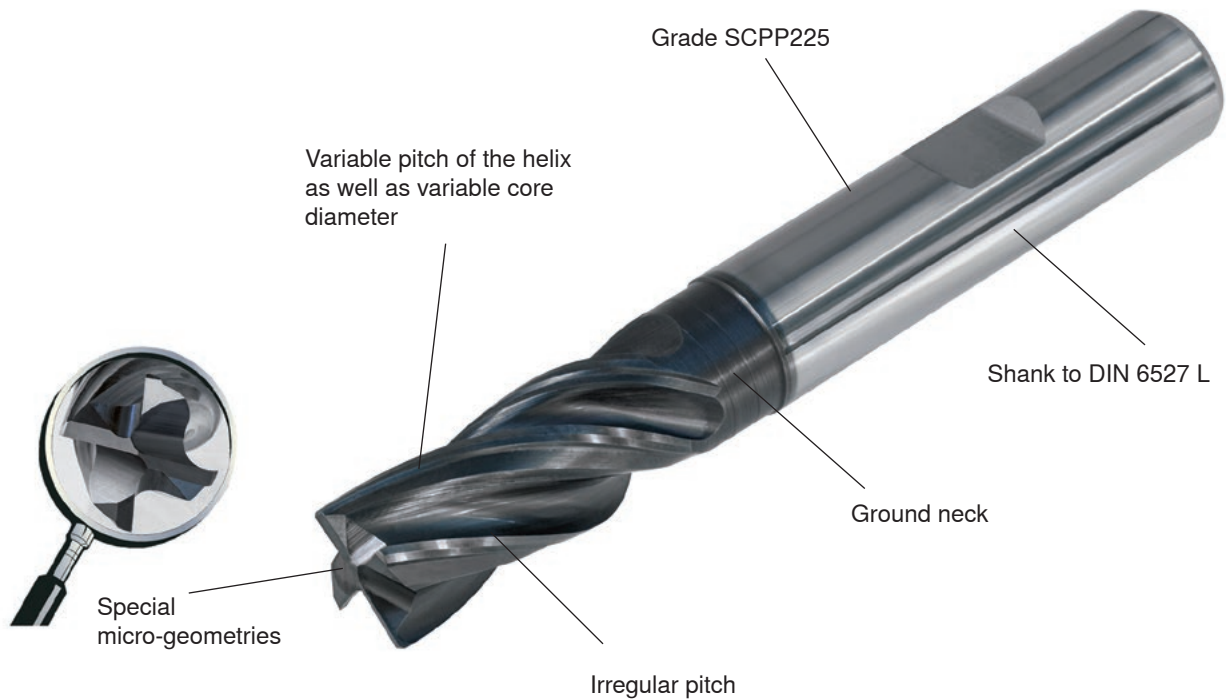
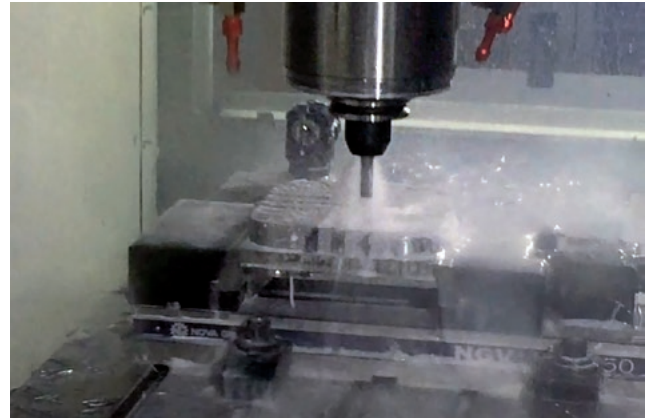

A practical example

Material: non-alloyed steel, annealed
0.15 % - 0.45 % C (VDI 3323 group 2)

	Competitor	CERATIZIT
Cutter Ø [mm]	16	16
a_e [mm]	16	16
a_p [mm]	32 (2xD)	32 (2xD)
V_c [m/min]	90	90
n [min ⁻¹]	1800	1800
f_z [mm]	0,05	0,05
V_f [mm/min]	360	360
Quantity	200	280

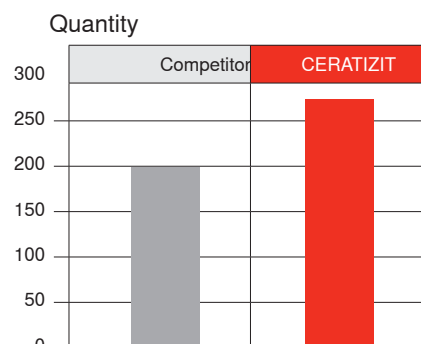

Solid carbide tools

Extended product range



HPC2 W4420 - with different variable rake angles

Increasing helix angle

The continuously increasing helix angle of 17° or 22° to 40° or 42°, unites the advantages of a small and a large helix angle.

Low cutting forces and quicker chip evacuation and formation make for low cutting noise and reduced vibration ensuring good surface quality with high cutting parameters.

Variable core diameter

Due to the gradually increasing helix angle, the core diameter has been adapted to optimise chip evacuation. The HPC2 W4420 end mill thus ensures consistent metal removal rates thanks to the deeper helical flutes.

To guarantee sufficient stability of the HPC2 W4420, however, the core diameter was reduced variably and implemented with only two flutes.

Irregular pitch

The irregular pitch ensures smooth cutting action even with substantial depths of cut, making for low cutting noise and low vibration.

"Excellent stability combined with optimal chip evacuation."

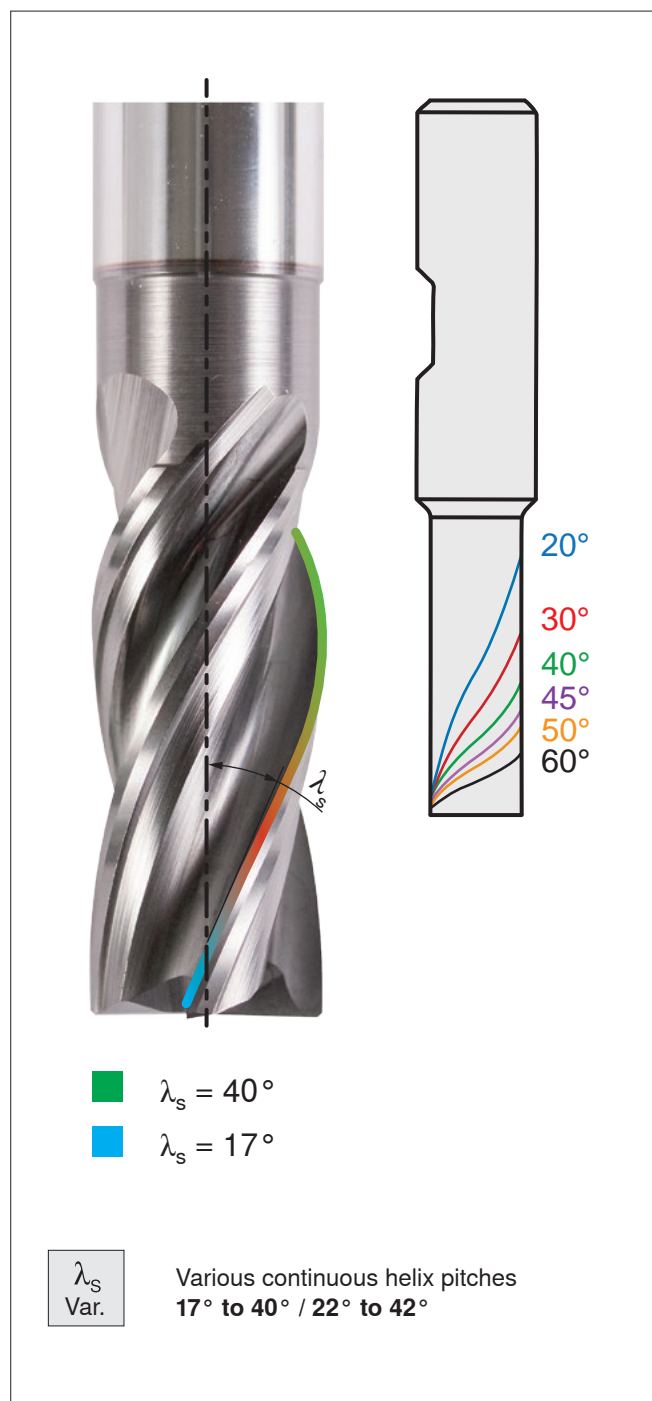

The following illustration compares a HPC cutter with irregular pitch to a HPC2 end mill additionally characterised by a variable helix angle and core diameter. It shows the 'linear' length of the cutting edge or length of the helical flutes of the tools. This

points out the difference of the variable helix angle of a HPC2 W4420 end mill when compared with a solid carbide milling cutter commonly used on the market, one that has a constant helix angle over the entire length of the groove.

Tool with irregular pitch

HPC2 tool with irregular pitch and variable helix angle

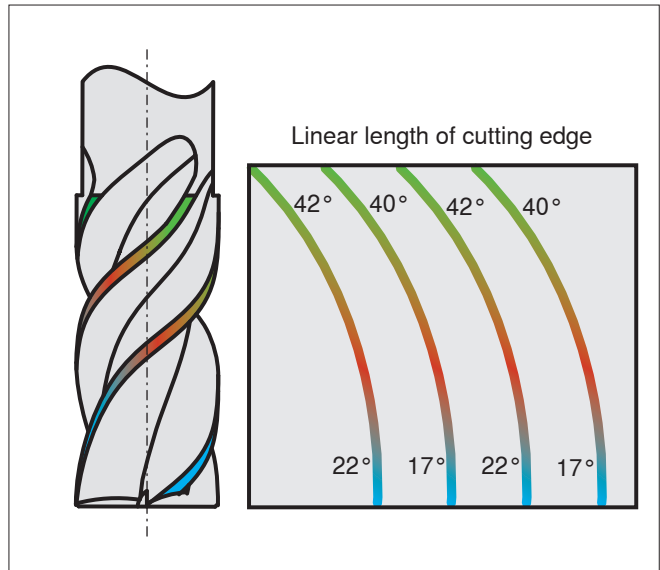
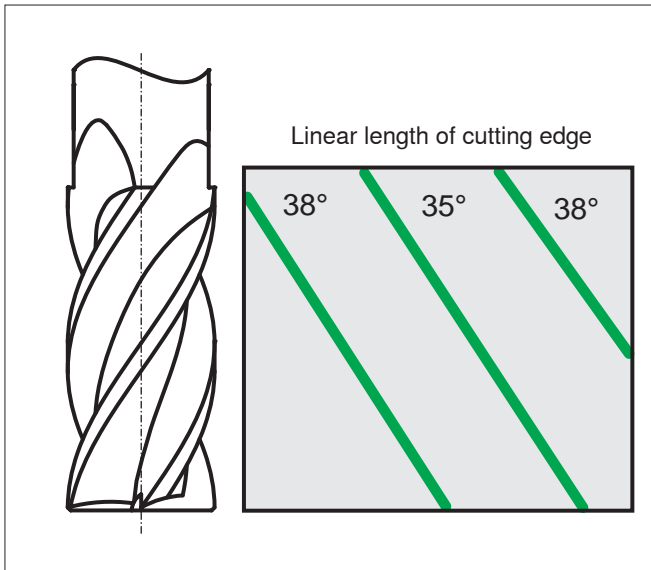

Resulting forces

Compared to competitor tools, the HPC2 tool exhibits notably lower forces generated by the tool (see chart). Improvements in tool life of up to 45% are achieved when the cutting forces

are equal.

Material: non alloyed steel, annealed
1.2379 X155 Cr V Mo 121

	Competitor	CERATIZIT
Cutter Ø [mm]	10	10
a_e [mm]	10	10
a_p [mm]	10 (1xD)	10 (1xD)
V_c [m/min]	160	160
n [min ⁻¹]	5093	5093
f_z [mm]	0,05	0,05
V_f [mm/min]	1019	1019
Tool life [m]	7,8	11,3

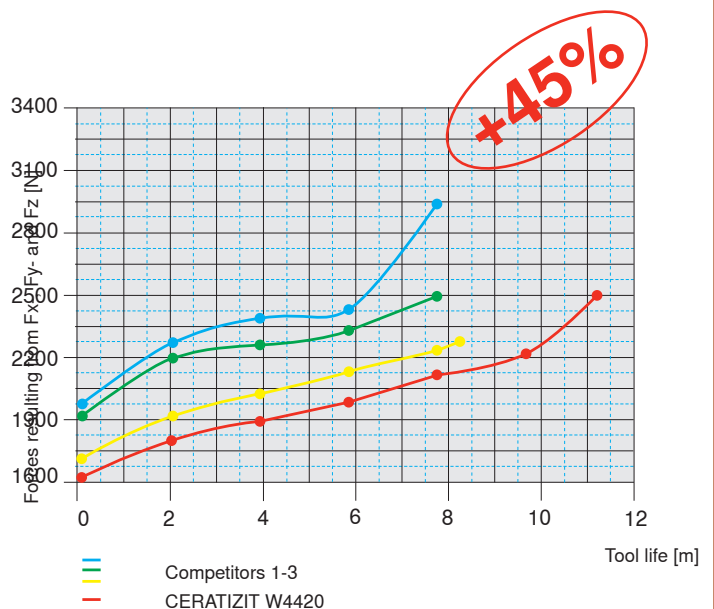

Designation system - tools

Solid carbide tools for milling

MRO . V . 0839 . 0800 . L

1 2 3 4 5

1

Tool group	
HPC2-SF	HPC2 end mills
HPC-SF	- HPC end mills
SF	- end mills
SFM	- mini end mills
CPC-SF	- CPC end mills (Circle Power Cutting)
HPC-SR	- HPC rough milling cutters
SR	- rough milling cutters
SRS	- rough and finish milling cutters
VR	- ball nose milling cutters
HPC-TF	- HPC torus milling cutters
TF	- torus milling cutters
MSF	- micro end mills
MVR	- micro ball nose milling cutters
MTF	- micro torus milling cutters
HG-SC	- high-precision finish milling cutters
SC	- finish milling cutters
EZ	- single flute milling cutters
E	- deburring cutters
FF	- chamfer milling cutters
R	- solid carbide milling cutters for plastics
MRO	- multiple milling cutters for plastics

3

Type

4

Ø d₁
0600 > Ød1 = 6,00 mm

5

Length	
XS	- extra-short
S	- short
L	- long
LS	- long S
OL	- very long
OLS	- very long S
XL	- extra-long

2

Material main application	
UN	- universal
ST	- steel
VA	- stainless steel
TI	- titanium
H	- hardened steel
AL	- aluminium
V	- composite materials

Z6 . F0020A . HA | SCPX215

6

7

8

9

6

Number of teeth

8

Shank

HE
HA
HB

7

Corner radius, chamfer					
F	chamfer	1st to 4th position	size	0040	0.40 mm
		5th position	angle	A	45°
				D	60°
				E	75°
				F	85°
R	radius	0005	R = 0.05		
		0400	R = 4.00		
S	sharp				

9









Grade





Explanation of symbols

Solid carbide tools for milling

F9



UN	Material group, e.g. UN = universal
	Length, e.g. short
EZ	Tool group, e.g. EZ = single flute milling cutters
σ 120°	Cutting edge angle, e.g. for chamfer milling cutters
	without through coolant
	with through coolant
E 	Emulsion recommended
D 	Compressed air recommended
E/D 	Emulsion or compressed air recommended
	Possible machining directions
	Machining example
$\lambda_s = 44,5^\circ$ $46,5^\circ$	Helix angle

λ_s Var.	Variable helix angle
	Number of teeth
HA 	Shanks to DIN6535-HA
HB 	Shanks to DIN6535-HB
HE 	Shanks to DIN6535-HE
$\gamma_s = 20^\circ$	Rake angle
S	Sharp cutting edge
F 45°	Cutting edge with chamfer F = chamfer width [mm]
R	Radius corner bull nose R = radius [mm]
R	Fully radiused end ball nose R = radius [mm]
$d_1 = e8$ $d_A = h6$	Tolerance cutting edge diameter Tolerance shank diameter
	Undersize milling cutters

Explanation of the table

Solid carbide tools for milling

UN

**HPC
SF**

$\lambda_s = 35^\circ$
 38°

$\gamma_s = 8^\circ$

$d_1 = f8$
 $d_A = h6$

F
45°

E

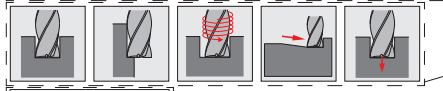

SCPP215

Grade

Application/
geometry

Machining possibilities

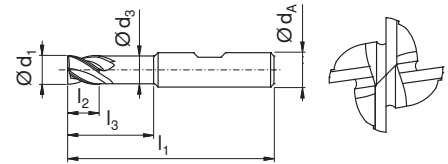

Length/shank type

d_1 [mm]	Type, description	d_A [mm]	d_3 [mm]	l_1 [mm]	l_2 [mm]	l_3 [mm]	F [mm]	z	Material
6.0	HPC-SF.UN.0451.0600.LS.Z4.F0010A.HB	6	5.8	57	7	19	0.1	4	W0451060R41

Material short text

Dimensions

Material number





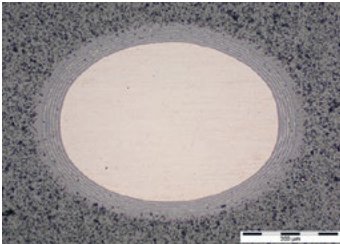

Grade overview, grade description

Solid carbide tools for milling



Grade designation	Standard designation		*Type of cutting material	Application range	P	M	K	N	S	H
	ISO	ANSI			Steel	Stainless	Cast iron	Non-ferrous metals	Heat-resistant	Hard materials
SCPP225	HC-P25	C6	P	01 05 10 15 20 25 30 35 40 45 50	●	○	○	○	○	
				01 05 10 15 20 25 30 35 40 45 50	● Main application ○ Extended application					

SCPP225	HC-P25	● ○ ○ ○ ○
	<p>Specification: Grain size: submicron / 0.7 μm Hardness: HV₃₀ 1600 Coating specification: Ti Al C N Coating structure: multi-layer (stacked structure)</p> <p>Recommended application: Good combination of carbide and coating for universal application.</p>	

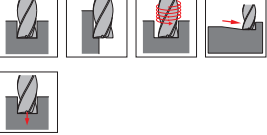
Tool type	Length	Ø-range [mm]	Number of teeth	Helix angle	Rake angle	Int. coolant supply	Cutting edge form	Shank	Machining direction	Machining method	Page(s)
UN	HPC2 SF	HPC2 end mills, coated									
W4420		 3.0 - 20.0	Z4	$\lambda_s = \frac{17^\circ}{42^\circ}$	$\gamma_s = 14^\circ$			HB 			#R01#

W4420-L, coated

HPC2 end mills

F13



Index	Material designation	V _c [m/min]	a _e max. [mm]	a _p max. [mm]	f _z [mm]				
					= Ø 3,0 = Ø 4,0	> Ø 4,0 = Ø 8,0	> Ø 8,0 = Ø 12,0	> Ø 12,0 = Ø 16,0	> Ø 16,0 = Ø 20,0
1.1.1	Machining steels	260	1xØ	2xØ	0,028	0,05	0,08	0,12	0,14
1.1.2		240	1xØ	2xØ	0,025	0,045	0,07	0,1	0,12
1.2.1	Constructional steel	250	1xØ	2xØ	0,028	0,05	0,08	0,12	0,14
1.2.2		230	1xØ	2xØ	0,025	0,045	0,07	0,1	0,12
1.2.3		220	1xØ	2xØ	0,025	0,045	0,07	0,1	0,12
1.3.1	Spring steel								
1.3.2									
1.3.3									
2.1.1	Cementation steel	210	1xØ	2xØ	0,025	0,045	0,07	0,1	0,12
2.1.2		200	1xØ	2xØ	0,025	0,045	0,07	0,1	0,12
2.1.3		190	1xØ	2xØ	0,02	0,04	0,06	0,08	0,1
2.2.1	Nitriding steel	190	1xØ	2xØ	0,025	0,045	0,07	0,1	0,12
2.2.2		170	1xØ	2xØ	0,02	0,04	0,06	0,08	0,1
2.3.1	Tempered steel	200	1xØ	2xØ	0,025	0,045	0,07	0,1	0,12
2.3.2		190	1xØ	2xØ	0,025	0,045	0,07	0,1	0,12
2.3.3		190	1xØ	2xØ	0,025	0,045	0,07	0,1	0,12
2.3.4		180	1xØ	2xØ	0,025	0,045	0,07	0,1	0,12
2.3.5		170	1xØ	2xØ	0,02	0,04	0,06	0,08	0,1
2.3.6		150	1xØ	2xØ	0,02	0,04	0,06	0,08	0,1
3.1.1	Non alloyed tool steel	180	1xØ	2xØ	0,025	0,045	0,07	0,1	0,12
3.2.1	Tool steel for cold working	180	1xØ	2xØ	0,025	0,045	0,07	0,1	0,12
3.2.2		170	1xØ	2xØ	0,025	0,045	0,07	0,1	0,12
3.2.3		150	1xØ	2xØ	0,02	0,04	0,06	0,08	0,1
3.2.4		160	1xØ	2xØ	0,025	0,045	0,07	0,1	0,12
3.2.5		140	1xØ	2xØ	0,025	0,045	0,07	0,1	0,12
3.3.1	Tool steel for hot working	200	1xØ	2xØ	0,025	0,045	0,07	0,1	0,12
3.3.2		180	1xØ	2xØ	0,02	0,04	0,06	0,08	0,1
3.3.3		150	1xØ	2xØ	0,025	0,045	0,07	0,1	0,12
3.3.4		140	1xØ	2xØ	0,025	0,045	0,07	0,1	0,12
3.3.5		130	1xØ	2xØ	0,02	0,04	0,06	0,08	0,1
3.5.1	Hardened tool steel	< 55 HRC							
3.5.2		55–58 HRC							
3.5.3		58–60 HRC							
3.5.4		60–62 HRC							
3.5.5		62–64 HRC							
4.1.1	Stainless steel	120	1xØ	1,5xØ	0,012	0,025	0,04	0,05	0,07
4.1.2		100	1xØ	1,5xØ	0,012	0,025	0,04	0,05	0,07
4.1.3		120	1xØ	1,5xØ	0,012	0,025	0,04	0,05	0,07
4.1.4		120	1xØ	1,5xØ	0,012	0,025	0,04	0,05	0,07
4.1.5		130	1xØ	1,5xØ	0,012	0,025	0,04	0,05	0,07
4.2.1	Heat-resistant alloys								
4.2.2									
4.2.3									
4.2.4									
5.1.1	Conventional cast steel	200	1xØ	2xØ	0,025	0,045	0,07	0,1	0,12
5.1.2		160	1xØ	2xØ	0,025	0,045	0,07	0,1	0,12
5.1.3		140	1xØ	2xØ	0,025	0,045	0,07	0,1	0,12
5.2.1	Stainless cast steel	120	1xØ	2xØ	0,015	0,03	0,05	0,06	0,08
5.2.2		120	1xØ	2xØ	0,015	0,03	0,05	0,06	0,08
6.1.1	Cast iron with lamellar graphite	200	1xØ	2xØ	0,028	0,05	0,08	0,12	0,14
6.1.2		180	1xØ	2xØ	0,028	0,05	0,08	0,12	0,14
6.1.3		160	1xØ	2xØ	0,025	0,045	0,07	0,1	0,12
6.1.4		120	1xØ	2xØ	0,025	0,045	0,07	0,1	0,12
6.2.1	Spheroidal cast iron	190	1xØ	2xØ	0,025	0,045	0,07	0,1	0,12
6.2.2		170	1xØ	2xØ	0,025	0,045	0,07	0,1	0,12
6.2.3		150	1xØ	2xØ	0,025	0,045	0,07	0,1	0,12
6.3.1	GTW (white malleable cast iron)	180	1xØ	2xØ	0,025	0,045	0,07	0,1	0,12
6.3.2		160	1xØ	2xØ	0,025	0,045	0,07	0,1	0,12
6.4.1	GTS (black malleable cast iron)	180	1xØ	2xØ	0,025	0,045	0,07	0,1	0,12
6.4.2		160	1xØ	2xØ	0,025	0,045	0,07	0,1	0,12
7.1.1	Aluminium								
7.1.2									
7.1.3									
7.1.4									
7.1.5									
7.1.6									
7.2.1	Magnesium								
7.2.2									
7.3.1	Copper	280	1xØ	2xØ	0,028	0,05	0,08	0,12	0,14
7.3.2		240	1xØ	2xØ	0,028	0,05	0,08	0,12	0,14
7.3.3		200	1xØ	2xØ	0,028	0,05	0,08	0,12	0,14
7.3.4		240	1xØ	2xØ	0,028	0,05	0,08	0,12	0,14
7.3.5		200	1xØ	2xØ	0,028	0,05	0,08	0,12	0,14
7.3.6		240	1xØ	2xØ	0,028	0,05	0,08	0,12	0,14
7.4.1	CuZn (brass)	300	1xØ	2xØ	0,028	0,05	0,08	0,12	0,14
7.4.2		350	1xØ	2xØ	0,028	0,05	0,08	0,12	0,14
7.5.1	CuSn (bronze)	240	1xØ	2xØ	0,028	0,05	0,08	0,12	0,14
7.5.2		280	1xØ	2xØ	0,028	0,05	0,08	0,12	0,14
7.6.1	CuAlFe (Ampco)	140	1xØ	2xØ	0,028	0,05	0,08	0,12	0,14
7.6.2		160	1xØ	2xØ	0,028	0,05	0,08	0,12	0,14
7.8.1	Titanium								
7.8.2									
7.8.3									

W4420-L, coated

HPC2 end mills

F14



UN	HPC2 SF							
λ_s Var.	$\lambda_s = \begin{matrix} 17^\circ \\ 42^\circ \end{matrix}$	$\gamma_s = 14^\circ$	$d_s = f8$ $d_A = h6$					
SCPP225								

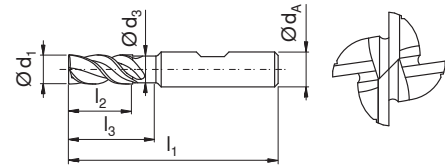

d_1 [mm]	Type, description	d_A [mm]	d_3 [mm]	l_1 [mm]	l_2 [mm]	l_3 [mm]	F [mm]	z	HB	Material
3.0	HPC2-SF.UN.4420.0300.L.Z4.F0010A.HB	6	2.8	57	8	13	0.1	4		W4420030341
4.0	HPC2-SF.UN.4420.0400.L.Z4.F0010A.HB	6	3.8	57	11	17	0.1	4		W4420040341
5.0	HPC2-SF.UN.4420.0500.L.Z4.F0010A.HB	6	4.8	57	13	19	0.1	4		W4420050341
6.0	HPC2-SF.UN.4420.0600.L.Z4.F0010A.HB	6	5.8	57	13	19	0.1	4		W4420060341
8.0	HPC2-SF.UN.4420.0800.L.Z4.F0020A.HB	8	7.7	63	21	25	0.2	4		W4420080341
10.0	HPC2-SF.UN.4420.1000.L.Z4.F0020A.HB	10	9.7	72	22	30	0.2	4		W4420100341
12.0	HPC2-SF.UN.4420.1200.L.Z4.F0030A.HB	12	11.6	83	26	36	0.3	4		W4420120341
16.0	HPC2-SF.UN.4420.1600.L.Z4.F0030A.HB	16	15.5	92	36	42	0.3	4		W4420160341
20.0	HPC2-SF.UN.4420.2000.L.Z4.F0030A.HB	20	19.5	104	41	52	0.3	4		W4420200341

Notes

F15





Technical information

Material table

F17



Material main group	Material sub-group	Quality	StNr	DIN	AFNOR	UNI	BS	JIS	SS	GOST	UNS	USA		
1 Machining, constructional and spring steel	1.1 Machining steels	1.1.1 up to 500 N/mm ²	1.0711	9 S 20		CF 9 S 22	220 M 07	SUM 21			G 12120	1212		
			1.0715	9 SMn 28	S 250	CF 9 SMn 28	230 M 07	SUM 22	1912		G 12130	1213		
			1.0718	9 SMnPb 28	S 250 Pb	CF 9 SMnPb 28		SUM 22 L	1914		G 12134	12 L 13		
			1.0721	10 S 20	10 F 1	CF 10 S 20	210 M 15					1108		
			1.0722	10 SPb 20	10 PbF 2	CF 10 SPb 20						11 L 08		
			1.0723	15 S 20			210 A 15	SUM 32	1922					
			1.0736	9 SMn 36	S 300	CF 9 SMn 36	240 M 07				G 12150	1215		
		1.0737	9 SMnPb 36	S 300 Pb	CF 9 SMnPb 36			1926		G 12144	12 L 14			
		1.0726	35 S 20	35 MF 4		212 M 36		1957		G 11400	1140			
		1.0727	45 S 20	45 MF 4		212 M 44		1973		G 11460	1146			
		1.0728	60 S 20	60 MF 4										
		1.0037	1.2.1 non alloyed up to 500 N/mm ²	St 37-2				STKM 12 C						
		1.0044	1.2.1 non alloyed up to 500 N/mm ²	St 44-2	E 24-2	Fe 430 B FN	4360-43 B	SM 41 B	1412				A 570 Gr. 40	
		1.0116	1.2.1 non alloyed up to 500 N/mm ²	St 37-3	E 24-3; E 24-4	Fe 360 D FF	4360-40 C		1312; 1313	St 3 kp; ps; sp			A 573 Gr. 58	
	1.0144	1.2.1 non alloyed up to 500 N/mm ²	St 44-3	E 28-3; E 28-4	Fe 430 D FF	4360-43 C	SM 41 C	1412; 1414	St 4 kp; ps; sp			A 573 Gr. 70		
	1.0050	1.2.2 non alloyed above 500 N/mm ²	St 50-2	A 50-2	Fe 490	4360-50 B	SS 50	2172	BSt 5 ps; sp			A 570 Gr. 50		
	1.0060	1.2.2 non alloyed above 500 N/mm ²	St 60-2	A 60-2	Fe 590; Fe 60-2	4360-SSE; SSC	SM 58		St 6 ps; sp					
	1.0570	1.2.2 non alloyed above 500 N/mm ²	St 52-3	E 36-3; E 36-4	Fe 510 B; C; D	4360-50 B	SM 50 YA	2132	17 GS					
	1.5415	1.2.3 alloyed	15 Mo 3	15 D 3	16 Mo 3	1501-240			2912				A 204 Gr. A	
	1.5423	1.2.3 alloyed	16 Mo 5		16 Mo 5	1503-245-420						G 45200	4520	
	1.5622	1.2.3 alloyed	14 Ni 6	16 N 6	14 Ni 6								A 350-LF 5	
	1.5680	1.2.3 alloyed	12 Ni 19	Z 18 N 5									2515	
	1.7335	1.2.3 alloyed	13 CrMo 4 4	15 CD 3.5	14 CrMo 4 5	1501-620 Gr. 27			2216	12ChM; 15ChM			A 182-F11; F12	
	1.7337	1.2.3 alloyed	16 CrMo 4 4	15 CD 4.5	14 CrMo 4 5	1501-620 Gr. 27			2216	15ChM			A 387 Gr. 12 Cl. 2	
	1.7380	1.2.3 alloyed	10 CrMo 9 10	10 CD 9.10	12 CrMo 9 10	1501-622 Gr. 31; 45			2218			J 21890	A 182-F22	
	1.7709	1.2.3 alloyed	21 CrMoV 5 7											
	1.7715	1.2.3 alloyed	14 MoV 6 3			1503-660-440								
	1.7735	1.2.3 alloyed	14 CrMoV 6 9	15 CDV 6										
	1.0904	1.3 Spring steel	1.3.1 annealed (up to 250 HB)	1.0904	55 Si 7	55 S 7	55 Si 8	250 A 53		2085; 2090	55S2		9255	
	1.0961			60 SiCr 7	60 SC 7	60 SiCr 8		SUP 7					9262	
	1.1231			Ck 67	XC 68	C 70	060 A 67			1770	70	G 10700	1070	
	1.1248			Ck 75	XC 75	C 75	060 A 78			1774; 1778	75	G 10780	1078; 1080	
	1.1274			Ck 101	XC 100		060 A 96	SUP 4		1870		G 10950	1095	
	1.2101			62 SiMnCr 4										
	1.2103			58 SiCr 8										
	1.7103			67 SiCr 5										
	1.7176			55 Cr 3	55 C 3	55 Cr 3	527 A 60	SUP 9 (A)		2253	50ChGA	G 51550	5155	
	1.8159		50 CrV 4	50 CV 4	51 CrV 4	735 A 50	SUP 10		2230	50ChGFA	G 61500	6150		
	1.0904		1.3.2 naturally hard materials	1.3.1 annealed (up to 250 HB)	1.0904	55 Si 7	55 S 7	55 Si 8	250 A 53		2085; 2090	55S2		9255
	1.0961				60 SiCr 7	60 SC 7	60 SiCr 8		SUP 7					9262
	1.1231				Ck 67	XC 68	C 70	060 A 67			1770	70	G 10700	1070
	1.1248				Ck 75	XC 75	C 75	060 A 78			1774; 1778	75	G 10780	1078; 1080
1.1274	Ck 101				XC 100		060 A 96	SUP 4		1870		G 10950	1095	
1.2101	62 SiMnCr 4													
1.2103	58 SiCr 8													
1.7103	67 SiCr 5													
1.7176	55 Cr 3	55 C 3			55 Cr 3	527 A 60	SUP 9 (A)		2253	50ChGA	G 51550	5155		
1.8159	50 CrV 4	50 CV 4	51 CrV 4	735 A 50	SUP 10		2230	50ChGFA	G 61500	6150				
1.0904	1.3.3 hard materials for spring steel	1.3.1 annealed (up to 250 HB)	1.0904	55 Si 7	55 S 7	55 Si 8	250 A 53		2085; 2090	55S2		9255		
1.0961			60 SiCr 7	60 SC 7	60 SiCr 8		SUP 7					9262		
1.1231			Ck 67	XC 68	C 70	060 A 67			1770	70	G 10700	1070		
1.1248			Ck 75	XC 75	C 75	060 A 78			1774; 1778	75	G 10780	1078; 1080		
1.1274			Ck 101	XC 100		060 A 96	SUP 4		1870		G 10950	1095		
1.2101			62 SiMnCr 4											

Material main group	Material sub-group	Quality	StNr	DIN	AFNOR	UNI	BS	JIS	SS	GOST	UNS	USA		
1 Machining, constructional and spring steel	1.3 Spring steel	hard materials for spring steel	1.2101	62 SiMnCr 4										
			1.2103	58 SiCr 8										
			1.7103	67 SiCr 5										
			1.7176	55 Cr 3	55 C 3	55 Cr 3	527 A 60	SUP 9 (A)	2253	50ChGA	G 51550	5155		
			1.8159	50 CrV 4	50 CV 4	51 CrV 4	735 A 50	SUP 10	2230	50ChGFA	G 61500	6150		
2 Cementation, nitriding and tempered steel	2.1 Cementation steel	2.1.1 up to 150 HB	1.0301	C 10	AF 34 C 10; XC 10	C 10	045 M 10	S 10 C		10	G 10100	1010		
			1.0401	C 15	AF3 7 C 12; XC 18	C 15; C 16	080 M 15		1350		G 10170	1015		
			1.1121	Ck 10	XC 10	C 10	045 M 10	S 10 C; S 9 CK	1265	08; 10	G 10100	1010		
			1.1141	Ck 15	XC 15; XC 18	C 15; C 16	080 M 15	S 15 C; S 15 CK	1370	15	G 10170	1015		
			1.7012	13 Cr 2										
			1.7015	15 Cr 3	12 C 3		523 M 15	SCR 415 (H)		15Ch	G 50150	5015		
		2.1.2 150 - 200 HB	2.1.3 above 200 HB	1.5732	14 NiCr 10	14 NC 11	16 NiCr 11			SNC 415 (H)				3415
				1.5752	14 NiCr 14	12 NC 15		655 M 13	SNC 815 (H)			G 33106	3310; 9314	
				1.5860	14 NiCr 18									
				1.5919	15 CrNi 6	16 NC 6	16 CrNi 4	S 107						
				1.5920	18 CrNi 8	20 NC 6								
				1.6523	21 NiCrMo 2	20 NCD 2	20 NiCrMo 2	805 M 20	SNM 220 (H)	2506		G 86170	8620	
				1.6587	17 CrNiMo 6	18 NCD 6	18 NiCrMo 7	820 A 16						
				1.7131	16 MnCr 5	16 MC 4	16 MnCr 5	527 M 17	SCR 415	2511	18ChG	G 51170	5115	
				1.7139	16 MnCrS 5									
				1.7147	20 MnCr 5	20 MC 5	20 MnCr 5		SMnC 420 (H)		18ChG	G 51200	5120	
				1.7149	20 MnCrS 5									
				1.7262	15 CrMo 5	12 CD 4	12 CrMo 4		SCM 415 (H)					
				1.7264	20 CrMo 5	18 CD 4			SCM 421					
	1.7271			23 CrMoB 3 3										
	1.7311			20 CrMo 2										
	1.7321			20 MoCr 4										
	1.7323			20 MoCrS 4										
	1.7325	25 MoCr 4												
	1.7326	25 MoCrS 4												
	2.2 Nitriding steel	2.2.1 up to 1000 N/mm ²	1.8504	34 CrAl 6										
			1.8506	34 CrAlS 5								K 23745		
			1.8507	34 CrAlMo 5	30 CAD 6.12	34 CrAlMo 7	905 M 31				K 23545	A 355 Cl. D		
			1.8509	41 CrAlMo 7	40 CAD 6.12	41 CrAlMo 7	905 M 39	SACM 645	2940	38ChMJuA	K 24065	A 355 Cl. A		
			1.8515	31 CrMo 12	30 CD 12	31 CrMo 12	722 M 24		2240					
			1.8519	31 CrMoV 9										
		2.2.2 above 1000 N/mm ²	1.8521	15 CrMoV 5 9										
			1.8523	39 CrMoV 13 9		36 CrMoV 13 9	897 M 39							
1.8550			34 CrAlNi 7								K 52440			
2.3 Tempered steel			2.3.1 non alloyed up to 800 N/mm ²	1.0402	C 22	AF 42 C 20	C 20; C 21	050 A 20			1450	20	G 10200	1020
	1.0406	C 25		AF 50 C 30	C 25	070 M 26						1025		
	1.0501	C 35		AF 55 C 35	C 35	060 A 35		1550	35	G 10350	1035			
	1.0503	C 45		AF 65 C 45	C 45	080 M 46		1650	45	G 10430	1045			
	1.0511	C 40		AF 60 C 40	C 40							1040		
	1.0528	C 30												
	1.1151	Ck 22		XC 25; XC 18	C 20	050 A 20	S 20 C; S 20 CK		20			1023		
	1.1158	Ck 25		XC 25	C 25	070 M 26	S 25 C		25	G 10250	1025			
	1.1178	Ck 30												
	1.1181	Ck 35		XC 38 H1; XC 32	C 35	080 M 36	S 35 C	1572	35	G 10340	1035			
	1.1186	Ck 40		XC 42 H1	C 40	080 M 40	S 40 C		40			1040		
	1.1191	Ck 45		XC 42	C 45	080 M 46	S 45 C	1672	45	G 10420	1045			

Technical information

Material table

F19



Material main group	Material sub-group	Quality	StNr	DIN	AFNOR	UNI	BS	JIS	SS	GOST	UNS	USA	
2 Cementation, nitriding and tempered steel	2.3 Tempered steel	2.3.2 non alloyed 800 - 1000 N/mm ²	1.0535	C 55	AF 70 C55	C 55	070 M 55		1655	55		1055	
			1.0540	C 50									
			1.0601	C 60	CC 55	C 60	080 A 62			60	G 10600	1060	
			1.1203	Ck 55	XC 55	C50	070 M 55	S 55 C		55		1055	
			1.1206	Ck 50	XC 48 H1		080 M 50			50		1050	
			1.1221	Ck 60	XC 60	C60	080 A 62	S 58 C	1665; 1678	60; 60G	G 10640	1060	
		2.3.3 alloyed up to 800 N/mm ²	1.1133	20 Mn 5	20 M 5	G 22 Mn 3	120 M 19	SMnC 420				G 10220	1022; 1518
			1.3505	100 Cr 6	100 C 6	100 Cr 6	534 A 99	SUJ 2	2258	SchCh 15	G 52986	52100	
			1.5120	38 MnSi 4									
			1.5121	46 MnSi 4									
			1.5141	53 MnSi 4									
			1.5710	36 NiCr 6	35 NC 6		640 A 35	SNC 236					3135
			1.6546	40 NiCrMo 2 2	40 NCD 2	40 NiCrMo 2 (KB)	311-Type 7	SNCM 240		38ChGNM	G 87400	8740	
			1.6565	40 NiCrMo 6			311-Type 6	SNCM 439		40Ch2N2MA		4340	
			1.7003	38 Cr 2	38 C 2	38 Cr 2							
			1.7006	46 Cr 2	42 C 2	45 Cr 2							5045
			1.7020	32 Cr 2									
			1.7030	28 Cr 4			530 A 30			30Ch		5130	
			1.7033	34 Cr 4	32 C 4	34 Cr 4 (KB)	530 A 32	SCr 430 (H)		35Ch	G 51320	5132	
			1.7218	25 CrMo 4	25 CD 4	25 CrMo 4 (KB)	1717 CDS 110	SCM 420; SCM 430	2225	30ChM	G 41300	4130	
			1.7220	34 CrMo 4	35 CD 4	35 CrMo 4	708 A 37	SCM 432; SCCrM 3	2234	AS38ChGM	G 41350	4135; 4137	
	1.7223		41 CrMo 4	42 CD 4 TS	41 CrMo 4	708 M 40	SCM 440	2244	40 ChFA	G 41420	4142; 4140		
	1.7225		42 CrMo 4	42 CD 4	42 CrMo 4	708 M 40	SCM 440 (H)	2244		G 41400	4142; 4140		
	1.7228		50 CrMo 4	50 CR MO4		708 A 47	SCM 445 (H)		50ChFA	G 41470	4150		
	1.8159		50 CrV 4	50 CV 4	51 CrV 4	735 A 50	SUP 10	2230	50ChGFA	G 61500	6150		
	2.3.4 alloyed 800 - 1000 N/mm ²		1.1157	40 Mn 4	35 M 5		150 M 36			40G	G 10390	1039	
			1.1165	30 Mn 5	35 M 5		120 M 36	SMn 433 H; SCMn 2		30GSL		1330	
		1.1167	36 Mn 5	40 M 5		150 M 36	SMn 438 (H); SCMn 3	2120	35G2; 35GL	G 13350	1335		
		1.1170	28 Mn 6	20 M 5	C 28 Mn	150 M 28	SCMn 1		30G		1330		
		1.3561	44 Cr 2										
		1.3563	43 CrMo 4										
		1.3565	48 CrMo 4			817 M 40	SNC 836						
		1.5120	38 MnSi 4										
		1.5121	46 MnSi 4										
		1.5122	37 MnSi 4										
		1.5131	50 MnSi 4										
		1.5141	53 MnSi 4										
		1.5223	42 MnV 7										
		1.5710	36 NiCr 6	35 NC 6		640 A 35	SNC 236					3135	
		1.5736	36 NiCr 10	30 NC 11	35 NiCr 9		SNC 631 (H)					3435	
		1.5755	31 NiCr 14	18 NC 13		653 M 31	SNC 836						
		1.6511	36 CrNiMo 4	40 NCD 3	38 NiCrMo 4 (KB)	816 M 40			40 ChN2MA	G 98400	9840		
1.6513		28 NiCrMo 4											
1.7003		38 Cr 2	38 C 2	38 Cr 2									
1.7006		46 Cr 2	42 C 2	45 Cr 2							5045		
1.7030		28 Cr 4			530 A 30			30Ch		5130			
1.7033	34 Cr 4	32 C 4	34 Cr 4 (KB)	530 A 32	SCr 430 (H)		35Ch	G 51320	5132				
1.7034	37 Cr 4	38 C 4	38 Cr 4	530 A 36	SCr 435 H		40Ch		5135				
1.7035	41 Cr 4	42 C 4	41 Cr 4	530 M 40	SCr 440 (H)		40Ch	G 51400	5140				
1.7218	25 CrMo 4	25 CD 4 S	25 CrMo 4 (KB)	1717 CDS 110	SCM 420; SCM 430	2225	30ChM	G 41300	4130				
1.7220	34 CrMo 4	35 CD 4	35 CrMo 4	708 A 37	SCM 432; SCCrM 3	2234	AS38ChGM	G 41350	4135; 4137				
1.7223	41 CrMo 4	42 CD 4 TS	41 CrMo 4	708 M 40	SCM 440	2244	40 ChFA	G 41420	4142; 4140				
1.7225	42 CrMo 4	42 CD 4	42 CrMo 4	708 M 40	SCM 440 (H)	2244		G 41400	4142; 4140				

Material main group	Material sub-group	Quality	StNr	DIN	AFNOR	UNI	BS	JIS	SS	GOST	UNS	USA			
2 Cementation, nitriding and tempered steel	2.3 Tempered steel	2.3.4 alloyed 800 - 1000 N/mm ²	1.7228	50 CrMo 4	50 CR MO4		708 A 47	SCM 445 (H)		50ChFA	G 41470	4150			
			1.7561	42 CrV 6											
			1.7735	14 CrMoV 6 9											
			1.8159	50 CrV 4	50 CV 4	51 CrV 4	735 A 50	SUP 10	2230	50ChGFA	G 61500	6150			
		2.3.5 alloyed 1000 - 1300 N/mm ²	1.3563	43 CrMo 4											
			1.3565	48 CrMo 4				817 M 40	SNC 836						
			1.5120	38 MnSi 4											
			1.5121	46 MnSi 4											
			1.5122	37 MnSi 4											
			1.5223	42 MnV 7											
			1.5710	36 NiCr 6	35 NC 6		640 A 35	SNC 236						3135	
			1.5736	36 NiCr 10	30 NC 11	35 NiCr 9		SNC 631 (H)						3435	
			1.5864	35 NiCr 18											
			1.6511	36 CrNiMo 4	40 NCD 3	38 NiCrMo 4 (KB)	816 M 40				40 ChN2MA	G 98400	9840		
			1.6580	30 CrNiMo 8	30 CND 8	30 NiCrMo 8	823 M 30	SNCM 431							
			1.6582	34 CrNiMo 6	35 NCD 6	35 NiCrMo 6 (KW)	817 M 40	SNCM 447	2541	38Ch2N2MA			4340		
			1.7033	34 Cr 4	32 C 4	34 Cr 4 (KB)	530 A 32	SCr 430 (H)		35Ch	G 51320	5132			
			1.7034	37 Cr 4	38 C 4	38 Cr 4	530 A 36	SCr 435 H		40Ch		5135			
			1.7035	41 Cr 4	42 C 4	41 Cr 4	530 M 40	SCr 440 (H)		40Ch	G 51400	5140			
			1.7045	42 Cr 4	42 C 4 TS	41 Cr 4	530 A 40	SCr 440	2245	40Ch		5140			
			1.7218	25 CrMo 4	25 CD 4 S	25 CrMo 4 (KB)	1717 CDS 110	SCM 420; SCM 430	2225	30ChM	G 41300	4130			
			1.7220	34 CrMo 4	35 CD 4	35 CrMo 4	708 A 37	SCM 432; SCCM 3	2234	AS38ChGM	G 41350	4135; 4137			
			1.7223	41 CrMo 4	42 CD 4 TS	41 CrMo 4	708 M 40	SCM 440	2244	40 ChFA	G 41420	4142; 4140			
			1.7225	42 CrMo 4	42 CD 4	42 CrMo 4	708 M 40	SCM 440 (H)	2244		G 41400	4142; 4140			
			1.7228	50 CrMo 4	50 CR MO4		708 A 47	SCM 445 (H)		50ChFA	G 41470	4150			
			1.7361	32 CrMo 12	30 CD 12	32 CrMo 12	722 M 24		2240						
			1.7561	42 CrV 6											
			1.7707	30 CrMoV 9											
			1.7735	14 CrMoV 6 9											
			1.8159	50 CrV 4	50 CV 4	51 CrV 4	735 A 50	SUP 10	2230	50ChGFA	G 61500	6150			
			1.8161	58 CrV 4											
			2.3.6 alloyed 1000 - 1600 N/mm ²	1.1273	90 Mn 4										
				1.5864	35 NiCr 18										
				1.6580	30 CrNiMo 8	30 CND 8	30 NiCrMo 8	823 M 30	SNCM 431						
				1.6582	34 CrNiMo 6	35 NCD 6	35 NiCrMo 6 (KW)	817 M 40	SNCM 447	2541	38Ch2N2MA		4340		
				1.6746	32 NiCrMo 14 5	35 NCD 14		830 M 31							
		1.7361		32 CrMo 12	30 CD 12	32 CrMo 12	722 M 24		2240						
		1.7707		30 CrMoV 9											
		1.7735		14 CrMoV 6 9											
		1.8161		58 CrV 4											
		3 Tool steel		3.1 Non alloyed tool steel	3.1.1 general	1.1520	C 70 W1								
						1.1525	C 80 W1	Y1 90; Y1 80	C 80 KU				U8A	T 72301	W 108
1.1620	C 70 W2														
1.1625	C 80 W2					C 80 KU	BW 1 B	SKC 3; SK 5; SK 6		U8; 80	T 72301	W 1			
1.1645	C 105 W2		Y2 105			C 100 KU		SK 3		U10	T 72301				
1.1654	C 110 W														
1.1663	C 125 W		Y2 120			C 120 KU		SK 2		U13	T 72301	W 112			
1.1673	C 135 W		Y2 140			C 140 KU		SK 1							
1.1730	C 45 W		Y3 42												
1.1740	C 60 W		Y3 55					SK 7							
1.1744	C 67 W														
1.1750	C 75 W						BW 1A			75		W 1			
1.1820	C 55 W														

Technical information

Material table

F21



Material main group	Material sub-group	Quality	StNr	DIN	AFNOR	UNI	BS	JIS	SS	GOST	UNS	USA				
3 Tool steel	3.1 Non alloyed tool steel	3.1.1 general	1.1830	C 85 W	Y3 90			SK 5								
			1.1545	C 105 W1	Y1 105	C 100 KU			1880	U10A	T 72301	W 110				
	3.2 Tool steel for cold working	3.2.1 low alloyed up to 1000 N/mm ²	1.2067	100 Cr 6	Y 100 C 6			BL 3				T 61203	L 3			
			1.2101	62 SiMnCr 4												
			1.2103	58 SiCr 8												
			1.2108	90 CrSi 5												
			1.2162	21 MnCr 5	20 NC 5					SCR 420 H						
			1.2210	115 CrV 3	100 C 3	107 CrV 3 KU							T 61202	L 2		
			1.2330	35 CrMo 4	34 CD 4	35 CrMo 4	708 A 37				2234	35 HM	T 51620	4135		
			1.2332	47 CrMo 4	42 CD 4	40 CrMo 4	708 M 40				2244			4142		
			1.2369	81 CrMov 42 16												
			1.2419	105 WCr 6	105 WC 13	107 WCr 5 KU						SKS 31	ChWG			
			1.2510	100 MnCrW 4	90 MWCV 5	95 MnWCr 5 KU	BO 1					SKS 3	2140	T 31501	O 1	
			1.2516	120 WV 4	110 WC 20	110 W 4 KU	BF 1									
			1.2542	45 WCrV 7		45 WCrV 8 KU	BS 1						2710	T 41901	S 1	
			1.2550	60 WCrV 7	55 WC 20	55 WCrV 8 KU										
			1.2721	50 NiCr 13												
			1.2735	15 NiCr 14	10 NC 12								SNC 22	T 51606		
			1.2762	75 CrMoNiW 6 7												
			1.2826	60 MnSiCr 4												
			1.2833	100 V 1	Y1 105 V	102 V 2 KU	BW 2						SKS 43	T 72302	W 210	
			1.2842	90 MnCrV 8	90 MV 8	90 MnVCr 8 KU	BO 2							T 31502	O 2	
			3.2.2 low alloyed up to 1200 N/mm ²	1.2312	40 CrMnMoS 8 6											
				1.2711	54 NiCrMoV 6	55 NCDV 6										
			3.2.3 low alloyed up to 1500 N/mm ²	1.2713	55 NiCrMoV 6	55 NCDV 7							SKT 4	5ChNM	T 61206	L 6
			3.2.4 high alloyed annealed	1.2080	X 210 Cr 12	Z 200 C 12	X 210 Cr 13 KU	BD 3					SKD 1	Ch12	T 30403	D 3
				1.2083	X 42 Cr 13	Z 40 C 14	X 41 Cr 13 KU						SUS 420 J 2			
				1.2341	X 6 CrMo 4											
				1.2363	X 100 CrMoV 5 1	Z 100 CDV 5	X 100 CrMoV 5 1 KU	BA 2					SKD 12	2260	T 30102	A 2
				1.2379	X 155 CrVMo 12 1	Z 160 CDV 12	X 155 CrVMo 12 1 KU	BD 2					SKD 11		T 30402	D 2
	1.2436	X 210 CrW 12		Z 200 CW 12	X 215 CrW 12 1 KU						SKD 2	2312				
	1.2601	X 165 CrMoV 12			X 165 CrMoW 12 KU							2310				
	1.2764	X 19 NiCrMo 4														
	1.2767	X 45 NiCrMo 4		Y 35 NCD 16	42 NiCrMo 15 7											
	1.2885	X 32 CrMoCoV 3 3 3		30 DCKV 28												
	3.2.5 high alloyed tempered	1.2316		X 36 CrMo 17		X 36 CrMo 16 1 KU										
		1.6356		X 2 NiCoMoTi 18 12 4												
		1.6358		X 2 NiCoMoTi 18 9 5												
	3.3 Tool steel for hot working	3.3.1 low alloyed up to 1200 N/mm ²	1.2311	40 CrMnMo 7												
			1.2738	40 CrMnNiMo 8												
			1.2744	57 NiCrMoV 7 7												
		3.3.2 low alloyed up to 1500 N/mm ²	1.2713	55 NiCrMoV 6	55 NCDV 7						SKT 4	5ChNM	T 61206	L 6		
		3.3.3 high alloyed annealed	1.2343	X 38 CrMoV 5 1	Z 38 CDV 5	X 37 CrMoV 5 1 KU	BH 11					SKD 6	4Ch5MFS	T 28811	H 11	
			1.2344	X 40 CrMoV 5 1	Z 40 CDV 5	X 40 CrMoV 5 1 KU	BH 13					SKD 61	2242	4Ch5MF1S	T 20813	H 13
			1.2365	X 32 CrMoV 3 3	32 DCV 28	30 CrMoV 12 27 KU	BH 10					SKD 7		3Ch3M3F	T 20810	H 10
			1.2367	X 38 CrMoV 5 3												
			1.2567	X 30 WCrV 5 3	Z 32 WCV 5	X 30 WCrV 5 3 KU						SKD 4				
			1.2581	X 30 WCrV 9 3	Z 30 WCV 9	X 30 WCrV 9 3 KU	BH 21					SKD 5		3Ch2W8F	T 20821	H 21
			1.2706	X 3 NiCrMo 18 8 5	E-Z 2 NKD 18										K 93120	
		3.3.4 high alloyed tempered	1.2709	X 2 NiCoMoTi 18 9 5	tempered											

Material main group	Material sub-group	Quality	StNr	DIN	AFNOR	UNI	BS	JIS	SS	GOST	UNS	USA			
3 Tool steel	3.4 High speed steel	3.4.1 general	1.3202	S 12-1-4-5							T 12015	T 15			
			1.3207	S 10-4-3-10	Z 130 WKCDV 10-10-04	HS 10-4-3-10	BT 42	SKH 57							
			1.3243	S 6-5-2-5	Z 85 WDKCV 06-05-05-	HS 6-5-2-5		SKH 55	2723	R6M5K5					
			1.3246	S 7-4-2-5	Z 110 WKCDV 07-05-04	HS 7-4-2-5							T 11341	M 41	
			1.3247	S 2-10-1-8	Z 110 DKCWW 09-08-04	HS 2-9-1-8	BM 42	SKH 51					T 11342	M 42	
			1.3249	S 2-9-2-8			BM 34						T 11333	M 33; M 34	
			1.3255	S 18-1-2-5	Z 80 WKCV 18-05-04-0	HS 18-1-1-5	BT 4	SKH 3					T 12004	T 4	
			1.3257	S 18-1-2-15											
			1.3265	S 18-1-2-10		HS 18-0-1-10	BT 5	SKH 4 A					T 12005	T 5	
			1.3302	S 12-1-4											
			1.3318	S 12-1-2											
			1.3333	S 3-3-2		HS 3-3-2									
			1.3343	S 6-5-2	Z 85 WDCV 06-05-04-0	HS 6-5-2	BM 2	SKH 9; SKH 51	2722	R6AM5	T 11302	M 2			
			1.3344	S 6-5-3	Z 120 WDCV 06-05-04-	HS 6-5-3	BM 4	SKH 52; SKH 53			T 11323	M 3 Cl. 2			
			1.3346	S 2-9-1	Z 85 DCWV 08-04-02-0	HS 1-8-1	BM 1			H41	T 11301	H 41; M 1			
			1.3348	S 2-9-2	Z 100 DCWV 09-04-02-	HS 2-9-2			2782		T 11307	M 7			
			1.3355	S 18-0-1	Z 80 WCV 18-04-01	HS 18-0-1	BT 1	SKH 2		R18	T 12001	T 1			
			3.5 Hardened tool steel	3.5.1 < 55 HRC 3.5.2 55 – 58 HRC 3.5.3 58 – 60 HRC 3.5.4 60 – 62 HRC 3.5.5 62 – 64 HRC	hardened										
	hardened														
	hardened														
hardened															
hardened															
4 Stainless steel, heat-resistant alloys	4.1 Stainless steel	4.1.1 ferritic	1.4000	X 6 Cr 13	Z 6 C 13	X 6 Cr 13	403 S 17	SUS 403	2301	08Ch13	S 40300	403			
			1.4002	X 6 CrAl 13	Z 6 CA 13	X 6 CrAl 13	405 S 17	SUS 405	2302		S 40500	405			
			1.4016	X 6 Cr 17	Z 8 C 17	X 8 Cr 17	430 S 15	SUS 430	2320	12Ch17	S 43000	430			
			1.4113	X 6 CrMo 17	Z 8 CD 17.01	X 8 CrMo 17	434 S 17	SUS 434	2325		S 43400	434			
			1.4313	X 5 CrNi 13 4	Z 5 CN 13.4	X 6 CrNi 13 04	425 C 11	SCS 5	2385			CA 6-NM			
			1.4510	X 6 CrTi 17	Z 8 CT 17	X 6 CrTi 17		SUS 430 LX		08Ch17T	S 43036	XM 8; 430 Ti			
			1.4511	X 8 CrNb 17	Z 8 CNb 17	X 6 CrNb 17		SUS 430 LX							
			1.4512	X 5 CrTi 12	Z 6 CT 12	X 6 CrTi 12	409 S 19	SUH 409			S 40900	409			
			4.1.2 martensitic	1.4006	X 10 Cr 13	Z 12 C 13	X 12 Cr 13	410 S 21	SUS 410	2302	12Ch13	S 41000	410; CA-15		
				1.4021	X 20 Cr 13	Z 20 C 13	X 20 Cr 13	420 S 37	SUS 420 J 1	2303	20Ch13	S 42000	420		
				1.4024	X 15 Cr 13	Z 13 C 13		420 S 29	SUS 410 J 1						
				1.4028	X 30 Cr 13	Z 30 C 13	X 30 Cr 13	420 S 45	SUS 420 J 2	2304	30Ch13				
				1.4031	X 38 Cr 13	Z 40 C 14	X 40 Cr 14		SUS 420 J 2	2304	40Ch13				
				1.4034	X 46 Cr 13	Z 40 C 14	X 40 Cr 14	420 S 45			40Ch13				
				1.4057	X 20 CrNi 17 2	Z 15 CN 16.02	X 16 CrNi 16	431 S 29	SUS 431	2321	20Ch17N2	S 43100	431		
		1.4108		X 100 CrMo 13											
		1.4109		X 65 CrMo 14											
		1.4112		X 90 CrMoV 18							S 44003				
		1.4113		X 6 CrMo 17	Z 8 CD 17.01	X 8 CrMo 17	434 S 17	SUS 434	2325		S 43400	434			
		1.4116		X 45 CrMoV 15											
		1.4125		X 105 CrMo 17	Z 100 CD 17	X 105 CrMo 17		SUS 440 C			S 44004	440 C			
		4.1.3 austenitic A5 < 40%		1.4311	X 2 CrNiN 18 10	Z 2 CN 18 .10	X 2 CrNiN 18 11	304 S 62	SUS 304 LN	2371		S 30453	304 LN		
				1.4401	X 5 CrNiMo 18 10	Z 6 CND 17.11	X 5 CrNiMo 17 12	316 S 16	SUS 316	2347		S 31600	316		
			1.4404	X 2 CrNiMo 17 13 2	Z 2 CND 17.12	X 2 CrNiMo 17 12	316 S 11	SUS 316 L	2348		S 31603	316 L			
			1.4406	X 2 CrNiMoN 17 12 2	Z 2 CND 17.12 Az	X 2 CrNiMoN 17 12	316 S 61	SUS 316 LN			S 31653	316 LN			
			1.4429	X 2 CrNiMoN 17 13 3	Z 2 CND 17.13 Az	X 2 CrNiMoN 17 13	316 S 62	SUS 316 LN	2375		S 31653	316 LN			
			1.4435	X 2 CrNiMo 18 14 3	Z 2 CND 17.13	X 2 CrNiMo 17 13	316 S 12	SCS 16; SUS 316 L	2353	03Ch17N14M2	S 31603	316 L			
			1.4436	X 5 CrNiMo 17 13 3	Z 6 CND 17.12	X 5 CrNiMo 17 13	316 S 16	SUS 316	2343		S 31600	316			

Technical information

Material table

F23



Material main group	Material sub-group	Quality	StNr	DIN	AFNOR	UNI	BS	JIS	SS	GOST	UNS	USA		
4 Stainless steel, heat-resistant alloys	4.1 Stainless steel	4.1.3 austenitic A5 < 40%	1.4438	X 2 CrNiMo 18 16 4	Z 2 CND 19.15	X 2 CrNiMo 18 15	317 S 12	SUS 317 L	2367		S 31703	317 L		
			1.4460	X 8 CrNiMo 27 5	Z 5 CND 27.05 Az			SUS 329 J 1	2324		S 32900	329		
			1.4462	X 2 CrNiMoN 22 5	Z 2 CND 22 5 Az							S 31803		
			1.4539	X 2 NiCrMoCu 25 20 5	Z 1 CNDU 25 20								N 08904	
			1.4541	X 6 CrNiTi 18 10	Z 6 CNT 18.10	X 6 CrNiTi 18 11	321 S 12	SUS 321	2337	12Ch18N10T	S 32100	321		
			1.4542	X 5 CrNiCuNb 17 14	Z 5 CNU 17.4				SCS 24; SUS 630			S 17400	630	
			1.4546	X 5 CrNiNb 18 10		X 6 CrNiNb 18 11	347 S 18					S 34800	348	
			1.4550	X 6 CrNiNb 18 10	Z 6 CNNb 18.10	X 6 CrNiNb 18 11	347 S 17	SUS 347	2338	08Ch18N12B	S 34700	347		
			1.4571	X 6 CrNiMoTi 17 12 2	Z 6 CNT 17.12	X 6 CrNiMoTi 17 12	320 S 31		2350	10Ch17N13M2T	S 31635	316 Ti		
			1.4580	X 6 CrNiMoNb 17 12 2	Z 6 CNDNb 17.12	X 6 CrNiMoNb 17 12	318 S 17			08Ch16N13M2B	S 31640	316 Cb		
		4.1.4 austenitic A5 > 40%	1.4301	X 5 CrNi 18 9	Z 6 CN 18.09	X 5 CrNi 18 10	304 S 15	SUS 304	2332; 2333	08Ch18N10	S 30400	304; 304 H		
			1.4303	X 5 CrNi 18 12	Z 8 CN 18.12	X 8 CrNi 19 10	305 S 19	SUS 305		06Ch18N11	S 30500	308; 305		
			1.4306	X 2 CrNi 19 11	Z 2 CN 18.10	X 2 CrNi 18 11	304 S 12	SCS 19	2352; 2333	03Ch18N11	S 30403	304 L		
			1.4310	X 12 CrNi 17 7	Z 12 CN 17.07	X 12 CrNi 17 07	301 S 21	SUS 301			S 30100	301		
			1.4573	X 10 CrNiMoTi 18 12		X 6 CrNiMoTi 17 13	320 S 33			10Ch17N13M3T	S 31635	316 Ti		
			1.4583	X 10 CrNiMoNb 18 12		X 6 CrNiMoNb 17 13						318		
			4.1.5 martensitic	1.4005	X 12 CrS 13	Z 12 CF 13	X 12 CrS 13	416 S 21	SUS 416	2380		S 41600	416	
				1.4104	X 12 CrMoS 17	Z 10 CF 17	X 10 CrS 17		SUS 430 F	2383		S 43020	430 F	
		4.1.6 austenitic A5 > 40%	1.4305	X 10 CrNiS 18 9	Z 10 CNF 18.09	X 10 CrNi 18 09	303 S 21	SUS 303	2346		S 30300	303		
			4.1.7 sulphured		sulphured									
	4.2 Heat-resistant alloys	4.2.1 Fe alloys	1.4718	X 45 CrSi 9 3	Z 45 CS 9	X 45 CrSi 8	401 S 45	SUH 1		40Ch9S2	S 65007	HNV 3		
			1.4724	X 10 CrAl 13	Z 10 C 13	X 10 CrAl 12	403 S 17			10Ch13SJ				
			1.4742	X 10 CrAl 18	Z 10 CAS 18	X 8 Cr 17	430 S 15	SUS 430; SUH21				430		
			1.4747	X 80 CrNiSi 20	Z 80 CSN 20.02	X 80 CrSiNi 20	443 S 65	SUH 4			S 65006	HNV 6		
			1.4762	X 10 CrAl 24	Z 10 CAS 24	X 16 Cr 26					S 44600	446		
			1.4828	X 15 CrNiSi 20 12	Z 15 CNS 20.12		309 S 24	SUH 309		20Ch20N14S2	S 30900	309		
			1.4841	X 15 CrNiSi 25 20	Z 15 CNS 25.20	X 16 CrNiSi 25 20		SUH 310		20Ch25N20S2	S 31000	314; 310		
			1.4845	X 12 CrNi 25 21	Z 12 CN 25.20	X 6 CrNi 26 20	310 S24	SUH 310; SUS 310 S	2361		S 31008	310 S		
			1.4864	X 12 NiCrSi 36 16	Z 12 NCS 37.18		NA 17	SUH 330			N 08330	330		
			1.4871	X 53 CrMnNiN 21 9	Z 52 CMN 21.09	X 53 CrMnNiN 21 9	349 S 54	SUH 35; SUH 36		55Ch20G9AN4	S 63008	EV 8		
			1.4873	X 45 CrNiW 18 9	Z 35 CNWS 20.09	X 45 CrNiW 18 9	331 S 40	SUH 31						
			1.4876	X 10 NiCrAlTi 33 20	Z 8 NC 32.21		NA 15 (H)	NCF 800				B 163		
			1.4878	X 12 CrNiTi 18 9	Z 6 CNT 18.12 (B)	X 6 CrNiTi 18 11	321 S 20	SUS 321	2337	12Ch18N10T		321		
			1.4923	X 22 CrMoV 12 1			762							
			1.4935	X 20 CrMoWV 12 1								S 42200		
			1.4943	X 4 NiCrTi 25 15	Z 6 NCTDV 25.15 B		HR 251; HR 52; HR 51	SUH 660						
			1.4945	X 6 CrNiWNb 16 16										
			1.4962	X 12 CrNiWTi 16 3										
			1.4980	X 5 NiCrTi 26 15								S66286		
			4.2.2 Ni alloys, non hardened	1.4876	X 10 NiCrAlTi 32 20	Incoloy 800								
		2.4360		NiCu30Fe	Monel 400									
		2.4375		NiCu30Al	Monel K 500									
		2.4603		NiCr30FeMo	Hastelloy X									
		2.4617			Hastelloy B-2									
		2.4640		NiCr15Fe	Inconel 600									
		2.4668		NiCr19Fe18Nb5Mg	Inconel 718									
		2.4812			Hastelloy C									
2.4816		NiCr15Fe		Inconel 600		NA 14	NCF 600				N 06600			
2.4856	NiCr22Mo9Nb	Inconel 625												
2.4858	NiCr21Mo			NA 16	NCF 825				N 08825					
2.4983		Udimet 500												

Material main group	Material sub-group	Quality	StNr	DIN	AFNOR	UNI	BS	JIS	SS	GOST	UNS	USA		
4 Stainless steel, heat-resistant alloys	4.2 Heat-resistant alloys	4.2.3 Ni alloys, hardened	2.4630	NiCr20Ti	Nimonic 75		HR 5							
			2.4631	NiCr20TiAl	Nimonic 80 A		HR 401; 601	NCF 80 A			N 07080			
			2.4632	NiCr20Co18Ti	Nimonic 90									
			2.4634	NiCo20Cr15MoAlTi	Nimonic 105									
			2.4662	NiCr13Mo6Ti3	Nimonic 901									
			2.4670		Nimocast 713									
			2.4674		Nimocast PK 24									
			2.4951	NiCr20Ti	Nimonic 75				HR 5					
			2.4952	NiCr20TiAl	Nimonic 80 A									
			2.4969	NiCr20Co18Ti	Nimonic 90									
			2.4973	NiCr19Co11MoTi										
		2.6554		Waspaloy										
		4.2.4 Co alloys	2.4711	CoCr20Ni15Mo										
			2.4964	CoCr20W15Ni										
			2.4979	CoCr28MoNi										
			2.4989	CoCr20NiW										
5 Cast steel	5.1 Conventional cast steel	5.1.1 non alloyed	1.0420	GS-38										
			1.0446	GS-45										
			1.0552	GS-52										
			1.0558	GS-60										
			1.0619	GS-C 25										
			1.1142	GS-Ck 16										
			1.1155	GS-Ck 25										
			1.1191	GS-Ck 45										
			5.1.2 low alloyed	1.1118	GS-24 Mn 6									
				1.1120	GS-20 Mn 5									
				1.1131	GS-16 Mn 5									
				1.1136	GS-24 Mn 4									
				1.1138	GS-21 Mn 5									
				1.1159	GS-46 Mn4									
				1.1165	GS-30 Mn 5									
				1.1167	GS-36 Mn 5									
				1.1168	GS-40 Mn 5									
				1.2311	GS-40 CrMnMo 7									
		1.2323		GS-48 CrMoV 6 7										
		1.2713		GS-55 NiCrMoV 6										
		1.2728		GS-20 MoNi 33 13										
		1.2887		GS-34 CoCrMoV 19 12										
		1.5015		GS-8 Mn 7										
		1.5120		GS-38 MnSi 4										
		1.5121		GS-46 MnSi 4										
		1.5122		GS-37 MnSi 5										
		1.5418		GS-20 MnMo 5 3										
		1.5419		GS-22 Mo 4										
		1.5430		GS-8 MnMo 7 4										
		1.5431		GS-12 MnMo 7 4										
		1.5475		GS-20 MnNb 5										
		1.5485		GS-20 MnNiTi 5 3										
		1.5621	GS-10 Ni 6											
		1.5633	GS-24 Ni 8											
		1.5638	GS-10 Ni 14											
		1.5681	GS-10 Ni 19											
		1.5919	GS-15 CrNi 6											

Technical information

Material table

F25



Material main group	Material sub-group	Quality	StNr	DIN	AFNOR	UNI	BS	JIS	SS	GOST	UNS	USA		
5 Cast steel	5.1 Conventional cast steel	5.1.2 low alloyed	1.6219	GS-22 MnNi 5										
			1.6221	GS-13 MnNi 6 4										
			1.6309	GS-20 MnMoNi 5 5										
			1.6511	GS-36 CrNiMo 4										
			1.6515	GS-25 CrNiMo 4										
			1.6552	GS-24 CrNiMo 3 2 5										
			1.6570	GS-30 NiCrMo 8 5										
			1.6582	GS-34 CrNiMo 6										
			1.6740	GS-33 NiCrMo 7 4 4										
			1.6741	GS-38 NiCrMo 8 4 4										
			1.6748	GS-40 NiCrMo 6 5 6										
			1.6750	GS-20 NiCrMo 3 7										
			1.6759	GS-18 NiMoCr 3 6										
			1.6760	GS-22 NiMoCr 5 6										
			1.6779	GS-14 NiCrMo 10 6										
			1.6781	GS-18 NiCrMo 12 6										
			1.6783	GS-19 NiCrMo 12 6										
			1.6916	GS-12 MnNiCrMo 5 3										
			1.7131	GS-16 MnCr 5										
			1.7147	GS-20 MnCr 5										
			1.7218	GS-25 CrMo 4										
			1.7219	GS-26 CrMo 4										
			1.7220	GS-34 CrMo 4										
			1.7225	GS-42 CrMo 4										
			1.7228	GS-50 CrMo 4										
			1.7341	GS-34 CrMo 4 4										
			1.7354	GS-22 CrMo 5 4										
			1.7354	GS-17 CrMnMo 5 5										
			1.7357	GS-17 CrMo 5 5										
			1.7363	GS-12 CrMo 19 5										
			1.7377	GS-17 CrMo 9 10										
			1.7379	GS-18 CrMo 9 10										
		1.7380	GS-12 CrMo 9 10											
		1.7382	GS-19 CrMo 9 10											
		1.7706	GS-17 CrMoV 5 11											
		1.7725	GS-30 CrMoV 6 4											
		1.7755	GS-35 CrMoV 10 4											
		1.7756	GS-36 CrMoV 10 4											
		1.7903	GS-18 MnCrMo 6 3											
		1.7906	GS-19 MnCrMo 6 3											
		1.7909	GS-20 MnCrMo 6 3											
		1.8159	GS-50 CrV 4											
		5.1.3 high alloyed		1.2201	G-X 165 CrV 12									
				1.2343	G-X 38 CrMoV 5 1	Z 38 CDV 5								
1.2363	G-X 100 CrMoV 5 1			Z 100 CDV 5										
1.2365	G-X 32 CrMoV 3 3			32 DCV 28										
1.2367	G-X 40 CrMoV 5 3			Z 40 CDV 5										
1.2392	G-X 28 CrMoV 5 1													
1.2601	G-X 165 CrMoV 12													
1.2606	G-X 37 CrMoW 5 1													
1.2880	G-X 165 CrCoMo 12													
1.3401	G-X 120 Mn 12			Z 120 M 12	XG 120 Mn 12	Z 120 M 12	SCMnH 1		110G13L		A 128 (A)			
1.3966	G-X 25 MnCrNi 8 8 6													

Material main group	Material sub-group	Quality	StNr	DIN	AFNOR	UNI	BS	JIS	SS	GOST	UNS	USA		
5 Cast steel	5.1 Conventional cast steel	5.1.3 high alloyed	1.4710	G-X 30 CrSi 6										
			1.4718	G-X 45 CrSi 9 3										
			1.5662	G-X 8 Ni 9										
			1.6351	G-X 2 NiCoMoTi 17 10										
			1.7389	G-X 12 CrMo 10 1										
5.2 Stainless cast steel	5.2.1 ferritic / martensitic	1.4001	G-X 7 Cr 13	Z 8 C 13 FF										
		1.4006	G-X 10 Cr 13	Z 10 C 13										
		1.4008	G-X 8 CrNi 13	Z 12 CN 13 M										
		1.4027	G-X 20 Cr 14	Z 20 C 13 M		420 C 29	SCS 2		20Ch13L					
		1.4034	G-X 46 Cr 13	Z 40 C 14										
		1.4059	G-X 22 CrNi 17											
		1.4085	G-X 70 Cr 29											
		1.4086	G-X 120 Cr 29											
		1.4107	G-X 8 CrNi 12											
		1.4120	G-X 20 CrMo 13											
		1.4122	G-X 35 CrMo 17											
		1.4136	G-X 70 CrMo 29 2											
		1.4138	G-X 120 CrMo 29 2											
		1.4313	G-X 5 CrNi 13 4											
		1.4339	G-X 32 CrNi 28 10											
		1.4340	G-X 40 CrNi 27 4											
		1.4405	G-X 5 CrNiMo 16 5											
		1.4407	G-X 5 CrNiMo 13 4											
		1.4414	G-X 4 CrNiMo 13 4											
		1.4464	G-X 40 CrNiMo 27 5											
		1.4540	G-X 4 CrNiCuNb 16 4											
		1.4729	G-X 40 CrSi 13											
		1.4740	G-X 40 CrSi 17											
		1.4743	G-X 160 CrSi 18											
		1.4745	G-X 40 CrSi 23											
		1.4761	G-X 120 CrSi 23											
		1.4776	G-X 40 CrSi 29											
		1.4777	G-X 130 CrSi 29											
		1.4809	G-X 40 CrNi 23 14											
		1.4820	G-X 12 CrNi 26 5											
		1.4822	G-X 40 CrNi 24 5											
		1.4823	G-X 40 CrNiSi 27 4											
		1.4825	G-X 25 CrNiSi 18 9											
		1.4826	G-X 40 CrNiSi 22 9											
		1.4832	G-X 25 CrNiSi 20 14											
		1.4837	G-X 40 CrNiSi 25 12											
		1.4840	G-X 15 CrNi 25 20											
		1.4848	G-X 40 CrNiSi 25 20											
		1.4849	G-X 40 NiCrSiNb 38 1											
		1.4852	G-X 40 NiCrNb 35 25											
		1.4855	G-X 30 CrNiSiNb 24 2											
		1.4857	G-X 40 NiCrSi 35 25											
		1.4859	G-X 10 NiCrNb 32 20											
1.4865	G-X 40 NiCrSi 38 18					GX 50 NiCr 39 19	330 C 40	SCH 15; SCH 16						
1.4868	G-X 50 CrNi 30 30													
1.4873	G-X 45 CrNiW 18 9													
1.4928	G-X 12 CrNiMoCoVN 12													
1.4930	G-X 14 CrCoMo 13 10													

Technical information

Material table

F27



Material main group	Material sub-group	Quality	StNr	DIN	AFNOR	UNI	BS	JIS	SS	GOST	UNS	USA			
5 Cast steel	5.2 Stainless cast steel	5.2.1 ferritic / martensitic	1.4931	G-X 22 CrMoV 12 1											
			1.4957	G-X 15 CrNiCo 21 20											
			1.4968	G-X 7 CrNiNb 16 13											
			1.4988	G-X 8 CrNiMoVNb 16 1											
			1.6982	G-X 3 CrNi 13 4											
			5.2.2 austenitic	1.3941	G-X 4 CrNi 18 13										
				1.3944	G-X 5 CrNi 18 11										
				1.3951	G-X 4 CrNiMoN 22 15										
				1.3952	G-X 4 CrNiMoN 18 14										
				1.3953	G-X 2 CrNiMo 18 15										
		1.3955		G-X 12 CrNi 18 11											
		1.3959		G-X 10 CrNiNb 16 13											
		1.3964		G-X 4 CrNiMnMoN 19 1											
		1.4306		G-X 2 CrNi 18 9											
		1.4308		G-X 6 CrNi 18 9	Z 6 CN 18.10 M		304 C 15	SCS 13	2333	07Ch18N9L				CF-8	
		1.4312		G-X 10 CrNi 18 8											
		1.4347		G-X 8 CrNi 26 7											
		1.4404		G-X 2 CrNiMo 18 10											
		1.4408		G-X 6 CrNiMo 18 10											
		1.4410		G-X 10 CrNiMo 18 9											
		1.4437		G-X 6 CrNiMo 18 12											
		1.4439		G-X 3 CrNiMo 17 13 5											
		1.4446		G-X 2 CrNiMo 17 13 4											
		1.4448		G-X 6 CrNiMo 17 13											
		1.4463		G-X 6 CrNiMo 24 8 2											
		1.4465		G-X 2 CrNiMoN 25 25											
		1.4500		G-X 7 NiCrMoCuNb 25											
		1.4531		G-X 2 NiCrMoCuN 20 1											
		1.4536		G-X 2 NiCrMoCuN 25 2											
		1.4552	G-X 5 CrNiNb 18 9												
		1.4580	G-X 10 CrNiMoNb 18 1												
		1.4581	G-X 5 CrNiMoNb 18 10	Z 4 CNDNb 18.12 M		GX 6 CrMoNb 20 11	318 C 17	SCS 22							
		1.4585	G-X 7 CrNiMoCuNb 18												
		1.4815	G-X 8 CrNi 19 10												
1.4927	G-X 5 CrNi 22 10														
1.6901	G-X 8 CrNi 18 10														
1.6902	G-X 6 CrNi 18 10														
1.6905	G-X 5 CrNiNb 18 10														
6 Cast iron	6.1 Cast iron with lamellar graphite	6.1.1 non alloyed up to 180 HB	6.010	GG-10	F1 10 D	G 10		FC 10	01 10-00	Sc 10		A48-20 B			
			6.015	GG-15	F1 15 D	G 15	Grade 150	FC 15	01 15-00	Sc 15		A48-25 B			
			6.020	GG-20	F1 20 D	G 20	Grade 220	FC 20	01 20-00	Sc 20		A48-30 B			
			6.025	GG-25	F1 25 D	G 25	Grade 260	FC 25	01 25-00	Sc 25		A48-40 B			
			6.030	GG-30	F1 30 D	G 30	Grade 300	FC 30	01 30-00	Sc 30		A48-45 B			
			6.035	GG-35	F1 35 D	G 35	Grade 350	FC 35	01 35-00	Sc 35		A48-50 B			
		6.040	GG-40	F1 40 D			Grade 400		01 40-00	Sc 40		A48-60 B			
		6.1.2 non alloyed above 180 HB	6.652	GGL-NiMn 13 7	L- NM 13 7		L-NiMn 13 7								
			6.655	GGL-NiCuCr 15 6 2	L-NUC 15 6 2		L-NiCuCr 15 6 2							A 436 Type 1	
			6.656	GGL-NiCuCr 15 6 3	L-NUC 15 6 3		L-NiCuCr 15 6 3							A 436 Type 1b	
			6.660	GGL-NiCr 20 2	L-NC 20 2		L-NiCr 20 2			05 23-00				A 436 Type 2	
			6.661	GGL-NiCr 20 3	L-NC 20 3		L-NiCr 20 3							A 436 Type 2b	
			6.667	GGL-NiSiCr 20 5 3	L-NSC 20 5 3		L-NiSiCr 20 5 3								
			6.667	GGL-NiCr 30 3	L-NC 30 3		L-NiCr 30 3							A 436 Type 3	
6.680	GGL-NiSiCr 30 5 5		L-NSC 30 5 5		L-NiSiCr 30 5 5							A 436 Type 4			
6 Cast iron	6.1 Cast iron with lamellar graphite	6.1.3 alloyed	6.010	GG-10	F1 10 D	G 10		FC 10	01 10-00	Sc 10		A48-20 B			
			6.015	GG-15	F1 15 D	G 15	Grade 150	FC 15	01 15-00	Sc 15		A48-25 B			
			6.020	GG-20	F1 20 D	G 20	Grade 220	FC 20	01 20-00	Sc 20		A48-30 B			
			6.025	GG-25	F1 25 D	G 25	Grade 260	FC 25	01 25-00	Sc 25		A48-40 B			
			6.030	GG-30	F1 30 D	G 30	Grade 300	FC 30	01 30-00	Sc 30		A48-45 B			
			6.035	GG-35	F1 35 D	G 35	Grade 350	FC 35	01 35-00	Sc 35		A48-50 B			
			6.040	GG-40	F1 40 D			Grade 400		01 40-00	Sc 40		A48-60 B		
			6.652	GGL-NiMn 13 7	L- NM 13 7		L-NiMn 13 7								
			6.655	GGL-NiCuCr 15 6 2	L-NUC 15 6 2		L-NiCuCr 15 6 2							A 436 Type 1	
			6.656	GGL-NiCuCr 15 6 3	L-NUC 15 6 3		L-NiCuCr 15 6 3							A 436 Type 1b	
			6.660	GGL-NiCr 20 2	L-NC 20 2		L-NiCr 20 2			05 23-00				A 436 Type 2	
			6.661	GGL-NiCr 20 3	L-NC 20 3		L-NiCr 20 3							A 436 Type 2b	
			6.667	GGL-NiSiCr 20 5 3	L-NSC 20 5 3		L-NiSiCr 20 5 3								
			6.667	GGL-NiCr 30 3	L-NC 30 3		L-NiCr 30 3							A 436 Type 3	
6.680	GGL-NiSiCr 30 5 5	L-NSC 30 5 5		L-NiSiCr 30 5 5							A 436 Type 4				

Material main group	Material sub-group	Quality	StNr	DIN	AFNOR	UNI	BS	JIS	SS	GOST	UNS	USA		
6 Cast iron	6.1 Cast iron with lamellar graphite	6.1.4 high alloyed	0.9620	G-X 260 NiCr 4 2			Grade 2 A		0512-00			A 532 I B NiCr-LC		
			0.9625	G-X 330 NiCr 4 2			Grade 2 B		0513-00			A 532 I A NiCr-HC		
			0.9630	G-X 300 CrNiSi 9 5 2				Grade 2 C; D; E		0457-00			A 532 I D Ni-HCr	
			0.9635	G-X 330 CrMo 15 3				Grade 3 A; B						A 532 II C 15% CrMo-
			0.9640	G-X 300 CrMoNi 15 2				Grade 3 A; B						
			0.9645	G-X 260 CrMoNi 20 2				Grade 3 C						A 532 II D 20% CrMo-
			0.9650	G-X 260 Cr 27				Grade 3 D			0466-00			A 532 III A 25% Cr
				0.9655	G-X 300 CrMo 27 1			Grade 3 E					A 532 III A 25% Cr	
		6.2 Spheroidal cast iron	6.2.1 non alloyed up to 180 HB	0.7033	GGG-35.3									
	0.7040			GGG-40	FGS 400-12	GS 400-12	SNG 420/12	FCD 40	0717-02	VC 42-12			60-40-18	
	0.7043			GGG-40.3	FGS 370-17	GSO 42/17	SNG 370/17		0717-15	VC 42-12				
				6.2.2 non alloyed above 180 HB	0.7050	GGG-50	FGS 500-7	GS 500/7	SNG 500/7	FCD 50	0727-02	VC 50-2		65-45-12
	0.7060		GGG-60		FGS 600-3	GS 600/3	SNG 600/3	FCD 60	0732-03	VC 60-2			80-55-06	
	0.7070		GGG-70		FGS 700-2	GS 700-2	SNG 700/2	FCD 70	0737-01	VC 70-2			100-70-03	
	0.7080		GGG-80		FGS 800-2	GS 800-2	SNG 800/2			VC 80-2			120-90-02	
				6.2.3 alloyed	0.7652	GGG-NiMn 13 7	S-NM 13 7		S-NiMn 13 7					
	0.7660		GGG-NiCr 20 2		S-NC 20 2		S-NiCr 20 2							A 439 Type D-2
	0.7661		GGG-NiCr 20 3		S-NC 20 3		S-NiCr 20 3							A 439 Type D-2B
	0.7665		GGG-NiSiCr 20 5 2		S-NSC 20 5 2		S-NiSiCr 20 5 2							
	0.7670		GGG-Ni 22		S-N 22		S-Ni 22							A 439 Type D-2C
	0.7673		GGG-NiMn 23 4		S-NM 23 4		S-NiMn 23 4							A 439 Type D-2M
	0.7676	GGG-NiCr 30 3	S-NC 30 3			S-NiCr 30 3							A 439 Type D-3	
	0.7677	GGG-NiCr 30 1	S-NC 30 1			S-NiCr 30 1							A 439 Type D-3A	
	0.7680	GGG-NiSiCr 30 5 5	S-NSC 30 5 5		S-NiSiCr 30 5 5							A 439 Type D-4		
	0.7683	GGG-Ni 35	S-N 35		S-Ni 35							A 439 Type D-5		
	0.7685	GGG-NiCr 35 3	S-NC 35 3		S-NiCr 35 3							A 439 Type D-5B		
		6.3 GTW (white malleable cast iron)	6.3.1 up to 180 HB	0.8035	GTW-35-04									
	0.8040			GTW-40-05										
	0.8045			GTW-45-07										
			6.3.2 above 180 HB	0.8055	GTW-55									
	0.8065	GTW-65												
		6.4 GTS (black malleable cast iron)	6.4.1 up to 180 HB	0.8135	GTS-35-10	MN 35-10		B 340/12						
	0.8145			GTS-45-06				P 440/7						
	0.8155		GTS-55-04	MP 50-5			P 510/4							
	0.8165		GTS-65-02	MP 60-3			P 570/3							
	0.8170		GTS-70-02	IP 70-2			P 690/2							
7 Non-ferrous metals	7.1 Aluminium	7.1.1 non alloyed	3.0205	Al99										
			3.0255	Al99.5	1050 A									
			3.0275	Al99.7										
			3.0285	Al99.8										
			3.0305	Al99.9										
			3.0505	AlMn0.5Mg0.5										
			3.0515	AlMn1										
			3.0517	AlMnCu										
		3.0525	AlMn1Mg0.5	3005										
		3.0526	AlMn1Mg1											
		3.0915	AlFeSi											
		3.3307	Al99.85Mg0.5											
		3.3308	Al99.5Mg0.5											
		3.3315	AlMg1	5005										
		3.3316	AlMg1.5											
		3.3317	Al99.85Mg1											

Technical information

Material table

F29



Material main group	Material sub-group	Quality	StNr	DIN	AFNOR	UNI	BS	JIS	SS	GOST	UNS	USA	
7 Non-ferrous metals	7.1 Aluminium	7.1.2 aluminium wrought alloys, non hardened	3.3318	Al99.9Mg1									
			3.3326	AlMg1.8									
			3.3345	AlMg4.5									
			3.3523	AlMg2.5									
			3.3525	AlMg2Mn0.3									
			3.3527	AlMg2Mn0.8									
			3.3535	AlMg3	5754								
			3.3537	AlMg2.7Mn									
			3.3545	AlMg4Mn	5086								
			3.3547	AlMg4.5Mn	5087								
			3.3549	AlMg5Mn									
		3.3555	AlMg5	5056 A									
		3.0506	AlMn0.6										
		3.0615	AlMgSiPb										
		3.1255	AlCuSiMn	2014									
		3.1305	AlCu2.5Mg0.5										
		3.1325	AlCuMg1	2017 A									
		3.1355	AlCuMg2	2024									
		3.1645	AlCuMgPb	2030									
		3.1655	AlCuBiPb	2011									
		3.2307	Al99.85MgSi										
		3.2315	AlMgSi1	6082									
		3.3206	AlMgSi0.5	6060									
		3.3208	Al99.9MgSi										
		3.3210	AlMgSi0.7	6005 A									
		3.3211	AlMg1SiCu	6061									
		3.4335	AlZn4.5Mg1	7020									
		3.4337	Al99.8ZnMg										
		3.4345	AlZnMgCu0.5										
		3.4365	AlZnMgCu1.5	7075									
		3.1371	G-AlCu4TiMg										
		3.1841	G-AlCu4Ti										
		3.2134	G-AlSi5Cu1Mg										
	3.3241	G-AlMg3Si											
	3.3261	G-AlMg5Si											
	3.3292	GD-AlMg9											
	3.3541	G-AlMg3											
	3.3543	G-AlMg3(Cu)											
	3.3561	G-AlMg5											
	3.3591	G-AlMg10											
	3.2151	G-AlSi6Cu4											
	3.2161	G-AlSi8Cu3											
	3.2341	G-AlSi5Mg											
	3.2371	G-AlSi7Mg											
3.2373	G-AlSi9Mg												
3.2381	G-AlSi10Mg												
3.2383	G-AlSi10Mg(Cu)												
3.2581	G-AlSi12												
3.2583	G-AlSi12(Cu)												
		7.1.6 aluminium cast alloys above 12% Si		G-AlSi18									
	7.2 Magnesium	7.2.1 wrought alloys	3.5200	MgMn2									
			3.5312	MgAl3Zn									

Material main group	Material sub-group	Quality	StNr	DIN	AFNOR	UNI	BS	JIS	SS	GOST	UNS	USA		
7 Non-ferrous metals	7.2 Magnesium	7.2.1 wrought alloys	3.5612	MgAl6Zn										
			3.5812	MgAl8Zn										
		7.2.2 cast alloys	3.5101	G-MgZn4SE1Zr1										
			3.5102	G-MgZn5Th2Zr1										
			3.5103	G-MgSE3Zn2Zr1										
			3.5105	G-MgTh3Zn2Zr1										
			3.5106	G-MgAg3Se2Zr1										
			3.5470	GD-MgAl4Si1										
			3.5612	GD-MgAl6Zn1										
			3.5662	G-MgAl6										
			3.5812	G-MgAl8Zn1										
			3.5912	G-MgAl9Zn1										
		7.3 Copper	7.3.1 non alloyed	2.0040	OF-Cu									
	2.0060			E-Cu57										
	2.0065			E-Cu58										
	2.0070			SE-Cu										
	2.0076			SW-Cu										
	2.0090			SF-Cu										
	7.3.2 wrought alloys, non hardened		2.0205	CuZn0.5										
			2.1160	CuPb1P										
			2.1191	CuAg0.1P										
			2.1203	CuAg0.1										
			2.1265	CuCd0.5										
			2.1266	CuCd1										
			2.1310	CuFe2P										
			2.1322	CuMg0.4										
			2.1323	CuMg0.7										
			2.1356	CuMn3										
			2.1363	CuMn2										
			2.1366	CuMn5										
			2.1491	CuAsP										
			2.1498	CuSP										
			2.1522	CuSuMnF34										
			2.1522	CuSi2Mn										
			2.1525	CuSi3Mn										
			2.1546	CuTeP										
	7.3.3 wrought alloys, hardened		2.0850	CuNi2Be										
			2.0853	CuNi1.5Si										
			2.0855	CuNi2Si										
			2.0857	CuNi3Si										
			2.1245	CuBe1.7										
			2.1247	CuBe2										
			2.1248	CuBe2Pb										
			2.1285	CuCo2Be										
			2.1293	CuCrZr										
			2.1580	CuZr										
	7.3.4 CuNi alloys	2.0830	CuNi25											
2.0842		CuNi44Mn1												
2.0872		CuNi10Fe1Mn												
2.0875		CuNi9Sn2												
2.0882		CuNi30Mn1Fe												
2.0883		CuNi30Fe2Mn2												

Technical information

Material table

F31



Material main group	Material sub-group	Quality	StNr	DIN	AFNOR	UNI	BS	JIS	SS	GOST	UNS	USA			
7 Non-ferrous metals	7.3 Copper	7.3.5 CuNiZn alloys, long-chipping	2.0730	CuNi12Zn24											
			2.0740	CuNi18Zn20											
			2.0742	CuNi18Zn27											
		7.3.6 CuNiZn alloys, short-chipping	2.0771	CuNi7Zn39Mn5Pb3											
			2.0780	CuNi12Zn30Pb1											
			2.0790	CuNi18Zn19Pb1											
	7.4 CuZn (brass)	7.4.1 long-chipping	2.0220	CuZn5											
			2.0230	CuZn10											
			2.0240	CuZn15											
			2.0250	CuZn20											
			2.0261	CuZn28											
			2.0265	CuZn30											
			2.0280	CuZn33											
			2.0321	CuZn37											
			2.0332	CuZn37Pb0.5											
			2.0335	CuZn36											
			2.0360	CuZn40											
			2.0372	CuZn39Pb0.5											
			7.4.2 short-chipping	2.0331	CuZn36Pb1.5										
				2.0371	CuZn38Pb1.5										
				2.0375	CuZn36Pb3										
				2.0380	CuZn39Pb2										
				2.0401	CuZn39Pb3										
				2.0402	CuZn40Pb2										
				2.0410	CuZn44Pb2										
			2.0460	CuZn20Al2											
		2.0470	CuZn28Sn1												
		2.0490	CuZn31Si1												
		2.0500	CuZn23Al6Mn4Fe3												
		2.0510	CuZn37Al1												
		2.0525	CuZn38SnAl												
		2.0530	CuZn38Sn1												
		2.0540	CuZn35Ni2												
	2.0550	CuZn40Al2													
	2.0561	CuZn40Al1													
	2.0572	CuZn40Mn1													
	2.0580	CuZn40Mn1Pb													
	7.5 CuSn (bronze)	7.5.1 long-chipping	2.1016	CuSn4											
			2.1020	CuSn6											
			2.1030	CuSn8											
			2.1080	CuSn6Zn6											
		7.5.2 short-chipping	2.1086	G-CuSn10Zn											
			2.1093	G-CuSn6ZnNi											
2.1096	G-CuSn5ZnPb														
7.6 CuAlFe (Ampco)	7.6.1 long-chipping	2.0918	CuAl5As												
		2.0920	CuAl8												
		2.0932	CuAl8Fe3												
		2.0936	CuAl10Fe3Mn2												
		2.0960	CuAl9Mn2												
		2.0966	CuAl10Ni5Fe4												
		2.0971	CuAl9Ni3Fe2												
		2.0978	CuAl11Ni6Fe5												
		Ampco 12	CuAl9Fe3												

Material main group	Material sub-group	Quality	SINr	DIN	AFNOR	UNI	BS	JIS	SS	GOST	UNS	USA		
7 Non-ferrous metals	7.6 CuAlFe (Ampco)	7.6.1 long-chipping	Ampco 16	CuAl10Fe3										
			Ampco 18	CuAl10.5Fe3.5										
			Ampco 20	CuAl11Fe4										
			Ampco 21	CuAl13Fe4.5										
			Ampco 22	CuAl14Fe5										
			Ampco 25	Zn										
			Ampco 26	Zn										
			Ampco 45	CuAl10Fe2.5Ni5Mn1.5										
			Ampco 483	CuAl9Fe4Ni4.5Mn1										
			Ampco 8	CuAl6.5Fe2.5Sn										
	Ampco M-4	CuAl10.5Fe4Ni5Mn3.5												
		7.7 Nickel	7.7.1 non alloyed	2.1504	NiAlBz									
	2.4042			Ni99CSi										
	2.4060			Ni99.6										
	2.4062			Ni99.4Fe										
		7.8 Titanium	7.8.1 non alloyed	3.7024	Ti99.5									
	3.7034			Ti99.7										
		7.8.2 alloyed, soft annealed	7.8.2 alloyed, soft annealed	3.7055	Ti99.4									
	3.7064			Ti99.2										
	3.7114			TiAl5Sn2										
	3.7124			TiCu2										
	3.7144			TiAl6Sn2Zr4Mo2										
	3.7154			TiAl6Zr5										
	3.7165			TiAl6V4	T-A 6 V				TA 10 bis TA 13				R 56400	
	3.7174			TiAl6V6Sn2										
	3.7184	TiAl4Mo4Sn2						TA 45 bis TA 51						
	8 Plastics	8.1 Thermoplastics	8.1.1 polyethylene	PE	Baylon	Lacqtène	Alkathene	Eraclene	Mirason				Alathon	
				PE	Dekalen	Natène	Carlona	Fertene	Novatec				Bakelite	
				PE	Ertalen		Escorene	Rumiten	Rexlon				Chemplex	
				PE	Hostalen				Sholex				Dylan	
				PE	Lupolen				Sumikathene				Fortiflex	
				PE	Supralen				Suntec				Marlex	
PE				Symalen				Staflene				Microthene		
PE				Vestolen				Yukalon				Paxon		
PE												Petrothene		
PE												Poly-Eth		
PE											Rigidex			
PE											Rotothene			
8.1.2 polypropylene			PP	Daplen	Eltex P	Carlona P	Kastilen	Noblene					Pro-fax	
			PP	Hostalen PP	Lacqtène P	Propathene	Moplen	Poly-Pro					Rexene	
			PP	Luparen	Napryl	Procom		Sho-Allomer					Tenite	
			PP	Novolen		Propyply								
			PP	Symalen PP		Propafoil								
			PP	Vestolen PP										
8.1.3 polyvinyl chloride			PVC	Coroplast	Ekavyl	Breon	Raivinil	Nipeon	Pevikon				Dalvin	
			PVC	Hostalit,		Carina	Sicron	Nipolit					Geon	
	PVC	Mipolam		Corvic	Vipla	Vinika					Kohinor			
	PVC	Opalon		Scon	Viplast	Vinichlon					Marvinol			
	PVC	Rhodopas		Shell PVC							Plovic			
	PVC	Soflex		Welvic							Vygen			

Technical information

Material table

F33



Material main group	Material sub-group	Quality	StNr	DIN	AFNOR	UNI	BS	JIS	SS	GOST	UNS	USA			
8 Plastics	8.1 Thermoplastics	8.1.3 polyvinyl chloride	PVC	Solvec											
			PVC	Supradur											
			PVC	Trosiplast											
			PVC	Trovidur											
			PVC	Vestolit											
			PVC	Vinidur											
			PVC	Vinnol											
			PVC	Vinoflex											
		PVC	Vinylite												
			8.1.4 polystyrene	PS	Hostyron	Afcolène	Lustrex	Edistir	Diarex					Carinex	
		PS		Lorkalen	Lacqrene		Lastirol	Esbrite						Dylene	
		PS		Polystyrol	Gédex		Restirol							Styron	
		PS		Styropor											Toporex
		PS		Trolitul											
			8.1.5 polymethyl methacrylate	PMMA	Acrylglas	Altulite	Diakon	Lacrilix	Delpet					Lucite	
		PMMA		Daglas		Perspex	Vedril	Shinkolite						Oroglas	
		PMMA		Degalan				Sumipex						Swedcast	
		PMMA		Dewoglas											
		PMMA		Plexidur											
		PMMA		Plexiglas											
			8.1.6 Polytetrafluorethylene	PTFE	Hostaflon	Soreflon	Fluon		Neoflon					Halon	
		PTFE												Teflon	
			8.1.7 polyamide	PA	Akulon	Orgamide	Maranyl	Latamid	Amilan					Amidel	
		PA		Durethan	Rilsan	Verton	Nivionplast	Leona						Capron	
		PA		Faberyl	Technyl		Renyl	Toray						Fosta Nylon	
		PA		Grilamid			Sniamid	Torayca						Minlon	
		PA		Gnilon			Vydyne							Plaskon	
		PA		Nylon											
		PA		Trogamid											
		PA		Ultramid											
		PA	Vestamid												
			8.1.8 polycarbonate	PC	Makralon	Orgalan		Sinvet	Jupilon					Merlon	
		PC		Nuclon					Novarex					Lexan	
	PC	Plastocarbon							Panlite						
		8.1.9 polyamide, thermoplastic	PI		Kerimel								Torlon		
	PI				Kinel								Ultem		
	PI				Nolimid									PI 2080	
		8.2 Thermosetting plastics	8.2.1 phenol formaldehyde	PF	Alberit			Fenochem					Biralit		
	PF			Bakelit				Formolo						Biratex	
	PF			Bulitol				Moldesile						Birax	
	PF			Durax				Vegetalite							
	PF			Durophen											
PF	Faturan														
PF	Geax														
PF	Harex														
PF	Luphen														
PF	Pertinax														
PF	Resinol														
PF	Supraplast														
PF	Trolitan														
PF	Trolitax														

Material main group	Material sub-group	Quality	StNr	DIN	AFNOR	UNI	BS	JIS	SS	GOST	UNS	USA		
8 Plastics	8.2 Thermosetting plastics	8.2.2 melamine formaldehyde	MF	Albanit		Melmex	Melbrite		Isomin			Biramin		
			MF	Duropal		Formica	Melochem		Perstop panel			Resimene		
			MF	Getalit			Minitrack							
			MF	Hornapal			Puriplast							
			MF	Hornit										
			MF	Madurit										
			MF	Maprenal										
			MF	Melan										
			MF	Melolam										
			MF	Melopas										
			MF	Nyhamin										
			MF	Pressal										
			MF	Resart										
			MF	Resopal										
			MF	Ricolor										
			MF	Supraplast										
			MF	Trespa-Duro										
			MF	Ultrapas										
				8.2.3 urea formaldehyde	UF	Bakelite			Gabrite					
					UF	Carbalit			Urochem					
					UF	Cibamin								
					UF	Kaurit								
					UF	Melocol								
					UF	Pollopas								
					UF	Resamin								
					UF	Urecoll								
				8.2.4 polyurethane resin	PUR	Baydur								
					PUR	Bayfill								
					PUR	Bayfit								
					PUR	Bayflex								
					PUR	Baynat								
					PUR	Baypreg								
					PUR	Contilan								
					PUR	Desmodur								
					PUR	Elastolan								
					PUR	Elastolit								
					PUR	Elastopal								
					PUR	Elastopan								
					PUR	Elastopor								
					PUR	Moltopren								
				PUR	Vulkollan									
				8.2.5 silicone resin	SI	Baysilon								Silicone
					SI	Silastic								Textolite
					SI	Silopren								
				8.2.6 thermosetting polyimide	PI	Sintimid								Kapton
					PI									Vespel SP
				8.2.7 unsaturated polyester resin	UP	Alpolit	Norsomix	Crystic Impel	Shimoco	Rigolac	Sonoglas			Freeflow
					UP	Ampal	Stratyl	Uralam			Vyloglass			Haysite
					UP	Artrite								Hetron
					UP	Dobeckan								Rosite
					UP	Durapreg								Selectron
					UP	Durax								
		UP	Durodet											

Technical information

Material table

F35



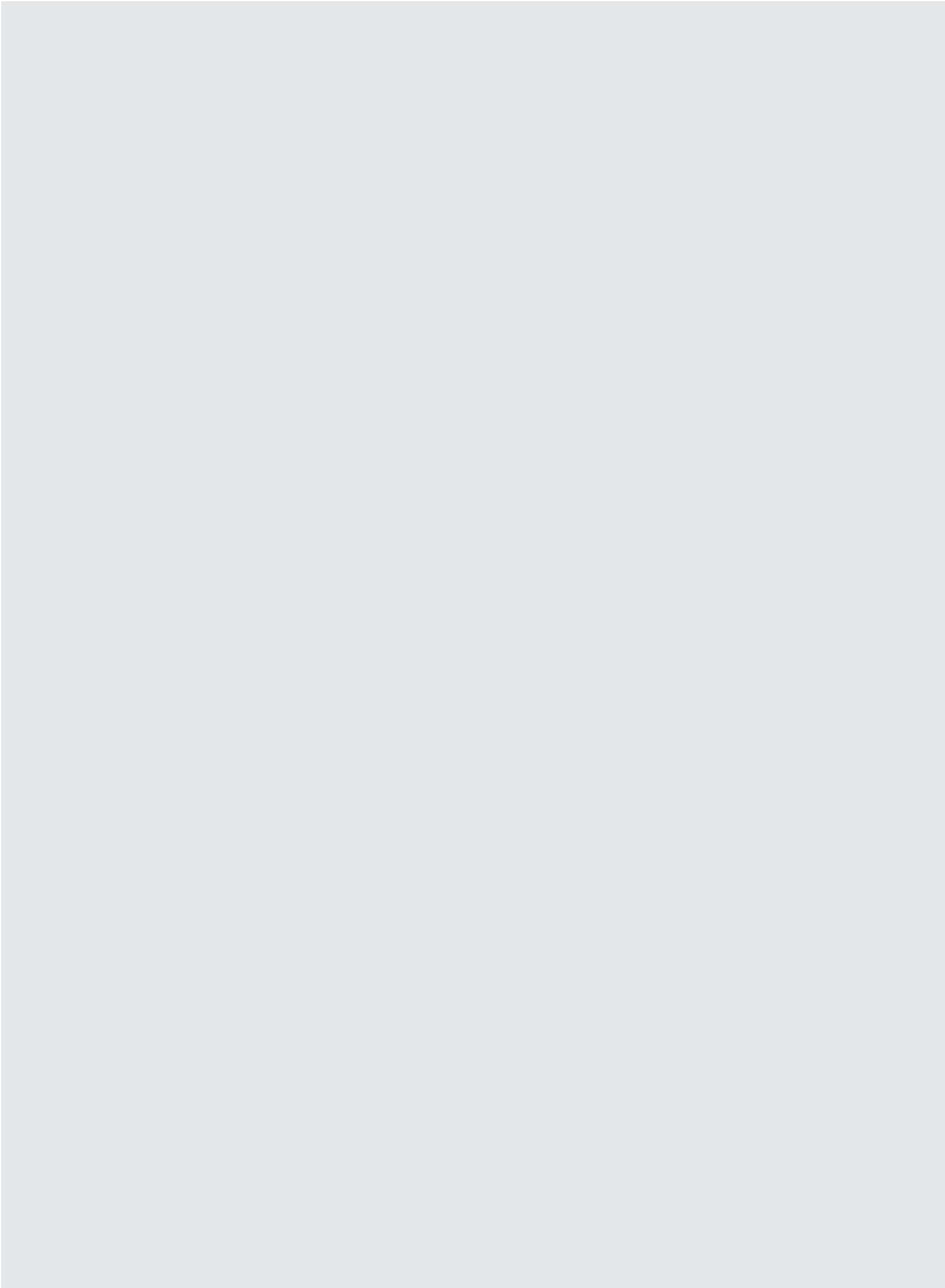

Material main group	Material sub-group	Quality	StNr	DIN	AFNOR	UNI	BS	JIS	SS	GOST	UNS	USA						
8 Plastics	8.2 Thermosetting plastics	8.2.7 unsaturated polyester resin	UP	Hostaset														
			UP	Keripol														
			UP	Laminac														
			UP	Leguval														
			UP	Menzolit														
			UP	Oldapal														
			UP	Palatal														
			UP	Polydur														
			UP	Polyleit														
			UP	Resipol														
			UP	Setarol														
			UP	Synolite														
			UP	Vestopal														
			UP	Vetrophen														
			UP	Viapal														
	8.2.8 epoxy resin	EP	Araldit				Epikote	Eponac	Epodite				Conapoxy					
		EP	Beckopox				Epon						Epiphan					
		EP	Duroxyn										Epocast					
		EP	Epoxin										Epolene					
		EP	Eurepox										Epolite					
		EP	Grilonit										Stycast					
		EP	Lekutherm															
		EP	Rütapox															
		EP	Trolon															
		8.3 Fibre-reinforced plastics	8.3.1 aramid-fibre reinforced	AFK	Kevlar													
				8.3.2 boron-fibre reinforced	BFK													
					8.3.3 carbon-fibre reinforced	CFK												
						8.3.4 glass-fibre reinforced	GFK											
							8.3.5 metal-fibre reinforced	MFK										
								8.3.6 synthetic-fibre reinforced	SFK									
8.4 Sandwich	8.4.1 plastic - metal - wood	P - M - H																
		8.4.2 honeycomb	honeycomb															
			8.4.3 metal	metal														
9 Graphite	9.1 Standard graphite	9.1.1 standard graphite	R8340	graphite														
			R8500X	graphite														
			Techno-graph 15	graphite														
			Techno-graph 30	graphite														
		9.1.2 wear-resistant graphite	R8510	graphite														
			R8650	graphite														
			Union Poco EDM C-3	graphite														
			Union Poco EDM1	graphite														
			Union Poco EDM3	graphite														





Introduction

	Product extensions	#R01#
	Overview	#R02#

Rotating adapters

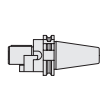
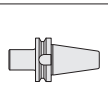
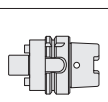
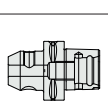
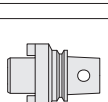
	DIN 69871	#R01#
	MAS-BT	#R02#
	HSK-A	#R03#
	PSC	#R04#
	UTS	#R05#

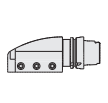

Stationary adapters

	HSK-T	#R01#
	PSC	#R02#
	UTS	#R03#

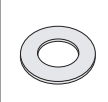
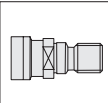
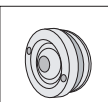
Accessories

	Collets, clamping nuts	#R01#
	Sealing rings	#R02#
	Pull studs	#R03#
	Other	#R04#

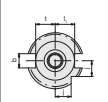
Technical information

	Dimensions of HSK adapters	#R01#
	Spare parts	#R02#

Spindle nose tooling

Extended product range



Spindle nose tooling from CERATIZIT

After launching the initial programme covering the most common standard adapters, Cutting Solutions by CERATIZIT now offers you an even broader range of spindle nose tools. Our range has been extended with over 500 additional items for

collet chucks, hydraulic chucks and the versatile and stable Polygon adapter interface. Please see below an overview of the entire programme.

Rotating spindle nose tools



Rotating spindle nose tools	DIN 69871	MAS-BT	HSK-A	UTS	PSC
Weldon adapters	●	●	●	●	●
Whistle Notch adapters	●	●	●	●	●
Shrink fit adapters	●	●	●	–	●
Hydraulic expansion chucks	●	●	●	–	●
Collet chucks type ER	●	●	●	●	●
Collet chucks type OZ	●	●	–	–	–
Adapters for threaded shank milling cutters	–	–	●	–	●
Combination shell mill adapters	●	●	–	–	●
Shell mill adapters, centre bolt	●	●	●	●	–
Shell mill adapters, 4 bolts	●	●	–	–	–
Morse taper adapters with thread	●	●	●	–	●
Test bars	●	●	●	–	●
Blanks	●	●	●	–	●

Stationary spindle nose tool



Stationary spindle nose tools	HSK-T	UTS	PSC
Shank holders	●	●	●
Boring bar holders	●	●	●
Extensions	●	●	●
Reducers	●	–	●
UTS adapters	●	–	●
Blanks	●	●	●
Test bars	●	●	●

● New!

Shrink fit adapters

An initial highlight of this extended range are the shrink fit adapters with a 4.5° profile. These are suitable for clamping solid carbide and HSS shanks. In addition to their highly precise concentricity, they are characterised by high rigidity, clamping forces (up to 640 Nm) as well as economic efficiency.

Programme

- ▲ Diameter range from 3-32 mm
- ▲ Available from short to extra-long versions
- ▲ Available connections for example SK, HSK-A and PSC
- ▲ Balancing class G2.5/n_{max} 25000 min⁻¹
- ▲ Concentricity starting from 0.003 mm



Hydraulic expansion chucks

Hydraulic expansion chucks are suitable for mounting tool shanks to DIN1835A+B / DIN6535HA+HB. The technical features of these expansion chucks are the vibration-damping effect during machining, a high radial rigidity as well as easy handling. No additional devices are required and the clamping area can be flexibly adapted by using reduction sleeves.

Programme

- ▲ Diameter range 6-32 mm
- ▲ Connections available for example SK, HSK-A and PSC
- ▲ Balancing class G2.5/n_{max} 25000 min⁻¹
- ▲ Concentricity better than 0.003 mm

Polygon adapters

Another highlight of the programme extension in the spindle nose tooling sector are the Polygon adapters (PSC). The advantages of the Polygon adapter in connection with the location face are:

- ▲ High rigidity and transverse rupture strength
- ▲ Maximum precision
- ▲ Accurate repeatability
- ▲ High torque moments





Spindle nose tooling

Overview



Rotating spindle nose tools		DIN69871	MAS-BT	HSK-A	PSC	UTS	
	Weldon adapters	#R01#	#R02#	#R03#	#R04#	#R05#	
	Whistle Notch adapters	#R07#	#R08#	#R09#	#R10#	#R11#	
	Shrink fit adapters	#R13#	#R14#	#R15#	#R16#		
	Hydraulic expansion chucks	#R19#	#R20#	#R21#	#R22#		
	Collet chucks type ER	#R25#	#R26#	#R27#	#R28#	#R29#	
	Collet chucks type ER-D	#R31#	#R32#				
	Collet chucks type OZ	#R37#	#R38#				
	Combination shell mill adapters	#R43#	#R44#		#R46#		
	Shell mill adapters, centre bolt	#R49#	#R50#	#R51#		#R53#	
	Adapters for threaded shank milling cutters			#R57#	#R58#		
	Shell mill adapters, 4 bolts	#R61#	#R62#				
	Morse taper adapters with tang	#R67#	#R68#	#R69#			
	Morse taper adapters with thread	#R73#	#R74#		#R76#		
	PSC adapters			#R81#			
	Test bars	#R85#	#R86#	#R87#	#R88#		

Rotating spindle nose tools		DIN69871	MAS-BT	HSK-A	PSC	UTS	
	Blanks	#R91#	#R92#	#R93#	#R94#		

Stationary spindle nose tools		DIN69871	MAS-BT	HSK-A	PSC	UTS	
	Tool holders 0°			#R03#	#R04#	#R05#	
	Tool holders 45°			#R09#	#R10#		
	Tool holders 90° / neutral			#R15#	#R16#		
	Multiple shank holders			#R21#	#R22#	#R23#	
	Boring bar holders			#R27#	#R28#	#R29#	
	Extensions			#R33#	#R34#	#R35#	
	Reducers			#R39#	#R40#		
	UTS adapters			#R45#			
	Assembly sets					#R53#	
	Test bars			#R57#	#R58#	#R59#	
	Blanks			#R63#	#R64#	#R65#	

Spindle nose tooling

Overview



Accessories		DIN69871	MAS-BT	HSK-A	PSC	UTS	
	Collets ER						#R06#
	Collets DIN6388-B						#R12#
	Lock nuts ER						#R18#
	Lock nuts ER-D						#R24#
	Lock nuts OZ						#R30#
	Sealing rings						#R36#
	Pull studs DIN 69872						#R42#
	Pull studs MAS-BT						#R48#
	Pull studs DIN 7388						#R54#
	Reducers MK						#R60#
	Reduction sleeves for hydraulic expansion chucks						#R66#
	Drive rings						#R72#



DIN 69871

Weldon adapters

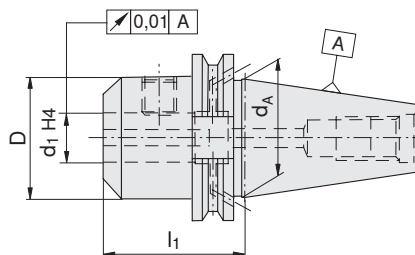
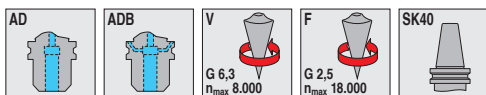

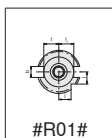

Type, description	d ₁ [mm]	l ₁ [mm]	d _A [mm]	D [mm]	
69871-ADB40-WE06-50-F	6	50	40	25	E01
69871-ADB40-WE06-50-V	6	50	40	25	E01
69871-ADB40-WE08-50-F	8	50	40	28	E02
69871-ADB40-WE08-50-V	8	50	40	28	E02
69871-ADB40-WE10-50-F	10	50	40	35	E03
69871-ADB40-WE10-50-V	10	50	40	35	E03
69871-ADB40-WE12-50-F	12	50	40	42	E04
69871-ADB40-WE12-50-V	12	50	40	42	E04
69871-ADB40-WE14-50-F	14	50	40	44	E04
69871-ADB40-WE14-50-V	14	50	40	44	E04
69871-AD40-WE16-35-F	16	35	40	48	E05
69871-AD40-WE16-35-V	16	35	40	48	E05
69871-ADB40-WE16-63-F	16	63	40	48	E05
69871-ADB40-WE16-63-V	16	63	40	48	E05
69871-ADB40-WE18-63-F	18	63	40	50	E05
69871-ADB40-WE18-63-V	18	63	40	50	E05
69871-AD40-WE20-35-F	20	35	40	50	E06
69871-AD40-WE20-35-V	20	35	40	50	E06
69871-ADB40-WE20-63-F	20	63	40	52	E06
69871-ADB40-WE20-63-V	20	63	40	52	E06
69871-AD40-WE25-40-F	25	40	40	50	E07
69871-AD40-WE25-40-V	25	40	40	50	E07
69871-ADB40-WE25-100-F	25	100	40	65	E07
69871-ADB40-WE25-100-V	25	100	40	65	E07
69871-ADB40-WE32-100-F	32	100	40	72	E08
69871-ADB40-WE32-100-V	32	100	40	72	E08
69871-ADB40-WE40-120-V	40	120	40	90	E09

E01	8395003300	6295000600
E02	8395003400	6295000800
E03	8395003500	6295001000
E04	8395003600	6295001200
E05	8395003700	6295001600
E06	8395027200	6295002000
E07	8395029000	6295002500
E08	8395029000	6295003200
E09		6295003200

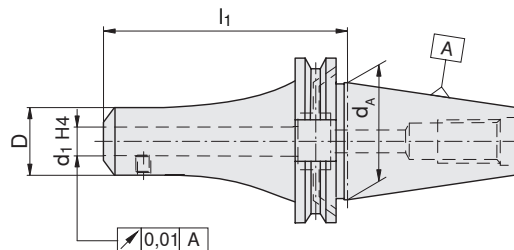
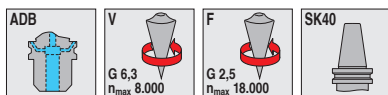



Type, description	d ₁ [mm]	l ₁ [mm]	d _A [mm]	D [mm]	
69871-ADB40-WE06-100-F	6	100	40	25	E01
69871-ADB40-WE06-100-V	6	100	40	25	E01
69871-ADB40-WE06-160-F	6	160	40	25	E01
69871-ADB40-WE06-160-V	6	160	40	25	E01
69871-ADB40-WE08-100-F	8	100	40	28	E02
69871-ADB40-WE08-100-V	8	100	40	28	E02
69871-ADB40-WE08-160-F	8	160	40	28	E02
69871-ADB40-WE08-160-V	8	160	40	28	E02
69871-ADB40-WE10-100-F	10	100	40	35	E03
69871-ADB40-WE10-100-V	10	100	40	35	E03
69871-ADB40-WE10-160-F	10	160	40	35	E03
69871-ADB40-WE10-160-V	10	160	40	35	E03
69871-ADB40-WE12-100-F	12	100	40	42	E04
69871-ADB40-WE12-100-V	12	100	40	42	E04
69871-ADB40-WE12-160-F	12	160	40	42	E04
69871-ADB40-WE12-160-V	12	160	40	42	E04
69871-ADB40-WE14-160-F	14	160	40	44	E04
69871-ADB40-WE14-160-V	14	160	40	44	E04
69871-ADB40-WE16-100-F	16	100	40	48	E05
69871-ADB40-WE16-100-V	16	100	40	48	E05
69871-ADB40-WE16-160-F	16	160	40	48	E05
69871-ADB40-WE16-160-V	16	160	40	48	E05
69871-ADB40-WE18-160-F	18	160	40	50	E05
69871-ADB40-WE18-160-V	18	160	40	50	E05
69871-ADB40-WE20-100-F	20	100	40	52	E06
69871-ADB40-WE20-100-V	20	100	40	52	E06
69871-ADB40-WE20-160-F	20	160	40	52	E06
69871-ADB40-WE20-160-V	20	160	40	52	E06
69871-ADB40-WE25-160-F	25	160	40	65	E07
69871-ADB40-WE25-160-V	25	160	40	65	E07

		
E01	8395003300	6295000600
E02	8395003400	6295000800
E03	8395003500	6295001000
E04	8395003600	6295001200
E05	8395003700	6295001600
E06	8395027200	6295002000
E07	8395029000	6295002500

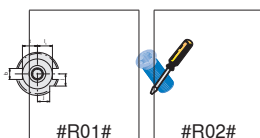

DIN 69871

Weldon adapters

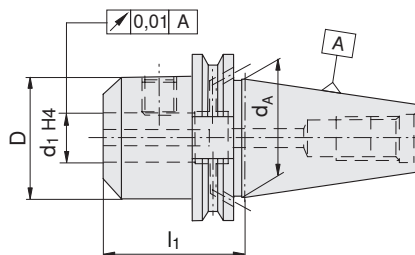
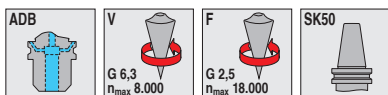

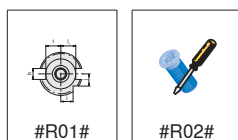

Type, description	d ₁ [mm]	l ₁ [mm]	d _A [mm]	D [mm]	
69871-ADB50-WE06-63-F	6	63	50	25	E01
69871-ADB50-WE06-63-V	6	63	50	25	E01
69871-ADB50-WE08-63-F	8	63	50	28	E02
69871-ADB50-WE08-63-V	8	63	50	28	E02
69871-ADB50-WE10-63-F	10	63	50	35	E03
69871-ADB50-WE10-63-V	10	63	50	35	E03
69871-ADB50-WE12-63-F	12	63	50	42	E04
69871-ADB50-WE12-63-V	12	63	50	42	E04
69871-ADB50-WE14-63-F	14	63	50	44	E04
69871-ADB50-WE14-63-V	14	63	50	44	E04
69871-ADB50-WE16-63-F	16	63	50	48	E05
69871-ADB50-WE16-63-V	16	63	50	48	E05
69871-ADB50-WE18-63-F	18	63	50	50	E05
69871-ADB50-WE18-63-V	18	63	50	50	E05
69871-ADB50-WE20-63-F	20	63	50	52	E06
69871-ADB50-WE20-63-V	20	63	50	52	E06
69871-ADB50-WE25-80-F	25	80	50	65	E07
69871-ADB50-WE25-80-V	25	80	50	65	E07
69871-ADB50-WE32-100-F	32	100	50	72	E08
69871-ADB50-WE32-100-V	32	100	50	72	E08
69871-ADB50-WE40-120-V	40	120	50	90	E09

E01	8395003300	6295000600
E02	8395003400	6295000800
E03	8395003500	6295001000
E04	8395003600	6295001200
E05	8395003700	6295001600
E06	8395027200	6295002000
E07	8395029000	6295002500
E08	8395029000	6295003200
E09		6295003200

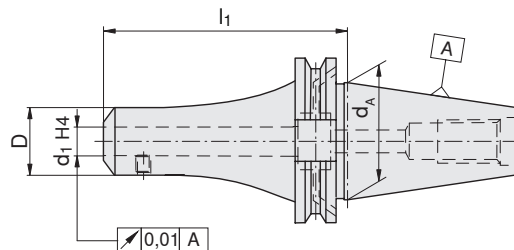
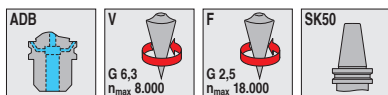



Type, description	d ₁ [mm]	l ₁ [mm]	d _A [mm]	D [mm]	
69871-ADB50-WE06-100-V	6	100	50	25	E01
69871-ADB50-WE06-160-V	6	160	50	25	E01
69871-ADB50-WE08-100-V	8	100	50	28	E02
69871-ADB50-WE08-160-V	8	160	50	28	E02
69871-ADB50-WE10-100-V	10	100	50	35	E03
69871-ADB50-WE10-160-V	10	160	50	35	E03
69871-ADB50-WE12-100-V	12	100	50	42	E04
69871-ADB50-WE12-160-V	12	160	50	42	E04
69871-ADB50-WE14-100-V	14	100	50	44	E04
69871-ADB50-WE14-160-V	14	160	50	44	E04
69871-ADB50-WE16-100-V	16	100	50	48	E05
69871-ADB50-WE16-160-V	16	160	50	48	E05
69871-ADB50-WE18-100-V	18	100	50	50	E05
69871-ADB50-WE18-160-V	18	160	50	50	E05
69871-ADB50-WE20-100-V	20	100	50	52	E06
69871-ADB50-WE20-160-V	20	160	50	52	E06
69871-ADB50-WE25-100-V	25	100	50	65	E07
69871-ADB50-WE25-160-V	25	160	50	65	E07
69871-ADB50-WE32-160-V	32	160	50	72	E08

		
E01	8395003300	6295000600
E02	8395003400	6295000800
E03	8395003500	6295001000
E04	8395003600	6295001200
E05	8395003700	6295001600
E06	8395027200	6295002000
E07	8395029000	6295002500
E08	8395029000	6295003200

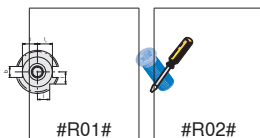

DIN 69871

Weldon adapters with through-coolant (IK)

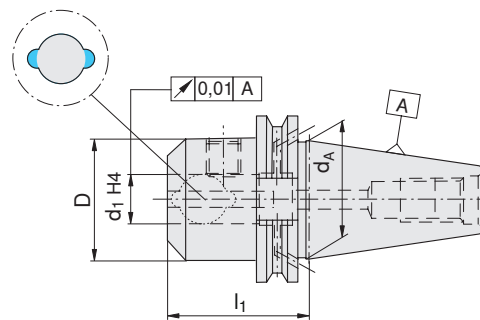
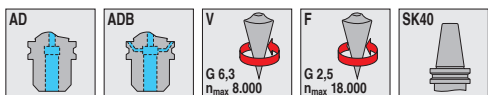

Type, description	d ₁ [mm]	l ₁ [mm]	d _A [mm]	D [mm]	
69871-ADB40-WE06IK-50-F	6	50	40	25	E01
69871-ADB40-WE06IK-50-V	6	50	40	25	E01
69871-ADB40-WE08IK-50-F	8	50	40	28	E02
69871-ADB40-WE08IK-50-V	8	50	40	28	E02
69871-ADB40-WE10IK-50-F	10	50	40	35	E03
69871-ADB40-WE10IK-50-V	10	50	40	35	E03
69871-ADB40-WE12IK-50-F	12	50	40	42	E04
69871-ADB40-WE12IK-50-V	12	50	40	42	E04
69871-ADB40-WE14IK-50-F	14	50	40	44	E04
69871-ADB40-WE14IK-50-V	14	50	40	44	E04
69871-AD40-WE16IK-35-V	16	35	40	48	E05
69871-ADB40-WE16IK-63-F	16	63	40	48	E05
69871-ADB40-WE16IK-63-V	16	63	40	48	E05
69871-ADB40-WE18IK-63-F	18	63	40	50	E05
69871-ADB40-WE18IK-63-V	18	63	40	50	E05
69871-AD40-WE20IK-35-V	20	35	40	50	E06
69871-ADB40-WE20IK-63-F	20	63	40	52	E06
69871-ADB40-WE20IK-63-V	20	63	40	52	E06
69871-AD40-WE25IK-40-V	25	40	40	50	E07
69871-ADB40-WE25IK-100-F	25	100	40	65	E07
69871-ADB40-WE25IK-100-V	25	100	40	65	E07
69871-ADB40-WE32IK-100-V	32	100	40	72	E08

E01	8395003300	6295000600
E02	8395003400	6295000800
E03	8395003500	6295001000
E04	8395003600	6295001200
E05	8395003700	6295001600
E06	8395027200	6295002000
E07	8395029000	6295002500
E08	8395029000	6295003200

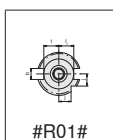

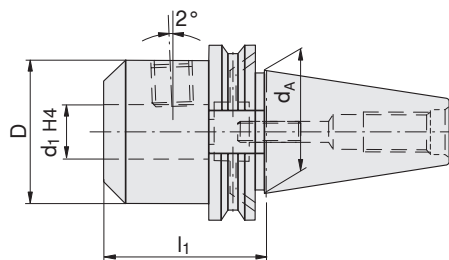
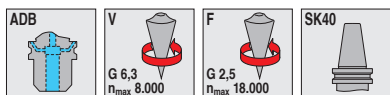

Type, description	d ₁ [mm]	l ₁ [mm]	d _A [mm]	D [mm]	
69871-ADB40-WN06-50-F	6	50	40	25	E01
69871-ADB40-WN06-50-V	6	50	40	25	E01
69871-ADB40-WN08-50-F	8	50	40	28	E02
69871-ADB40-WN08-50-V	8	50	40	28	E02
69871-ADB40-WN10-50-F	10	50	40	35	E03
69871-ADB40-WN10-50-V	10	50	40	35	E03
69871-ADB40-WN12-50-F	12	50	40	42	E04
69871-ADB40-WN12-50-V	12	50	40	42	E04
69871-ADB40-WN14-50-F	14	50	40	44	E04
69871-ADB40-WN14-50-V	14	50	40	44	E04
69871-ADB40-WN16-63-F	16	63	40	48	E05
69871-ADB40-WN16-63-V	16	63	40	48	E05
69871-ADB40-WN18-63-F	18	63	40	50	E05
69871-ADB40-WN18-63-V	18	63	40	50	E05
69871-ADB40-WN20-63-F	20	63	40	52	E06
69871-ADB40-WN20-63-V	20	63	40	52	E06

E01	8395003300	6295000600
E02	8395003400	6295000800
E03	8395003500	6295001000
E04	8395003600	6295001200
E05	8395003700	6295001600
E06	8395027200	6295002000

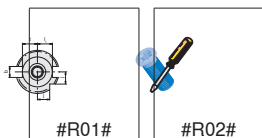

DIN 69871

Shrink fit adapters

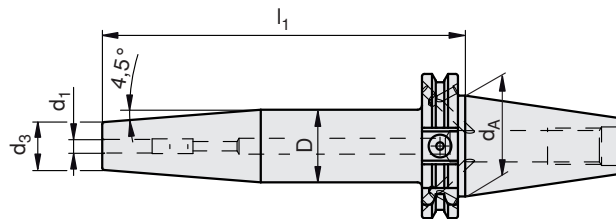
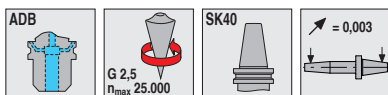

Type, description	d ₁ [mm]	l ₁ [mm]	d _A [mm]	D [mm]	d ₃ [mm]	
69871-ADB40-SF4.5°-3-70	3	70	40	17	12	
69871-ADB40-SF4.5°-3-120	3	120	40	17	12	
69871-ADB40-SF4.5°-4-70	4	70	40	17	12	
69871-ADB40-SF4.5°-4-120	4	120	40	17	12	
69871-ADB40-SF4.5°-5-70	5	70	40	17	12	
69871-ADB40-SF4.5°-5-120	5	120	40	17	12	
69871-ADB40-SF4.5°-6-80	6	80	40	30.6	21	E01
69871-ADB40-SF4.5°-6-120	6	120	40	32	21	E01
69871-ADB40-SF4.5°-6-160	6	160	40	32	21	E01
69871-ADB40-SF4.5°-8-80	8	80	40	30.5	21	E02
69871-ADB40-SF4.5°-8-120	8	120	40	32	21	E02
69871-ADB40-SF4.5°-8-160	8	160	40	32	21	E02
69871-ADB40-SF4.5°-10-80	10	80	40	33.6	24	E03
69871-ADB40-SF4.5°-10-120	10	120	40	34	24	E03
69871-ADB40-SF4.5°-10-160	10	160	40	34	24	E03
69871-ADB40-SF4.5°-12-80	12	80	40	33.6	24	E04
69871-ADB40-SF4.5°-12-120	12	120	40	34	24	E04
69871-ADB40-SF4.5°-12-160	12	160	40	34	24	E04
69871-ADB40-SF4.5°-14-80	14	80	40	36.6	27	E04
69871-ADB40-SF4.5°-14-160	14	160	40	36	27	E04
69871-ADB40-SF4.5°-16-80	16	80	40	36.6	27	E05
69871-ADB40-SF4.5°-16-120	16	120	40	36	27	E05
69871-ADB40-SF4.5°-16-160	16	160	40	36	27	E05
69871-ADB40-SF4.5°-18-80	18	80	40	42.6	33	E05
69871-ADB40-SF4.5°-18-160	18	160	40	44	33	E05
69871-ADB40-SF4.5°-20-80	20	80	40	42.6	33	E06
69871-ADB40-SF4.5°-20-120	20	120	40	44	33	E06
69871-ADB40-SF4.5°-20-160	20	160	40	44	33	E06
69871-ADB40-SF4.5°-25-100	25	100	40	50	44	E06
69871-ADB40-SF4.5°-25-160	25	160	40	50	44	E06
69871-ADB40-SF4.5°-32-100	32	100	40	50	44	E06

For shanks with tolerance h6 or better

E01	12087062
E02	12087063
E03	12087064
E04	12087065
E05	12087066
E06	12087067

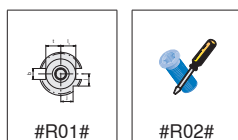

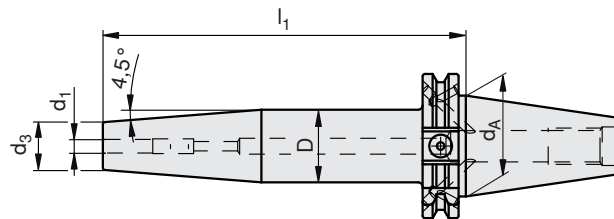
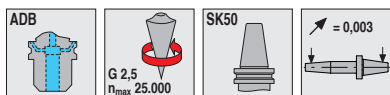

Type, description	d ₁ [mm]	l ₁ [mm]	d _A [mm]	D [mm]	d ₃ [mm]	
69871-ADB50-SF4.5°-6-80	6	80	50	30.6	21	E01
69871-ADB50-SF4.5°-6-160	6	160	50	32	21	E01
69871-ADB50-SF4.5°-6-200	6	200	50	27	21	E01
69871-ADB50-SF4.5°-8-80	8	80	50	30.6	21	E02
69871-ADB50-SF4.5°-8-160	8	160	50	32	21	E02
69871-ADB50-SF4.5°-8-200	8	200	50	27	21	E02
69871-ADB50-SF4.5°-10-80	10	80	50	33.6	24	E03
69871-ADB50-SF4.5°-10-160	10	160	50	34	24	E03
69871-ADB50-SF4.5°-10-200	10	200	50	34	24	E03
69871-ADB50-SF4.5°-12-80	12	80	50	33.6	24	E04
69871-ADB50-SF4.5°-12-160	12	160	50	34	24	E04
69871-ADB50-SF4.5°-12-200	12	200	50	34	24	E04
69871-ADB50-SF4.5°-14-80	14	80	50	36.6	27	E04
69871-ADB50-SF4.5°-14-160	14	160	50	36	27	E04
69871-ADB50-SF4.5°-14-200	14	200	50	36	27	E04
69871-ADB50-SF4.5°-16-80	16	80	50	36.6	27	E05
69871-ADB50-SF4.5°-16-160	16	160	50	36	27	E05
69871-ADB50-SF4.5°-16-200	16	200	50	36	27	E05
69871-ADB50-SF4.5°-18-80	18	80	50	42.6	33	E05
69871-ADB50-SF4.5°-18-160	18	160	50	44	33	E05
69871-ADB50-SF4.5°-18-200	18	200	50	44	33	E05
69871-ADB50-SF4.5°-20-80	20	80	50	42.6	33	E06
69871-ADB50-SF4.5°-20-160	20	160	50	44	33	E06
69871-ADB50-SF4.5°-20-200	20	200	50	44	33	E06
69871-ADB50-SF4.5°-25-100	25	100	50	53	44	E06
69871-ADB50-SF4.5°-25-160	25	160	50	53	44	E06
69871-ADB50-SF4.5°-25-200	25	200	50	53	44	E06
69871-ADB50-SF4.5°-32-100	32	100	50	56.8	44	E06
69871-ADB50-SF4.5°-32-160	32	160	50	56	44	E06
69871-ADB50-SF4.5°-32-200	32	200	50	53	44	E06

For shanks with tolerance h6 or better

E01	12087062
E02	12087063
E03	12087064
E04	12087065
E05	12087066
E06	12087067

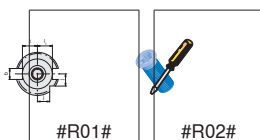

DIN 69871

Hydraulic expansion chucks

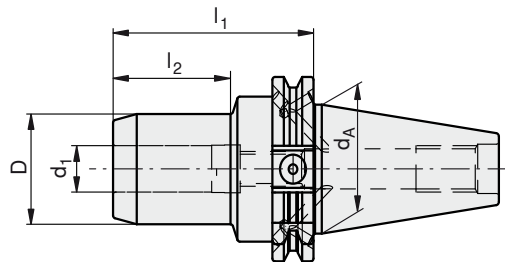

Type, description	d ₁ [mm]	l ₁ [mm]	l ₂ [mm]	d _A [mm]	D [mm]
69871-ADB40-HD06-80	6	80	40	40	26
69871-ADB40-HD08-80	8	80	40	40	28
69871-ADB40-HD10-80	10	80	40	40	30
69871-ADB40-HD12-80	12	80	40	40	32
69871-ADB40-HD14-80	14	80	40	40	34
69871-ADB40-HD16-80	16	80	46	40	38
69871-ADB40-HD18-80	18	80	46	40	40
69871-ADB40-HD20-80	20	80	46	40	42
69871-ADB40-HD25-95	25	95	60	40	55
69871-ADB40-HD32-95	32	95	60	40	63
69871-ADB50-HD06-80	6	80	40	50	26
69871-ADB50-HD08-80	8	80	40	50	28
69871-ADB50-HD10-80	10	80	40	50	30
69871-ADB50-HD12-80	12	80	40	50	32
69871-ADB50-HD14-80	14	80	40	50	34
69871-ADB50-HD16-80	16	80	46	50	38
69871-ADB50-HD18-80	18	80	46	50	40
69871-ADB50-HD20-80	20	80	46	50	42
69871-ADB50-HD25-100	25	100	55	50	55
69871-ADB50-HD32-100	32	100	55	50	63

⚠ For tools with shank to DIN 1835 A+B and DIN 6535 HA+HB
Shank to DIN 6535 HE in connection with reduction sleeves

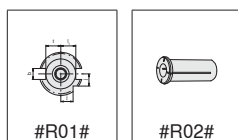

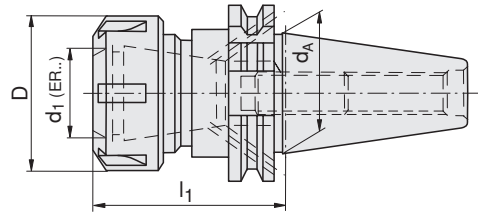
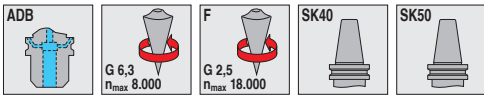

Type, description	d ₁ [mm]	l ₁ [mm]	d _A [mm]	D [mm]	
69871-ADB40-ER16-60	16	60	40	32	E01
69871-ADB40-ER16-60-F	16	60	40	32	E01
69871-ADB40-ER16-120	16	120	40	32	E01
69871-ADB40-ER16-120-F	16	120	40	32	E01
69871-ADB40-ER25-70	25	70	40	42	E02
69871-ADB40-ER25-70-F	25	70	40	42	E02
69871-ADB40-ER25-120	25	120	40	42	E02
69871-ADB40-ER25-120-F	25	120	40	42	E02
69871-ADB40-ER32-70	32	70	40	50	E03
69871-ADB40-ER32-70-F	32	70	40	50	E03
69871-ADB40-ER32-120	32	120	40	50	E03
69871-ADB40-ER32-120-F	32	120	40	50	E03
69871-ADB40-ER40-70	40	70	40	63	E04
69871-ADB40-ER40-70-F	40	70	40	63	E04
69871-ADB50-ER25-70	25	70	50	42	E02
69871-ADB50-ER25-100	25	100	50	42	E02
69871-ADB50-ER25-160	25	160	50	42	E02
69871-ADB50-ER32-70	32	70	50	50	E03
69871-ADB50-ER32-100	32	100	50	50	E03
69871-ADB50-ER32-160	32	160	50	50	E03
69871-ADB50-ER40-70	40	70	50	63	E04
69871-ADB50-ER40-100	40	100	50	63	E04

E01	6295005400		8335711600
E02	6295005500	8395001000	8335712500
E03	6295005600	8395001000	8335713200
E04	6295005700	8395001100	8335714000

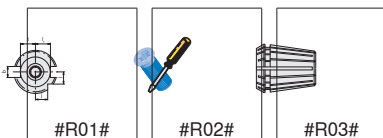



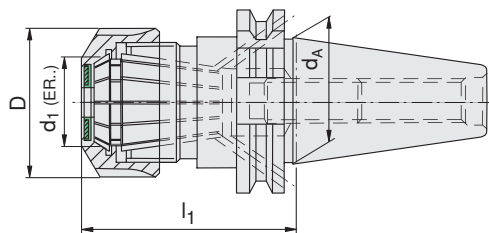
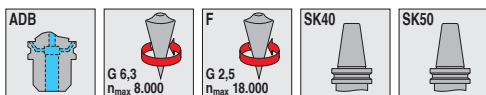

DIN 69871

Collet chucks type ER-D





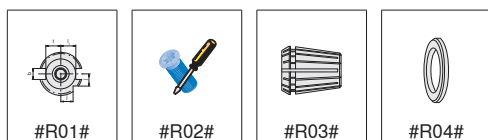

Type, description	d ₁ [mm]	l ₁ [mm]	d _A [mm]	D [mm]	
69871-ADB40-ER25D-73	25	73	40	42	E01
69871-ADB40-ER25D-73-F	25	73	40	42	E01
69871-ADB40-ER25D-123	25	123	40	42	E01
69871-ADB40-ER25D-123-F	25	123	40	42	E01
69871-ADB40-ER32D-73	32	73	40	50	E02
69871-ADB40-ER32D-73-F	32	73	40	50	E02
69871-ADB40-ER32D-123	32	123	40	50	E02
69871-ADB40-ER32D-123-F	32	123	40	50	E02
69871-ADB40-ER40D-73	40	73	40	63	E03
69871-ADB40-ER40D-73-F	40	73	40	63	E03
69871-ADB40-ER40D-123	40	123	40	63	E03
69871-ADB40-ER40D-123-F	40	123	40	63	E03
69871-ADB50-ER25D-73	25	73	50	42	E01
69871-ADB50-ER25D-103	25	103	50	42	E01
69871-ADB50-ER32D-73	32	73	50	50	E02
69871-ADB50-ER32D-103	32	103	50	50	E02

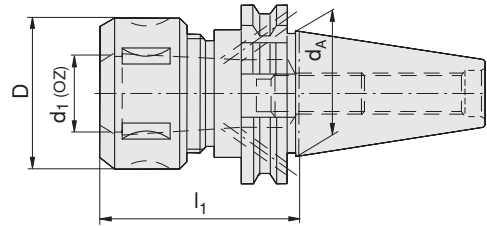
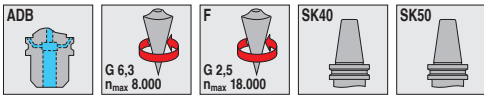
			
E01	8395005500	8395001000	8335712500
E02	8395005600	8395001000	8335713200
E03	8395005700	8395001100	8335714000





Type, description	d ₁ [mm]	l ₁ [mm]	d _A [mm]	D [mm]	
69871-ADB40-BC2-16-70	16	70	40	43	E01
69871-ADB40-BC2-16-70-F	16	70	40	43	E01
69871-ADB40-BC2-16-120	16	120	40	43	E01
69871-ADB40-BC2-16-120-F	16	120	40	43	E01
69871-ADB40-BC2-25-70	25	70	40	60	E02
69871-ADB40-BC2-25-70-F	25	70	40	60	E02
69871-ADB40-BC2-25-120	25	120	40	60	E02
69871-ADB40-BC2-25-120-F	25	120	40	60	E02
69871-ADB50-BC2-16-70	16	70	50	43	E01
69871-ADB50-BC2-16-100	16	100	50	43	E01
69871-ADB50-BC2-25-70	25	70	50	60	E02
69871-ADB50-BC2-25-100	25	100	50	60	E02
69871-ADB50-BC4-32-73	32	70	50	72	E03

			
E01	6295005000	8395001000	8335411600
E02	6295005100	8395001000	8335412500
E03		8395001100	8335413200

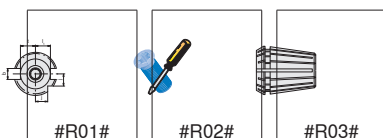

DIN 69871

Combination shell mill adapters

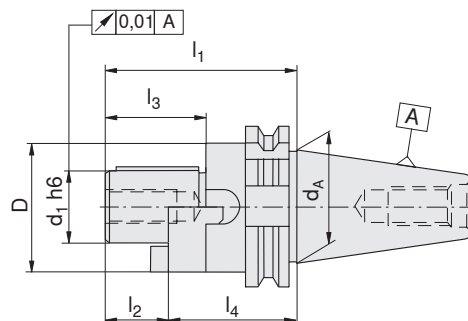
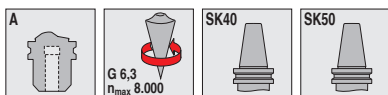

Type, description	d ₁ [mm]	d _A [mm]	D [mm]	l ₁ [mm]	l ₂ [mm]	l ₃ [mm]	l ₄ [mm]	
69871-A40-KA16-55	16	40	32	72	17	27	55	E01
69871-A40-KA22-55	22	40	40	74	19	31	55	E02
69871-A40-KA27-55	27	40	48	76	21	33	55	E03
69871-A40-KA32-60	32	40	58	84	24	38	60	E04
69871-A40-KA40-60	40	40	70	87	27	41	60	E05
69871-A50-KA16-55	16	50	32	72	17	27	55	E01
69871-A50-KA22-55	22	50	40	74	19	31	55	E02
69871-A50-KA27-55	27	50	48	76	21	33	55	E03
69871-A50-KA32-55	32	50	58	79	24	38	55	E04
69871-A50-KA40-55	40	50	70	82	27	41	55	E05
69871-A50-KA50-70	50	50	80	100	30	46	70	E06

E01	8337011600	8395028400	8395011300	8336701600	8336811600
E02	8337012200	8395028500	8395012400	8336702200	8336812200
E03	8337012700	8395028600	8395012500	8336702700	8336812700
E04	8337013200	8395028700	8395012600	8336703200	8336813200
E05	8337014000	8395028800	8395011200	8336704000	8336814000
E06	8337015000	8395028900		8336705000	

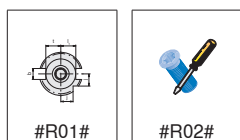

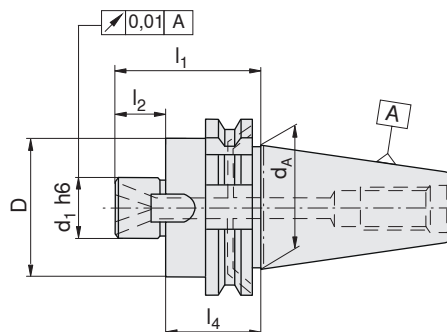
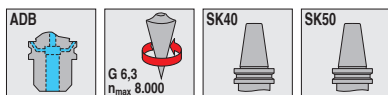

Type, description	d ₁ [mm]	d _A [mm]	D [mm]	l ₁ [mm]	l ₂ [mm]	l ₄ [mm]	
69871-ADB40-QA16-44	16	40	38	61	17	44	E01
69871-ADB40-QA16-100	16	40	38	117	17	100	E01
69871-ADB40-QA16-160	16	40	38	177	17	160	E01
69871-ADB40-QA22-44	22	40	48	63	19	44	E02
69871-ADB40-QA22-100	22	40	48	119	19	100	E02
69871-ADB40-QA22-160	22	40	48	179	19	160	E02
69871-ADB40-QA27-55	27	40	58	76	21	55	E03
69871-ADB40-QA27-100	27	40	58	121	21	100	E03
69871-ADB40-QA27-160	27	40	58	181	21	160	E03
69871-ADB40-QA32-50	32	40	78	74	24	50	E04
69871-ADB40-QA32-100	32	40	78	124	24	100	E04
69871-ADB40-QA32-160	32	40	78	184	24	160	E04
69871-ADB40-QA40-50	40	40	88	77	27	50	E05
69871-ADB40-QA40-100	40	40	88	127	27	100	E05
69871-ADB40-QA40-160	40	40	88	187	27	160	E05
69871-ADB50-QA16-44	16	50	38	61	17	44	E01
69871-ADB50-QA16-100	16	50	38	117	17	100	E01
69871-ADB50-QA16-160	16	50	38	177	17	160	E01
69871-ADB50-QA22-44	22	50	48	61	19	44	E02
69871-ADB50-QA22-100	22	50	48	119	19	100	E02
69871-ADB50-QA22-160	22	50	48	179	19	160	E02
69871-ADB50-QA27-44	27	50	58	65	21	44	E03
69871-ADB50-QA27-100	27	50	58	121	21	100	E03
69871-ADB50-QA27-160	27	50	58	181	21	160	E03
69871-ADB50-QA32-40	32	50	78	64	24	40	E04
69871-ADB50-QA32-100	32	50	78	124	24	100	E04
69871-ADB50-QA32-160	32	50	78	184	24	160	E04
69871-ADB50-QA40-50	40	50	88	77	27	50	E05
69871-ADB50-QA40-100	40	50	88	127	27	100	E05
69871-ADB50-QA40-160	40	50	88	187	27	160	E05

E01	8395012000	8395029600	8395011300	8336701600	8336811600
E02	8395012100	8395029700	8395012400	8336702200	8336812200
E03	8395012200	8395013600	8395012500	8336702700	8336812700
E04	8395012300	8395013700	8395012600	8336703200	8336813200
E05	8395029500	8395013800	8395011200	8336704000	8336814000

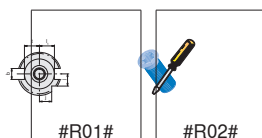

DIN 69871

Shell mill adapters for MT shanks / Morse taper adapters with tang

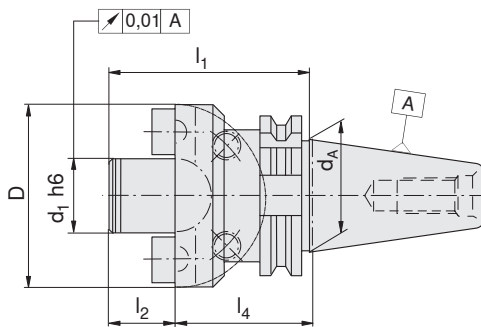
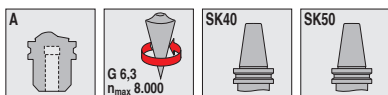

Type, description	d ₁ [mm]	d _A [mm]	D [mm]	l ₁ [mm]	l ₂ [mm]	l ₄ [mm]	
69871-A40-MA40-60	40	40	89	90	30	60	E01
69871-A50-MA40-70	40	50	89	100	30	70	E01
69871-A50-MA60-70	60	50	129	110	40	70	E02

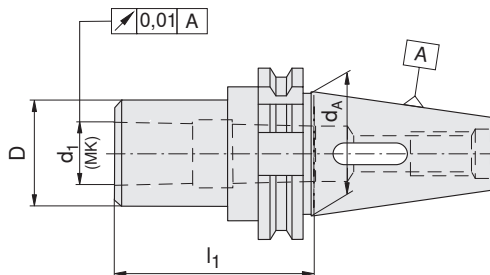
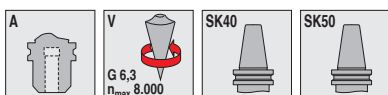

Type, description	d ₁ Morse taper [MK]	l ₁ [mm]	d _A [mm]	D [mm]
69871-A40-MK1D-50-V	1	50	40	25
69871-A40-MK2D-50-V	2	50	40	32
69871-A40-MK3D-70-V	3	70	40	40
69871-A40-MK4D-95-V	4	95	40	48
69871-A50-MK1D-50-V	1	50	50	25
69871-A50-MK2D-60-V	2	60	50	32
69871-A50-MK3D-65-V	3	65	50	40
69871-A50-MK4D-95-V	4	95	50	48
69871-A50-MK5D-105-V	5	105	50	63

E01	8395029500	8395013800	8395014000
E02	8395029800		333940 / 8395016000

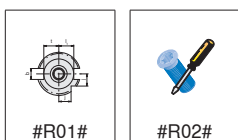

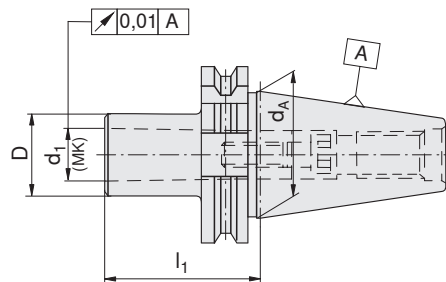
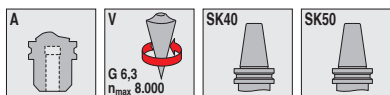

Type, description	d ₁ Morse taper [MK]	l ₁ [mm]	d _A [mm]	D [mm]	
69871-A40-MK1C-50-V	1	50	40	25	E01
69871-A40-MK2C-50-V	2	50	40	32	E02
69871-A40-MK3C-70-V	3	70	40	40	E03
69871-A40-MK4C-95-V	4	95	40	48	E04
69871-A50-MK1C-45-V	1	45	50	25	E05
69871-A50-MK2C-60-V	2	60	50	32	E06
69871-A50-MK3C-65-V	3	65	50	40	E07
69871-A50-MK4C-95-V	4	95	50	48	E04
69871-A50-MK5C-120-V	5	120	50	63	E08

E01	8335901300	8395003000	8395026000	8395026500
E02	8335901300	8395003100	8395026100	8395026700
E03	8335901700	8395003000	8395001800	8395026900
E04	8335902300	8395003100	8395001900	8395027000
E05	8335902000	8395003100	8395026000	8395026600
E06	8335902000	8395003100	8395001700	8395026800
E07	8335901700	8395003100	8395001700	8395026900
E08	8335903300	8395003100	8395026200	8395027100

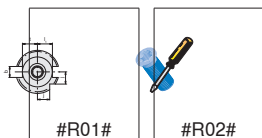

DIN 69871

Blanks / Test bars

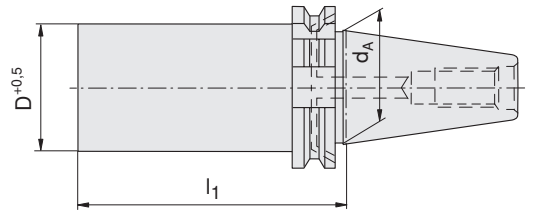

Type, description	d_A [mm]	D [mm]	l [mm]
69871-ADB40-HF63-250	40	63	250
69871-ADB50-HF63,5-300	50	63.5	300

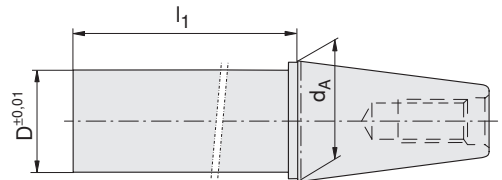

Type, description	d_A [mm]	D [mm]	l [mm]
DIN69871/MAS-BT-A40.KD.40.330	40	40	330
DIN69871/MAS-BT-A50.KD.50.330	50	50	330

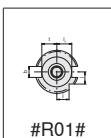

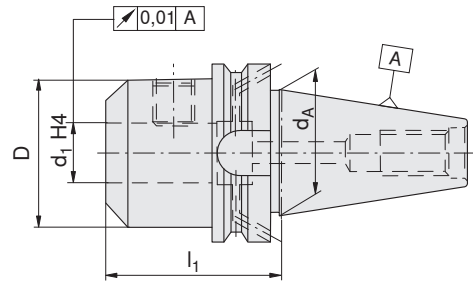
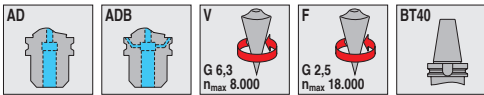

Type, description	d ₁ [mm]	l ₁ [mm]	d _A [mm]	D [mm]	
MAS-BT-ADB40-WE06-50-F	6	50	40	25	E01
MAS-BT-ADB40-WE06-50-V	6	50	40	25	E01
MAS-BT-ADB40-WE08-50-F	8	50	40	28	E02
MAS-BT-ADB40-WE08-50-V	8	50	40	28	E02
MAS-BT-ADB40-WE10-63-F	10	50	40	35	E03
MAS-BT-ADB40-WE10-63-V	10	50	40	35	E03
MAS-BT-ADB40-WE12-63-F	12	50	40	42	E04
MAS-BT-ADB40-WE12-63-V	12	50	40	42	E04
MAS-BT-ADB40-WE14-63-F	14	50	40	44	E04
MAS-BT-ADB40-WE14-63-V	14	50	40	44	E04
MAS-BT-AD40-WE16-35-F	16	35	40	48	E05
MAS-BT-AD40-WE16-35-V	16	35	40	48	E05
MAS-BT-ADB40-WE16-63-F	16	63	40	48	E06
MAS-BT-ADB40-WE16-63-V	16	63	40	48	E06
MAS-BT-ADB40-WE18-63-F	18	63	40	50	E06
MAS-BT-ADB40-WE18-63-V	18	63	40	50	E06
MAS-BT-AD40-WE20-35-F	20	35	40	50	E07
MAS-BT-AD40-WE20-35-V	20	35	40	50	E07
MAS-BT-ADB40-WE20-63-F	20	63	40	52	E08
MAS-BT-ADB40-WE20-63-V	20	63	40	52	E08
MAS-BT-AD40-WE25-40-F	25	40	40	50	E09
MAS-BT-AD40-WE25-40-V	25	40	40	50	E09
MAS-BT-ADB40-WE25-100-F	25	100	40	65	E10
MAS-BT-ADB40-WE25-100-V	25	100	40	65	E10
MAS-BT-ADB40-WE32-100-F	32	100	40	72	E11
MAS-BT-ADB40-WE32-100-V	32	100	40	72	E11
MAS-BT-ADB40-WE40-120-V	40	120	40	90	E12

E01	8395003300	6295000600
E02	8395003400	6295000800
E03	8395003500	6295001000
E04	8395003600	6295001200
E05		6295001600
E06	8395003700	6295001600
E07		6295002000
E08	8395027200	6295002000
E09		6295002500
E10	8395029000	6295002500
E11	8395029000	6295003200
E12		6295003200

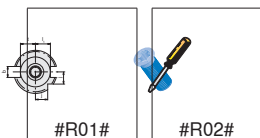

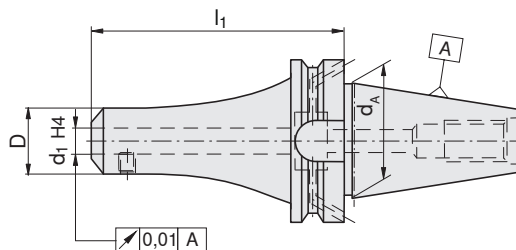
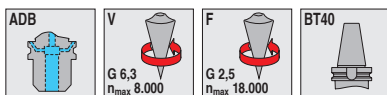

MAS-BT

Weldon adapters, long



Type, description	d ₁ [mm]	l ₁ [mm]	d _A [mm]	D [mm]	
MAS-BT-ADB40-WE06-100-F	6	100	40	25	E01
MAS-BT-ADB40-WE06-100-V	6	100	40	25	E01
MAS-BT-ADB40-WE06-160-F	6	160	40	25	E01
MAS-BT-ADB40-WE06-160-V	6	160	40	25	E01
MAS-BT-ADB40-WE08-100-F	8	100	40	28	E02
MAS-BT-ADB40-WE08-100-V	8	100	40	28	E02
MAS-BT-ADB40-WE08-160-F	8	160	40	28	E02
MAS-BT-ADB40-WE08-160-V	8	160	40	28	E02
MAS-BT-ADB40-WE10-100-F	10	100	40	35	E03
MAS-BT-ADB40-WE10-100-V	10	100	40	35	E03
MAS-BT-ADB40-WE10-160-F	10	160	40	35	E03
MAS-BT-ADB40-WE10-160-V	10	160	40	35	E03
MAS-BT-ADB40-WE12-100-F	12	100	40	42	E04
MAS-BT-ADB40-WE12-100-V	12	100	40	42	E04
MAS-BT-ADB40-WE12-160-F	12	160	40	42	E04
MAS-BT-ADB40-WE12-160-V	12	160	40	42	E04
MAS-BT-ADB40-WE14-160-F	14	160	40	44	E04
MAS-BT-ADB40-WE14-160-V	14	160	40	44	E04
MAS-BT-ADB40-WE16-100-F	16	100	40	48	E05
MAS-BT-ADB40-WE16-100-V	16	100	40	48	E05
MAS-BT-ADB40-WE16-160-F	16	160	40	48	E05
MAS-BT-ADB40-WE16-160-V	16	160	40	48	E05
MAS-BT-ADB40-WE18-160-F	18	160	40	50	E05
MAS-BT-ADB40-WE18-160-V	18	160	40	50	E05
MAS-BT-ADB40-WE20-100-F	20	100	40	52	E06
MAS-BT-ADB40-WE20-100-V	20	100	40	52	E06
MAS-BT-ADB40-WE20-160-F	20	160	40	52	E06
MAS-BT-ADB40-WE20-160-V	20	160	40	52	E06
MAS-BT-ADB40-WE25-160-F	25	160	40	65	E07
MAS-BT-ADB40-WE25-160-V	25	160	40	65	E07

		
E01	8395003300	6295000600
E02	8395003400	6295000800
E03	8395003500	6295001000
E04	8395003600	6295001200
E05	8395003700	6295001600
E06	8395027200	6295002000
E07	8395029000	6295002500

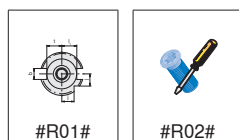

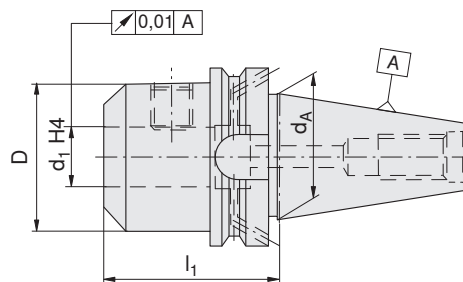
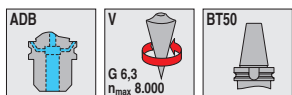

Type, description	d ₁ [mm]	l ₁ [mm]	d _A [mm]	D [mm]	
MAS-BT-ADB50-WE06-63-V	6	63	50	25	E01
MAS-BT-ADB50-WE08-63-V	8	63	50	28	E02
MAS-BT-ADB50-WE10-80-V	10	80	50	35	E03
MAS-BT-ADB50-WE12-80-V	12	80	50	42	E04
MAS-BT-ADB50-WE14-80-V	14	80	50	44	E04
MAS-BT-ADB50-WE16-80-V	16	80	50	48	E05
MAS-BT-ADB50-WE18-80-V	18	80	50	50	E05
MAS-BT-ADB50-WE20-80-V	20	80	50	52	E06
MAS-BT-ADB50-WE25-100-V	25	100	50	65	E07
MAS-BT-ADB50-WE32-105-V	32	105	50	72	E08
MAS-BT-ADB50-WE40-120-V	40	120	50	90	E09

E01	8395003300	6295000600
E02	8395003400	6295000800
E03	8395003500	6295001000
E04	8395003600	6295001200
E05	8395003700	6295001600
E06	8395027200	6295002000
E07	8395029000	6295002500
E08	8395029000	6295003200
E09		6295003200

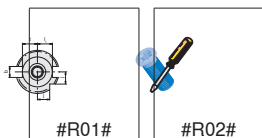

MAS-BT

Weldon adapters, long

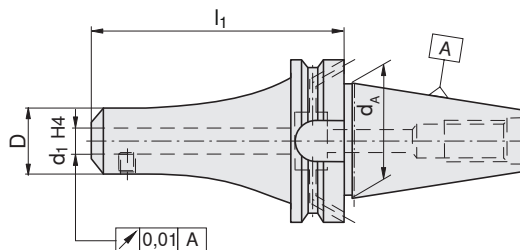
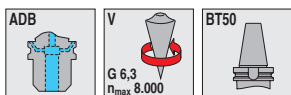

Type, description	d ₁ [mm]	l ₁ [mm]	d _A [mm]	D [mm]	
MAS-BT-ADB50-WE06-100-V	6	100	50	25	E01
MAS-BT-ADB50-WE06-160-V	6	160	50	25	E01
MAS-BT-ADB50-WE08-100-V	8	100	50	28	E02
MAS-BT-ADB50-WE08-160-V	8	160	50	28	E02
MAS-BT-ADB50-WE10-100-V	10	100	50	35	E03
MAS-BT-ADB50-WE10-160-V	10	160	50	35	E03
MAS-BT-ADB50-WE12-100-V	12	100	50	42	E04
MAS-BT-ADB50-WE12-160-V	12	160	50	42	E04
MAS-BT-ADB50-WE14-100-V	14	100	50	44	E04
MAS-BT-ADB50-WE14-160-V	14	160	50	44	E04
MAS-BT-ADB50-WE16-100-V	16	100	50	48	E05
MAS-BT-ADB50-WE16-160-V	16	160	50	48	E05
MAS-BT-ADB50-WE18-100-V	18	100	50	50	E05
MAS-BT-ADB50-WE18-160-V	18	160	50	50	E05
MAS-BT-ADB50-WE20-100-V	20	100	50	52	E06
MAS-BT-ADB50-WE20-160-V	20	160	50	52	E06
MAS-BT-ADB50-WE25-120-V	25	120	50	65	E07
MAS-BT-ADB50-WE25-160-V	25	160	50	65	E07
MAS-BT-ADB50-WE32-160-V	32	160	50	72	E08

E01	8395003300	6295000600
E02	8395003400	6295000800
E03	8395003500	6295001000
E04	8395003600	6295001200
E05	8395003700	6295001600
E06	8395027200	6295002000
E07	8395029000	6295002500
E08	8395029000	6295003200

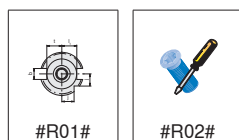

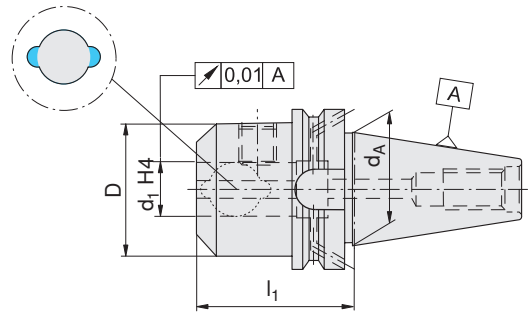
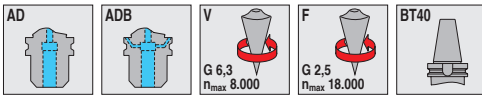

Type, description	d ₁ [mm]	l ₁ [mm]	d _A [mm]	D [mm]	
MAS-BT-ADB40-WE06IK-50-F	6	50	40	25	E01
MAS-BT-ADB40-WE06IK-50-V	6	50	40	25	E01
MAS-BT-ADB40-WE08IK-50-F	8	50	40	28	E02
MAS-BT-ADB40-WE08IK-50-V	8	50	40	28	E02
MAS-BT-ADB40-WE10IK-63-F	10	63	40	35	E03
MAS-BT-ADB40-WE10IK-63-V	10	63	40	35	E03
MAS-BT-ADB40-WE12IK-63-F	12	63	40	42	E04
MAS-BT-ADB40-WE12IK-63-V	12	63	40	42	E04
MAS-BT-ADB40-WE14IK-63-F	14	63	40	44	E04
MAS-BT-ADB40-WE14IK-63-V	14	63	40	44	E04
MAS-BT-AD40-WE16IK-35-V	16	35	40	48	E05
MAS-BT-ADB40-WE16IK-63-F	16	63	40	48	E05
MAS-BT-ADB40-WE16IK-63-V	16	63	40	48	E05
MAS-BT-ADB40-WE18IK-63-F	18	63	40	50	E05
MAS-BT-ADB40-WE18IK-63-V	18	63	40	50	E05
MAS-BT-AD40-WE20IK-35-V	20	35	40	50	E06
MAS-BT-ADB40-WE20IK-63-F	20	63	40	52	E06
MAS-BT-ADB40-WE20IK-63-V	20	63	40	52	E06
MAS-BT-AD40-WE25IK-40-V	25	40	40	50	E07
MAS-BT-ADB40-WE25IK-100-F	25	100	40	65	E07
MAS-BT-ADB40-WE25IK-100-V	25	100	40	65	E07
MAS-BT-ADB40-WE32IK-100-V	32	100	40	72	E08

E01	8395003300	6295000600
E02	8395003400	6295000800
E03	8395003500	6295001000
E04	8395003600	6295001200
E05	8395003700	6295001600
E06	8395027200	6295002000
E07	8395029000	6295002500
E08	8395029000	6295003200

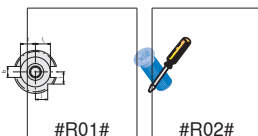

MAS-BT

Whistle Notch adapters

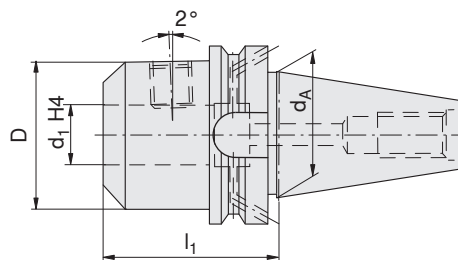
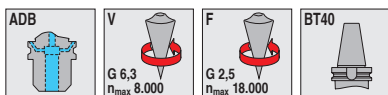

Type, description	d ₁ [mm]	l ₁ [mm]	d _A [mm]	D [mm]	
MAS-BT-ADB40-WN06-50-F	6	50	40	25	E01
MAS-BT-ADB40-WN06-50-V	6	50	40	25	E01
MAS-BT-ADB40-WN08-50-F	8	50	40	28	E02
MAS-BT-ADB40-WN08-50-V	8	50	40	28	E02
MAS-BT-ADB40-WN10-63-F	10	63	40	35	E03
MAS-BT-ADB40-WN10-63-V	10	63	40	35	E03
MAS-BT-ADB40-WN12-63-F	12	63	40	42	E04
MAS-BT-ADB40-WN12-63-V	12	63	40	42	E04
MAS-BT-ADB40-WN14-63-F	14	63	40	44	E04
MAS-BT-ADB40-WN14-63-V	14	63	40	44	E04
MAS-BT-ADB40-WN16-63-F	16	63	40	48	E05
MAS-BT-ADB40-WN16-63-V	16	63	40	48	E05
MAS-BT-ADB40-WN18-63-F	18	63	40	50	E05
MAS-BT-ADB40-WN18-63-V	18	63	40	50	E05
MAS-BT-ADB40-WN20-63-V	20	63	40	52	E06

E01	8395003300	6295000600
E02	8395003400	6295000800
E03	8395003500	6295001000
E04	8395003600	6295001200
E05	8395003700	6295001600
E06	8395027200	6295002000

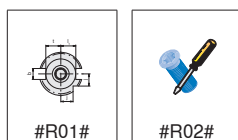

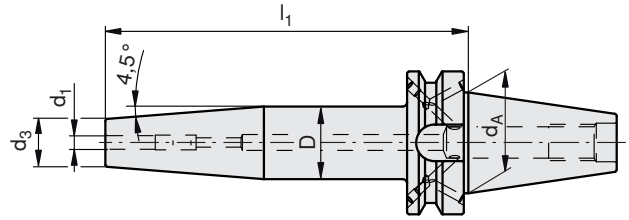
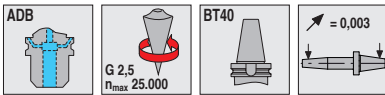

Type, description	d ₁ [mm]	l ₁ [mm]	d _A [mm]	D [mm]	d ₃ [mm]	
MAS-BT-ADB40-SF4.5°-3-80	3	80	40	17	12	
MAS-BT-ADB40-SF4.5°-4-80	4	80	40	17	12	
MAS-BT-ADB40-SF4.5°-5-80	5	80	40	17	12	
MAS-BT-ADB40-SF4.5°-6-90	6	90	40	31	21	E01
MAS-BT-ADB40-SF4.5°-6-160	6	160	40	32	21	E01
MAS-BT-ADB40-SF4.5°-8-90	8	90	40	31	21	E02
MAS-BT-ADB40-SF4.5°-8-160	8	160	40	32	21	E02
MAS-BT-ADB40-SF4.5°-10-90	10	90	40	34	24	E03
MAS-BT-ADB40-SF4.5°-10-160	10	160	40	34	24	E03
MAS-BT-ADB40-SF4.5°-12-90	12	90	40	34	24	E04
MAS-BT-ADB40-SF4.5°-12-160	12	160	40	34	24	E04
MAS-BT-ADB40-SF4.5°-14-90	14	90	40	37	27	E04
MAS-BT-ADB40-SF4.5°-14-160	14	160	40	36	27	E04
MAS-BT-ADB40-SF4.5°-16-90	16	90	40	37	27	E05
MAS-BT-ADB40-SF4.5°-16-160	16	160	40	36	27	E05
MAS-BT-ADB40-SF4.5°-18-90	18	90	40	43	33	E05
MAS-BT-ADB40-SF4.5°-18-160	18	160	40	44	33	E05
MAS-BT-ADB40-SF4.5°-20-90	20	90	40	43	33	E06
MAS-BT-ADB40-SF4.5°-20-160	20	160	40	44	33	E06
MAS-BT-ADB40-SF4.5°-25-100	25	100	40	53	44	E06
MAS-BT-ADB40-SF4.5°-25-160	25	160	40	53	44	E06

For shanks with tolerance h6 or better

E01	12087062
E02	12087063
E03	12087064
E04	12087065
E05	12087066
E06	12087067

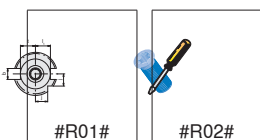

MAS-BT

Shrink fit adapters

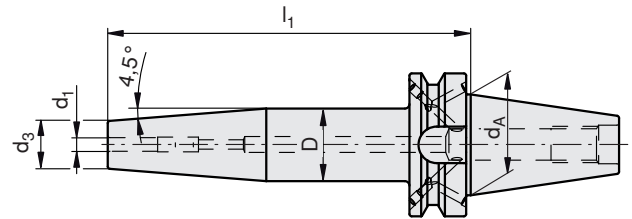
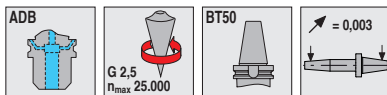

Type, description	d ₁ [mm]	l ₁ [mm]	d _A [mm]	D [mm]	d ₃ [mm]	
MAS-BT-ADB50-SF4.5°-6-100	6	100	50	31	21	E01
MAS-BT-ADB50-SF4.5°-6-160	6	160	50	32	21	E01
MAS-BT-ADB50-SF4.5°-8-100	8	100	50	31	21	E02
MAS-BT-ADB50-SF4.5°-8-160	8	160	50	32	21	E02
MAS-BT-ADB50-SF4.5°-10-100	10	100	50	34	24	E03
MAS-BT-ADB50-SF4.5°-10-160	10	160	50	34	24	E03
MAS-BT-ADB50-SF4.5°-12-100	12	100	50	34	24	E04
MAS-BT-ADB50-SF4.5°-12-160	12	160	50	34	24	E04
MAS-BT-ADB50-SF4.5°-14-100	14	100	50	37	27	E04
MAS-BT-ADB50-SF4.5°-14-160	14	160	50	36	27	E04
MAS-BT-ADB50-SF4.5°-16-100	16	100	50	37	27	E05
MAS-BT-ADB50-SF4.5°-16-160	16	160	50	36	27	E05
MAS-BT-ADB50-SF4.5°-18-100	18	100	50	43	33	E05
MAS-BT-ADB50-SF4.5°-18-160	18	160	50	44	33	E05
MAS-BT-ADB50-SF4.5°-20-100	20	100	50	43	33	E06
MAS-BT-ADB50-SF4.5°-20-160	20	160	50	44	33	E06
MAS-BT-ADB50-SF4.5°-25-120	25	120	50	57	44	E06
MAS-BT-ADB50-SF4.5°-25-160	25	160	50	53	44	E06
MAS-BT-ADB50-SF4.5°-32-120	32	120	50	57	44	E06
MAS-BT-ADB50-SF4.5°-32-160	32	160	50	53	44	E06

For shanks with tolerance h6 or better

E01	12087062
E02	12087063
E03	12087064
E04	12087065
E05	12087066
E06	12087067

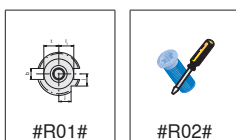

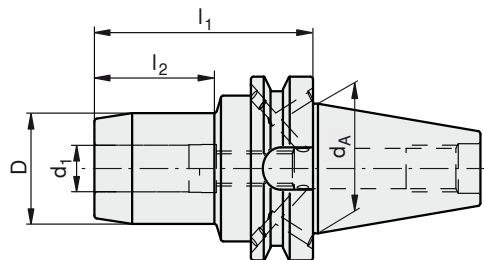
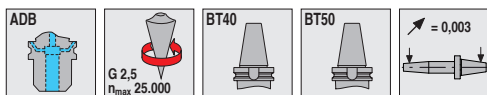

Type, description	d ₁ [mm]	l ₁ [mm]	l ₂ [mm]	d _A [mm]	D [mm]
MAS-BT-ADB40-HD06-90	6	90	40	40	26
MAS-BT-ADB40-HD08-90	8	90	40	40	28
MAS-BT-ADB40-HD10-90	10	90	40	40	30
MAS-BT-ADB40-HD12-90	12	90	40	40	32
MAS-BT-ADB40-HD14-90	14	90	40	40	34
MAS-BT-ADB40-HD16-90	16	90	40	40	38
MAS-BT-ADB40-HD18-90	18	90	40	40	40
MAS-BT-ADB40-HD20-90	20	90	40	40	42
MAS-BT-ADB40-HD25-90	25	90	40	40	55
MAS-BT-ADB40-HD32-90	32	90	40	40	63
MAS-BT-ADB50-HD06-110	6	110	40	50	26
MAS-BT-ADB50-HD08-110	8	110	40	50	28
MAS-BT-ADB50-HD10-110	10	110	40	50	30
MAS-BT-ADB50-HD12-110	12	110	40	50	32
MAS-BT-ADB50-HD14-110	14	110	40	50	34
MAS-BT-ADB50-HD16-110	16	110	40	50	38
MAS-BT-ADB50-HD18-110	18	110	40	50	40
MAS-BT-ADB50-HD20-110	20	110	40	50	42
MAS-BT-ADB50-HD25-110	25	110	40	50	55
MAS-BT-ADB50-HD32-115	32	115	40	50	63

 For tools with shank to DIN 1835 A+B and DIN 6535 HA+HB
Shank to DIN 6535 HE in connection with reduction sleeves

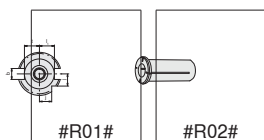



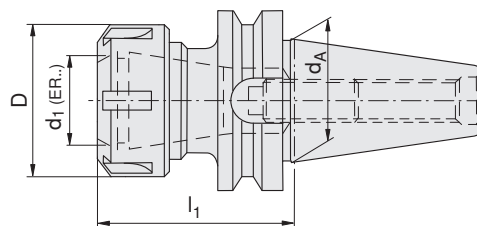
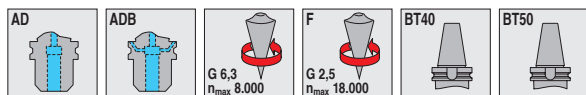

MAS-BT

Collet chucks type ER



Type, description	d ₁ [mm]	l ₁ [mm]	d _A [mm]	D [mm]	
MAS-BT-ADB40-ER16-60	16	60	40	32	E01
MAS-BT-ADB40-ER16-60-F	16	60	40	32	E01
MAS-BT-ADB40-ER16-120	16	120	40	32	E01
MAS-BT-ADB40-ER16-120-F	16	120	40	32	E01
MAS-BT-ADB40-ER25-70	25	70	40	42	E02
MAS-BT-ADB40-ER25-70-F	25	70	40	42	E02
MAS-BT-ADB40-ER25-120	25	120	40	42	E02
MAS-BT-ADB40-ER25-120-F	25	120	40	42	E02
MAS-BT-ADB40-ER32-70	32	70	40	50	E03
MAS-BT-ADB40-ER32-70-F	32	70	40	50	E03
MAS-BT-ADB40-ER32-120	32	120	40	50	E03
MAS-BT-ADB40-ER32-120-F	32	120	40	50	E03
MAS-BT-ADB40-ER40-70	40	70	40	63	E04
MAS-BT-ADB40-ER40-70-F	40	70	40	63	E04
MAS-BT-AD50-ER25-100	25	100	50	42	E02
MAS-BT-AD50-ER25-160	25	160	50	42	E02
MAS-BT-AD50-ER.2-20.75	32	75	50	50	E03
MAS-BT-AD50-ER32-100	32	100	50	50	E03
MAS-BT-AD50-ER32-160	32	160	50	50	E03
MAS-BT-AD50-ER.4-26.75	40	75	50	63	E04
MAS-BT-AD50-ER40-100	40	100	50	63	E04

			
E01	6295005400		8335711600
E02	6295005500	8395001000	8335712500
E03	6295005600	8395001000	8335713200
E04	6295005700	8395001100	8335714000





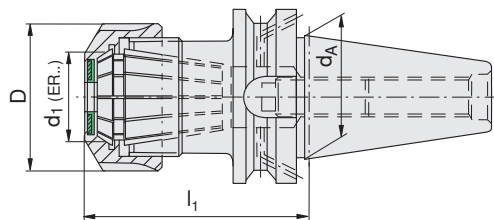
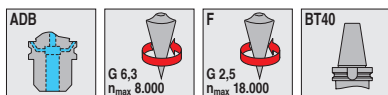

MAS-BT

Collet chucks type ER-D

G37



Type, description	d ₁ [mm]	l ₁ [mm]	d _A [mm]	D [mm]	
MAS-BT-ADB40-ER25D-73	25	73	40	42	E01
MAS-BT-ADB40-ER25D-123	25	123	40	42	E01
MAS-BT-ADB40-ER25D-123-F	25	123	40	42	E01
MAS-BT-ADB40-ER32D-73	32	73	40	50	E02
MAS-BT-ADB40-ER32D-73-F	32	73	40	50	E02
MAS-BT-ADB40-ER32D-123	32	123	40	50	E02
MAS-BT-ADB40-ER32D-123-F	32	123	40	50	E02
MAS-BT-ADB40-ER40D-73	40	73	40	63	E03

			
E01	8395005500	8395001000	8335712500
E02	8395005600	8395001000	8335713200
E03	8395005700	8395001100	8335714000

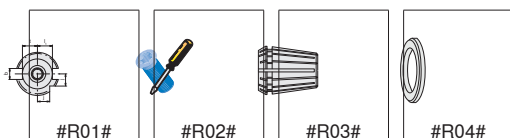



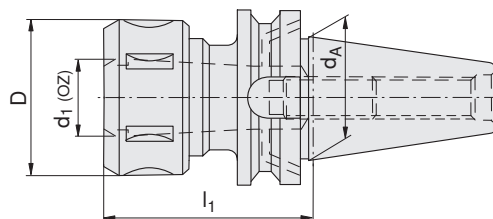
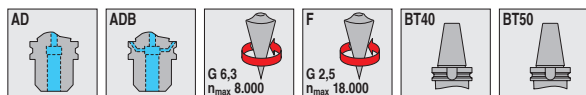

MAS-BT

Collet chucks type OZ



Type, description	d ₁ [mm]	l ₁ [mm]	d _A [mm]	D [mm]	
MAS-BT-ADB40-BC2-16-70	16	70	40	43	E01
MAS-BT-ADB40-BC2-16-120	16	120	40	43	E01
MAS-BT-ADB40-BC2-16-120-F	16	120	40	43	E01
MAS-BT-ADB40-BC2-25-70	25	70	40	60	E02
MAS-BT-ADB40-BC2-25-120	25	120	40	60	E02
MAS-BT-ADB40-BC2-25-120-F	25	120	40	60	E02
MAS-BT-AD50-BC2-25-90	25	90	50	60	E02
MAS-BT-AD50-BC2-25-120	25	120	50	60	E02
MAS-BT-AD50-BC4-32-100	32	100	50	72	E03
MAS-BT-AD50-BC4-32-120	32	120	50	72	E03

			
E01	6295005000	8395001000	8335411600
E02	6295005100	8395001000	8335412500
E03		8395001100	8335413200



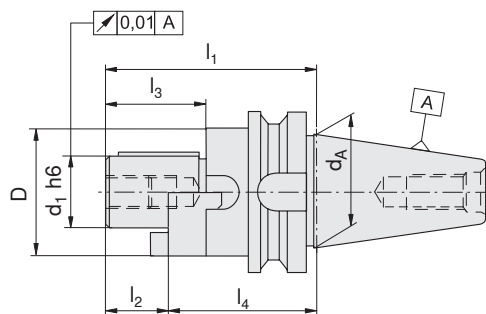
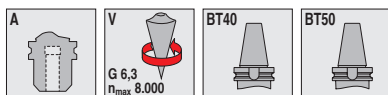

Type, description	d ₁ [mm]	d _A [mm]	D [mm]	l ₁ [mm]	l ₂ [mm]	l ₃ [mm]	l ₄ [mm]	
MAS-BT-A40.KA16.55.V	16	40	32	72	17	27	55	E01
MAS-BT-A40.KA22.55.V	22	40	40	74	19	31	55	E02
MAS-BT-A40.KA27.55.V	27	40	48	76	21	33	55	E03
MAS-BT-A40.KA32.60.V	32	40	58	84	24	38	60	E04
MAS-BT-A40.KA40.60.V	40	40	70	87	27	41	60	E05
MAS-BT-A50.KA16.70.V	16	50	32	72	17	27	70	E01
MAS-BT-A50.KA22.70.V	22	50	40	74	19	31	70	E02
MAS-BT-A50.KA27.70.V	27	50	48	76	21	33	70	E03
MAS-BT-A50.KA32.70.V	32	50	58	84	24	38	70	E04
MAS-BT-A50.KA40.70.V	40	50	70	87	27	41	70	E05

E01	8337011600	8395028400	8395011300	8336701600	8336811600
E02	8337012200	8395028500	8395012400	8336702200	8336812200
E03	8337012700	8395028600	8395012500	8336702700	8336812700
E04	8337013200	8395028700	8395012600	8336703200	8336813200
E05	8337014000	8395028800	8395011200	8336704000	8336814000

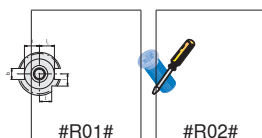

MAS-BT

Shell mill adapters, centre bolt

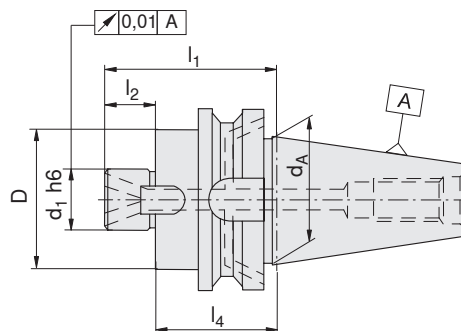
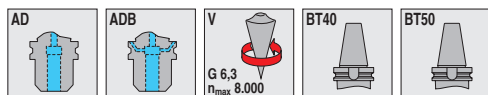

Type, description	d ₁ [mm]	d _A [mm]	D [mm]	l ₁ [mm]	l ₂ [mm]	l ₄ [mm]	
MAS-BT-ADB40.QA16.52.V	16	40	38	69	17	52	E01
MAS-BT-ADB40.QA16.100.V	16	40	38	117	17	100	E01
MAS-BT-ADB40.QA16.160.V	16	40	38	177	17	160	E01
MAS-BT-ADB40.QA22.52.V	22	40	48	71	19	52	E02
MAS-BT-ADB40.QA22.100.V	22	40	48	119	19	100	E02
MAS-BT-ADB40.QA22.160.V	22	40	48	179	19	160	E02
MAS-BT-ADB40.QA27.52.V	27	40	58	73	21	52	E03
MAS-BT-ADB40.QA27.100.V	27	40	58	121	21	100	E03
MAS-BT-ADB40.QA27.160.V	27	40	58	181	21	160	E03
MAS-BT-ADB40.QA32.50.V	32	40	78	74	24	50	E04
MAS-BT-ADB40.QA32.100.V	32	40	78	124	24	100	E04
MAS-BT-ADB40.QA32.160.V	32	40	78	184	24	160	E04
MAS-BT-ADB40.QA40.50.V	40	40	88	77	27	50	E05
MAS-BT-ADB40.QA40.100.V	40	40	88	127	27	100	E05
MAS-BT-ADB40.QA40.160.V	40	40	88	187	27	160	E05
MAS-BT-AD50.QA16.63.V	16	50	48	80	17	63	E01
MAS-BT-AD50.QA16.100.V	16	50	38	117	17	100	E01
MAS-BT-AD50.QA16.160.V	16	50	38	177	17	160	E01
MAS-BT-AD50.QA22.63.V	22	50	48	82	19	63	E02
MAS-BT-AD50.QA22.100.V	22	50	48	119	19	100	E02
MAS-BT-AD50.QA22.160.V	22	50	48	179	19	160	E02
MAS-BT-AD50-QA27-63	27	50	58	84	21	63	E03
MAS-BT-AD50.QA27.100.V	27	50	58	121	21	100	E03
MAS-BT-AD50.QA27.160.V	27	50	58	181	21	160	E03
MAS-BT-AD50.QA32.60.V	32	50	78	84	24	60	E04
MAS-BT-AD50.QA32.100.V	32	50	78	124	24	100	E04
MAS-BT-AD50.QA32.160.V	32	50	78	184	24	160	E04
MAS-BT-AD50.QA40.60.V	40	50	88	87	27	60	E05
MAS-BT-AD50.QA40.100.V	40	50	88	127	27	100	E05
MAS-BT-AD50.QA40.160.V	40	50	88	187	27	160	E05

E01	8395012000	8395029600	8395011300	8336701600	8336811600
E02	8395012100	8395029700	8395012400	8336702200	8336812200
E03	8395012200	8395013600	8395012500	8336702700	8336812700
E04	8395012300	8395013700	8395012600	8336703200	8336813200
E05	8395029500	8395013800	8395011200	8336704000	8336814000

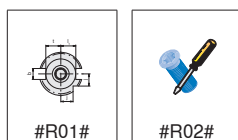

MAS-BT

Shell mill adapters, 4 bolts

G41

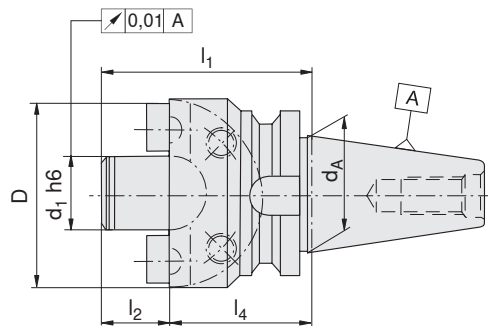
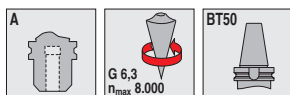

Type, description	d ₁ [mm]	d _A [mm]	D [mm]	l ₁ [mm]	l ₂ [mm]	l ₄ [mm]	
MAS-BT-A50-MA40-70	40	50	89	100	30	70	E01
MAS-BT-A50-MA60-80	60	50	129	120	40	80	E02

E01	8395029500	8395013800	8395014000
E02	8395029800		333940 / 8395016000

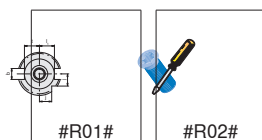

MAS-BT

Morse taper adapters with tang / Morse taper adapters with thread

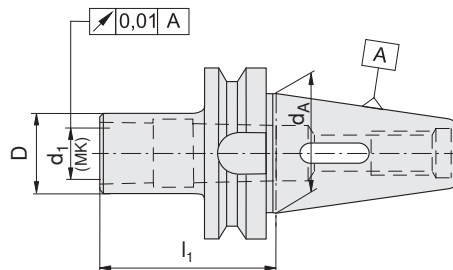
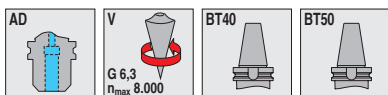

Type, description	d ₁ Morse taper [MK]	l ₁ [mm]	d _A [mm]	D [mm]
MAS-BT-AD40.KH.MK1.50.V	1	50	40	25
MAS-BT-AD40.KH.MK2.50.V	2	50	40	32
MAS-BT-AD40.KH.MK3.70.V	3	70	40	40
MAS-BT-AD40.KH.MK4.95.V	4	95	40	48
MAS-BT-AD50.KH.MK1.45.V	1	45	50	25
MAS-BT-AD50.KH.MK2.60.V	2	60	50	32
MAS-BT-AD50.KH.MK4.95.V	4	95	50	48
MAS-BT-AD50.KH.MK5.105.V	5	105	50	63

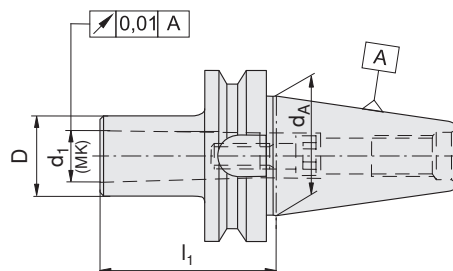
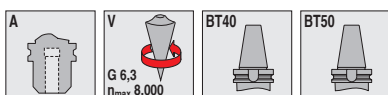

Type, description	d ₁ Morse taper [MK]	l ₁ [mm]	d _A [mm]	D [mm]	
MAS-BT-A40-MK3C-70-V	3	70	40	40	E01
MAS-BT-A40-MK4C-95-V	4	95	40	48	E02
MAS-BT-A50-MK1C-45-V	1	45	50	25	E03
MAS-BT-A50-MK2C-60-V	2	60	50	32	E04
MAS-BT-A50-MK3C-65-V	3	65	50	40	E01
MAS-BT-A50-MK4C-95-V	4	95	50	48	E02
MAS-BT-A50-MK5C-118-V	5	118	50	63	E05

E01	8335901700	8395003000	8395001800	8395026900
E02	8335902300	8395003100	8395001900	8395027000
E03	8335902000	8395003100	8395026000	8395026600
E04	8335902000	8395003100	8395001700	8395026800
E05	8335903300	8395003100	8395026200	8395027100

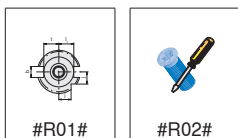

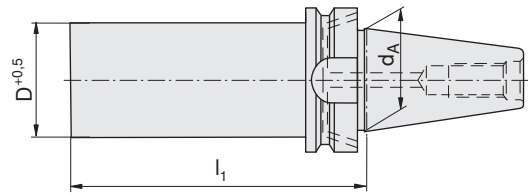
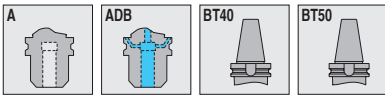

Type, description	d_A [mm]	D [mm]	l [mm]
MAS-BT-ADB40-HF63-250	40	63	250
MAS-BT-A50-HF63,5-300	50	63.5	300

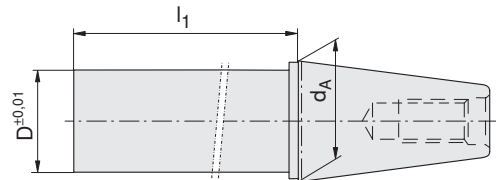

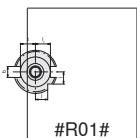

Type, description	d_A [mm]	D [mm]	l [mm]
DIN69871/MAS-BT-A40.KD.40.330	40	40	330
DIN69871/MAS-BT-A50.KD.50.330	50	50	330



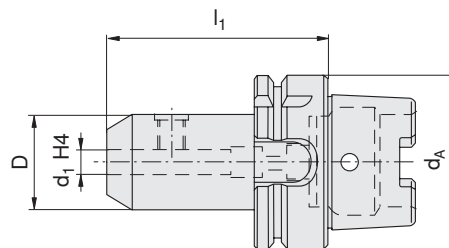
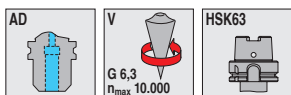

HSK-A

Weldon adapters



Type, description	d ₁ [mm]	l ₁ [mm]	d _A [mm]	D [mm]	
HSK63A-WE06-65-V	6	65	63	25	E01
HSK63A-WE06-160-V	6	160	63	22	E01
HSK63A-WE08-65-V	8	65	63	28	E02
HSK63A-WE08-160-V	8	160	63	24	E02
HSK63A-WE10-65-V	10	65	63	35	E03
HSK63A-WE10-160-V	10	160	63	25	E03
HSK63A-WE12-80-V	12	80	63	42	E04
HSK63A-WE12-160-V	12	160	63	26	E04
HSK63A-WE14-80-V	14	80	63	44	E04
HSK63A-WE14-160-V	14	160	63	28	E04
HSK63A-WE16-80-V	16	80	63	48	E05
HSK63A-WE16-160-V	16	160	63	30	E05
HSK63A-WE18-80-V	18	80	63	50	E05
HSK63A-WE18-160-V	18	160	63	32	E05
HSK63A-WE20-80-V	20	80	63	52	E06
HSK63A-WE20-160-V	20	160	63	34	E06
HSK63A-WE25-110-V	25	110	63	65	E07
HSK63A-WE25-160-V	25	160	63	65	E07
HSK63A-WE32-110-V	32	110	63	72	E08
HSK63A-WE32-160-V	32	160	63	72	E08

		
E01	8376006300	6295000600
E02	8376006300	6295000800
E03	8376006300	6295001000
E04	8376006300	6295001200
E05	8376006300	6295001600
E06	8376006300	6295002000
E07	8376006300	6295002500
E08	8376006300	6295003200

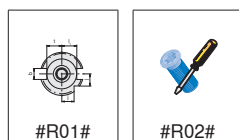

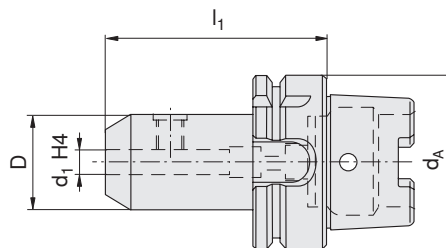
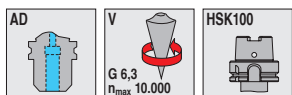

Type, description	d ₁ [mm]	l ₁ [mm]	d _A [mm]	D [mm]	
HSK100A-WE06-80-V	6	80	100	25	E01
HSK100A-WE06-160-V	6	160	100	22	E01
HSK100A-WE08-80-V	8	80	100	28	E02
HSK100A-WE08-160-V	8	160	100	24	E02
HSK100A-WE10-80-V	10	80	100	35	E03
HSK100A-WE10-160-V	10	160	100	25	E03
HSK100A-WE12-80-V	12	80	100	42	E04
HSK100A-WE12-160-V	12	160	100	25	E04
HSK100A-WE14-80-V	14	80	100	44	E04
HSK100A-WE14-160-V	14	160	100	28	E04
HSK100A-WE16-100-V	16	100	100	48	E05
HSK100A-WE16-160-V	16	160	100	30	E05
HSK100A-WE18-100-V	18	100	100	50	E05
HSK100A-WE18-160-V	18	160	100	32	E05
HSK100A-WE20-100-V	20	100	100	52	E06
HSK100A-WE20-160-V	20	160	100	34	E06
HSK100A-WE25-100-V	25	100	100	65	E07
HSK100A-WE25-160-V	25	160	100	65	E07
HSK100A-WE32-100-V	32	100	100	75	E08
HSK100A-WE32-160-V	32	160	100	75	E08

E01	8376010000	6295000600
E02	8376010000	6295000800
E03	8376010000	6295001000
E04	8376010000	6295001200
E05	8376010000	6295001600
E06	8376010000	6295002000
E07	8376010000	6295002500
E08	8376010000	6295003200

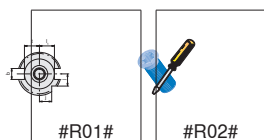

HSK-A

Whistle Notch adapters

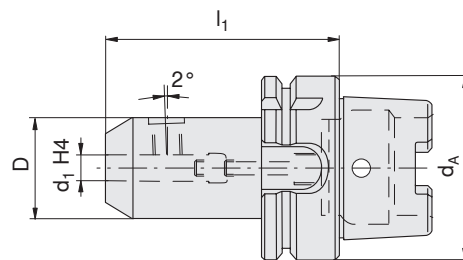
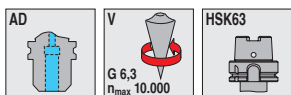

Type, description	d ₁ [mm]	l ₁ [mm]	d _A [mm]	D [mm]	
HSK63A-WN06-80-V	6	80	63	25	E01
HSK63A-WN06-160-V	6	160	63	22	E01
HSK63A-WN08-80-V	8	80	63	28	E02
HSK63A-WN08-160-V	8	160	63	24	E02
HSK63A-WN10-80-V	10	80	63	35	E03
HSK63A-WN10-160-V	10	160	63	25	E03
HSK63A-WN12-90-V	12	90	63	42	E04
HSK63A-WN12-160-V	12	160	63	26	E04
HSK63A-WN14-90-V	14	90	63	44	E04
HSK63A-WN14-160-V	14	160	63	28	E04
HSK63A-WN16-100-V	16	100	63	48	E05
HSK63A-WN16-160-V	16	160	63	30	E05
HSK63A-WN18-100-V	18	100	63	50	E05
HSK63A-WN18-160-V	18	160	63	32	E05
HSK63A-WN20-100-V	20	100	63	52	E06
HSK63A-WN20-160-V	20	160	63	34	E06
HSK63A-WN25-110-V	25	110	63	65	E07
HSK63A-WN25-160-V	25	160	63	65	E07
HSK63A-WN32-110-V	32	110	63	72	E08
HSK63A-WN32-160-V	32	160	63	72	E08

E01	8376006300	6295000600
E02	8376006300	6295000800
E03	8376006300	6295001000
E04	8376006300	6295001200
E05	8376006300	6295001600
E06	8376006300	6295002000
E07	8376006300	6295002500
E08	8376006300	6295003200

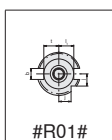

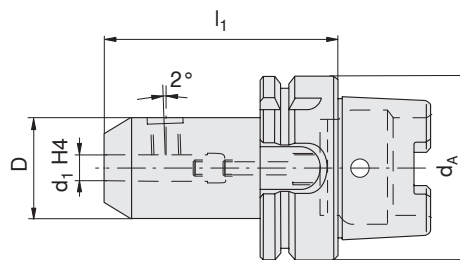
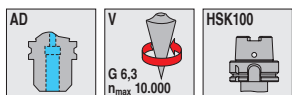

Type, description	d ₁ [mm]	l ₁ [mm]	d _A [mm]	D [mm]	
HSK100A-WN06-90-V	6	90	100	25	E01
HSK100A-WN06-160-V	6	160	100	22	E01
HSK100A-WN08-90-V	8	90	100	28	E02
HSK100A-WN08-160-V	8	160	100	24	E02
HSK100A-WN10-90-V	10	90	100	35	E03
HSK100A-WN10-160-V	10	160	100	25	E03
HSK100A-WN12-100-V	12	100	100	42	E04
HSK100A-WN12-160-V	12	160	100	26	E04
HSK100A-WN14-100-V	14	100	100	44	E04
HSK100A-WN14-160-V	14	160	100	28	E04
HSK100A-WN16-100-V	16	100	100	48	E05
HSK100A-WN16-160-V	16	160	100	30	E05
HSK100A-WN18-100-V	18	100	100	50	E05
HSK100A-WN18-160-V	18	160	100	32	E05
HSK100A-WN20-110-V	20	110	100	52	E06
HSK100A-WN20-160-V	20	160	100	34	E06
HSK100A-WN25-120-V	25	120	100	65	E07
HSK100A-WN25-160-V	25	160	100	65	E07
HSK100A-WN32-120-V	32	120	100	72	E08
HSK100A-WN32-160-V	32	160	100	72	E08

E01	8376010000	6295000600
E02	8376010000	6295000800
E03	8376010000	6295001000
E04	8376010000	6295001200
E05	8376010000	6295001600
E06	8376010000	6295002000
E07	8376010000	6295002500
E08	8376010000	6295003200

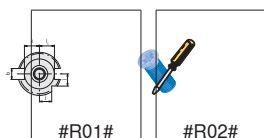

HSK-A

Shrink fit adapters

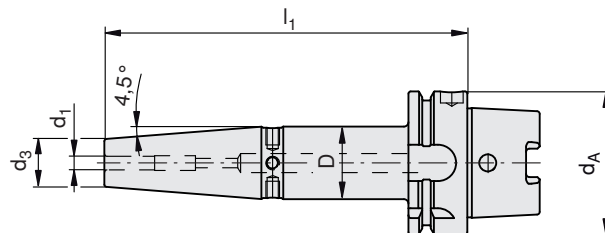
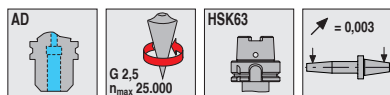

Type, description	d ₁ [mm]	l ₁ [mm]	d _A [mm]	D [mm]	d ₃ [mm]	
HSK63A-SF4.5°-3-80	3	80	63	17	12	
HSK63A-SF4.5°-3-120	3	120	63	17	12	
HSK63A-SF4.5°-3-160	3	160	63	17	12	
HSK63A-SF4.5°-4-80	4	80	63	17	12	
HSK63A-SF4.5°-4-120	4	120	63	17	12	
HSK63A-SF4.5°-4-160	4	160	63	17	12	
HSK63A-SF4.5°-5-80	5	80	63	17	12	
HSK63A-SF4.5°-5-120	5	120	63	17	12	
HSK63A-SF4.5°-5-160	5	160	63	17	12	
HSK63A-SF4.5°-6-80	6	80	63	30	21	E01
HSK63A-SF4.5°-6-120	6	120	63	32	21	E01
HSK63A-SF4.5°-6-160	6	160	63	32	21	E01
HSK63A-SF4.5°-6-200	6	200	63	32	21	E01
HSK63A-SF4.5°-8-80	8	80	63	30	21	E02
HSK63A-SF4.5°-8-120	8	120	63	32	21	E02
HSK63A-SF4.5°-8-160	8	160	63	32	21	E02
HSK63A-SF4.5°-8-200	8	200	63	32	21	E02
HSK63A-SF4.5°-10-85	10	85	63	33	24	E03
HSK63A-SF4.5°-10-120	10	120	63	34	24	E03
HSK63A-SF4.5°-10-160	10	160	63	34	24	E03
HSK63A-SF4.5°-10-200	10	200	63	34	24	E03
HSK63A-SF4.5°-12-90	12	90	63	34	24	E04
HSK63A-SF4.5°-12-120	12	120	63	34	24	E04
HSK63A-SF4.5°-12-160	12	160	63	34	24	E04
HSK63A-SF4.5°-12-200	12	200	63	34	24	E04
HSK63A-SF4.5°-14-90	14	90	63	37	27	E04
HSK63A-SF4.5°-14-120	14	120	63	36	27	E04
HSK63A-SF4.5°-14-160	14	160	63	36	27	E04
HSK63A-SF4.5°-14-200	14	200	63	36	27	E04
HSK63A-SF4.5°-16-95	16	95	63	38	27	E05
HSK63A-SF4.5°-16-120	16	120	63	36	27	E05
HSK63A-SF4.5°-16-160	16	160	63	36	27	E05
HSK63A-SF4.5°-16-200	16	200	63	36	27	E05
HSK63A-SF4.5°-18-95	18	95	63	44	33	E05
HSK63A-SF4.5°-18-160	18	160	63	44	33	E05
HSK63A-SF4.5°-18-200	18	200	63	44	33	E05

For shanks with tolerance h6 or better

E01	12087062
E02	12087063
E03	12087064
E04	12087065
E05	12087066

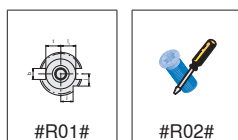

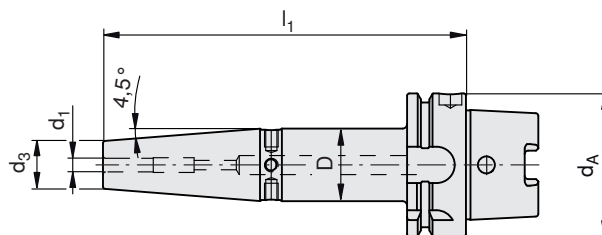
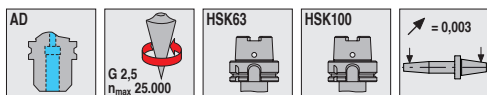

Type, description	d ₁ [mm]	l ₁ [mm]	d _A [mm]	D [mm]	d ₃ [mm]	
HSK63A-SF4.5°-20-100	20	100	63	45	33	E01
HSK63A-SF4.5°-20-160	20	160	63	44	33	E01
HSK63A-SF4.5°-20-200	20	200	63	44	33	E01
HSK63A-SF4.5°-25-115	25	115	63	53	44	E01
HSK63A-SF4.5°-25-160	25	160	63	53	44	E01
HSK63A-SF4.5°-25-200	25	200	63	53	44	E01
HSK63A-SF4.5°-32-120	32	120	63	53	44	E01
HSK63A-SF4.5°-32-160	32	160	63	53	44	E01
HSK63A-SF4.5°-32-200	32	200	63	53	44	E01
HSK100A-SF4.5°-6-85	6	85	100	30	21	E02
HSK100A-SF4.5°-6-120	6	120	100	32	21	E02
HSK100A-SF4.5°-6-160	6	160	100	32	21	E02
HSK100A-SF4.5°-6-200	6	200	100	32	21	E02
HSK100A-SF4.5°-8-85	8	85	100	30	21	E03
HSK100A-SF4.5°-8-120	8	120	100	32	21	E03
HSK100A-SF4.5°-8-160	8	160	100	32	21	E03
HSK100A-SF4.5°-8-200	8	200	100	32	21	E03
HSK100A-SF4.5°-10-90	10	90	100	34	24	E04
HSK100A-SF4.5°-10-120	10	120	100	34	24	E04
HSK100A-SF4.5°-10-160	10	160	100	34	24	E04
HSK100A-SF4.5°-10-200	10	200	100	34	24	E04
HSK100A-SF4.5°-12-95	12	95	100	35	24	E05
HSK100A-SF4.5°-12-120	12	120	100	34	24	E05
HSK100A-SF4.5°-12-160	12	160	100	34	24	E05
HSK100A-SF4.5°-12-200	12	200	100	34	24	E05
HSK100A-SF4.5°-14-95	14	95	100	38	27	E05
HSK100A-SF4.5°-14-120	14	120	100	36	27	E05
HSK100A-SF4.5°-14-160	14	160	100	36	27	E05
HSK100A-SF4.5°-14-200	14	200	100	36	27	E05
HSK100A-SF4.5°-16-100	16	100	100	39	27	E06
HSK100A-SF4.5°-16-160	16	160	100	36	27	E06
HSK100A-SF4.5°-16-200	16	200	100	36	27	E06
HSK100A-SF4.5°-18-100	18	100	100	45	33	E06
HSK100A-SF4.5°-18-160	18	160	100	44	33	E06
HSK100A-SF4.5°-18-200	18	200	100	44	33	E06

For shanks with tolerance h6 or better

E01	12087067
E02	12087062
E03	12087063
E04	12087064
E05	12087065
E06	12087066

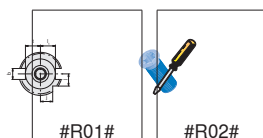

HSK-A

Shrink fit adapters

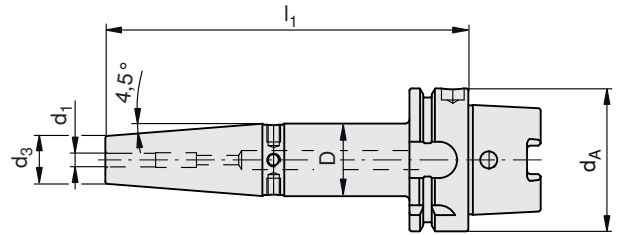

Type, description	d ₁ [mm]	l ₁ [mm]	d _A [mm]	D [mm]	d ₃ [mm]	
HSK100A-SF4.5°-20-105	20	105	100	45	33	E01
HSK100A-SF4.5°-20-160	20	160	100	44	33	E01
HSK100A-SF4.5°-20-200	20	200	100	44	33	E01
HSK100A-SF4.5°-25-115	25	115	100	53	44	E01
HSK100A-SF4.5°-25-160	25	160	100	53	44	E01
HSK100A-SF4.5°-25-200	25	200	100	53	44	E01
HSK100A-SF4.5°-32-120	32	120	100	59	44	E01
HSK100A-SF4.5°-32-160	32	160	100	53	44	E01
HSK100A-SF4.5°-32-200	32	200	100	53	44	E01

For shanks with tolerance h6 or better

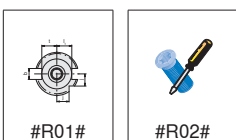
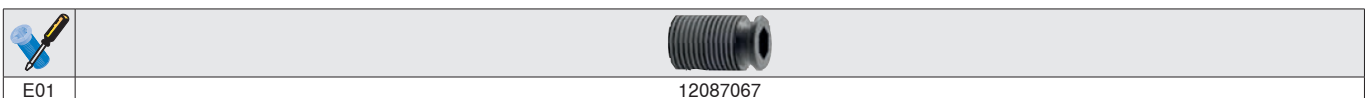

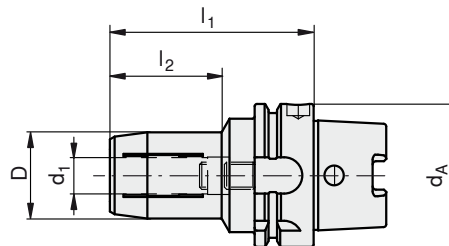

Type, description	d ₁ [mm]	l ₁ [mm]	l ₂ [mm]	d _A [mm]	D [mm]
HSK63A-HD06-70	6	70	26	63	26
HSK63A-HD06-150	6	150	105	63	26
HSK63A-HD06-200	6	200	155	63	26
HSK63A-HD08-70	8	70	26	63	28
HSK63A-HD08-150	8	150	105	63	28
HSK63A-HD08-200	8	200	155	63	28
HSK63A-HD10-80	10	80	35	63	30
HSK63A-HD10-150	10	150	105	63	30
HSK63A-HD10-200	10	200	155	63	30
HSK63A-HD12-85	12	85	40	63	32
HSK63A-HD12-150	12	150	105	63	32
HSK63A-HD12-200	12	200	155	63	32
HSK63A-HD14-85	14	85	40	63	34
HSK63A-HD14-150	14	150	105	63	34
HSK63A-HD14-200	14	200	155	63	34
HSK63A-HD16-90	16	90	46	63	38
HSK63A-HD16-150	16	150	105	63	38
HSK63A-HD16-200	16	200	155	63	38
HSK63A-HD18-90	18	90	46	63	40
HSK63A-HD18-150	18	150	105	63	40
HSK63A-HD18-200	18	200	155	63	40
HSK63A-HD20-90	20	90	46	63	42
HSK63A-HD20-150	20	150	105	63	42
HSK63A-HD20-200	20	200	155	63	42
HSK63A-HD25-120	25	120	52	63	53
HSK63A-HD32-125	32	125	99	63	60
HSK100A-HD06-75	6	75	26	100	26
HSK100A-HD08-75	8	75	26	100	28
HSK100A-HD10-90	10	90	40	100	30
HSK100A-HD12-95	12	95	40	100	32
HSK100A-HD14-95	14	95	40	100	34
HSK100A-HD16-100	16	100	46	100	38
HSK100A-HD18-100	18	100	46	100	40
HSK100A-HD20-105	20	105	46	100	42
HSK100A-HD25-115	25	115	86	100	57
HSK100A-HD32-120	32	120	91	100	64

⚠ For tools with shank to DIN 1835 A+B and DIN 6535 HA+HB
Shank to DIN 6535 HE in connection with reduction sleeves

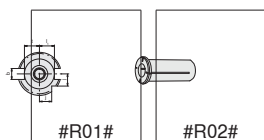



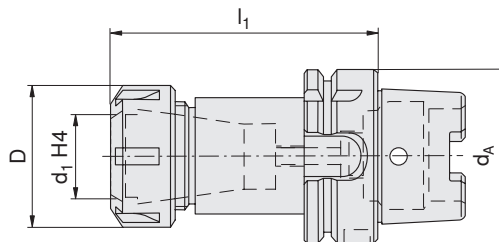
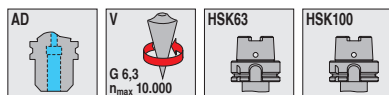

HSK-A

Collet chucks type ER



Type, description	d ₁ [mm]	l ₁ [mm]	d _A [mm]	D [mm]	
HSK63A-ER16-100-V	16	100	63	28	E01
HSK63A-ER16-160-V	16	160	63	28	E01
HSK63A-ER20-103-V	20	103	63	35	E02
HSK63A-ER25-103-V	25	103	63	42	E03
HSK63A-ER25-160-V	25	160	63	42	E03
HSK63A-ER32-103-V	32	103	63	50	E04
HSK63A-ER40-120-V	40	120	63	63	E05
HSK100A-ER16-100-V	16	100	100	32	E06
HSK100A-ER16-160-V	16	160	100	32	E06
HSK100A-ER20-103-V	20	103	100	35	E07
HSK100A-ER25-103-V	25	103	100	42	E08
HSK100A-ER25-160-V	25	160	100	42	E08
HSK100A-ER32-103-V	32	103	100	50	E09
HSK100A-ER40-120-V	40	120	100	63	E10

				
E01	6295005400	8376006300	11154410	8335711600
E02	6295004500	8376006300	11154413	
E03	6295005500	8376006300	11154414	8335712500
E04	6295005600	8376006300	11154418	8335713200
E05	6295005700	8376006300	11154419	8335714000
E06	6295005400	8376010000	11154410	8335711600
E07	6295004500	8376010000	11154413	
E08	6295005500	8376010000	11154414	8335712500
E09	6295005600	8376010000	11154418	8335713200
E10	6295005700	8376010000	11154419	8335714000



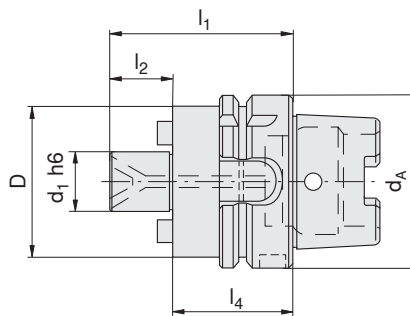
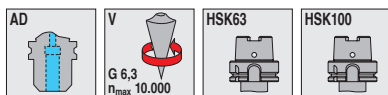

Type, description	d ₁ [mm]	d _A [mm]	D [mm]	l ₁ [mm]	l ₂ [mm]	l ₄ [mm]	
HSK63A-QA16-50-V	16	63	40	67	17	50	E01
HSK63A-QA22-50-V	22	63	50	69	19	50	E02
HSK63A-QA27-60-V	27	63	60	81	21	60	E03
HSK63A-QA32-60-V	32	63	78	84	24	60	E04
HSK63A-QA40-60-V	40	63	89	87	27	60	E05
HSK100A-QA16-50-V	16	100	40	67	17	50	E06
HSK100A-QA22-50-V	22	100	50	69	19	50	E07
HSK100A-QA27-50-V	27	100	60	71	21	50	E08
HSK100A-QA32-50-V	32	100	78	74	24	50	E09
HSK100A-QA40-60-V	40	100	89	87	27	60	E10
HSK100A-QA60-70-V	60	100	129	110	40	70	E11

E01	8395012000	8376006300	8395029600		8336701600
E02	8395012100	8376006300	8395029700		8336702200
E03	8395012200	8376006300	8395013600		8336702700
E04	8395012300	8376006300	8395013700		8336703200
E05	8395029500	8376006300	8395013800	8395014000	8336704000
E06	8395012000	8376010000	8395029600		8336701600
E07	8395012100	8376010000	8395029700		8336702200
E08	8395012200	8376010000	8395013600		8336702700
E09	8395012300	8376010000	8395013700		8336703200
E10	8395029500	8376010000	8395013800	8395014000	8336704000
E11	8395029800	8376010000		8395016000 / 8395012500	

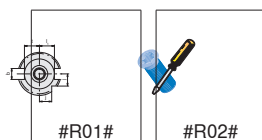

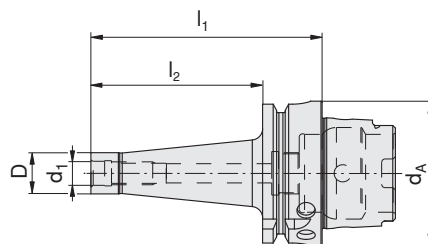
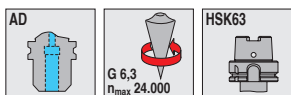

HSK-A

Adapters for threaded shank milling cutters



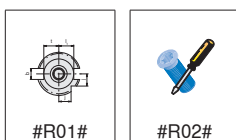

Type, description	d ₁ [mm]	l ₁ [mm]	l ₂ [mm]	d _A [mm]	D [mm]	
HSK-A63-M8-50	8	76	50	63	23	E01
HSK-A63-M8-75	8	101	75	63	25	E01
HSK-A63-M8-100	8	126	100	63	30	E01
HSK-A63-M10-50	10	76	50	63	25	E01
HSK-A63-M10-75	10	101	75	63	30	E01
HSK-A63-M10-100	10	126	100	63	35	E01
HSK-A63-M12-50	12	76	50	63	30	E01
HSK-A63-M12-75	12	101	75	63	35	E01
HSK-A63-M12-100	12	126	100	63	38	E01
HSK-A63-M16-50	16	76	50	63	34	E01
HSK-A63-M16-75	16	101	75	63	35	E01
HSK-A63-M16-100	16	126	100	63	40	E01

	
E01	8376006300

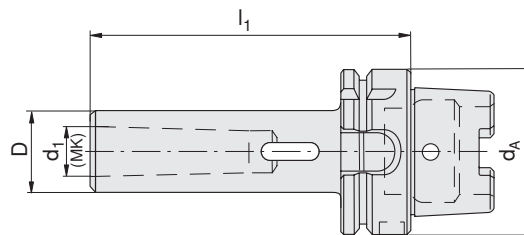
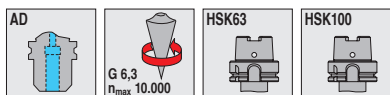



Type, description	d ₁ Morse taper [MK]	l ₁ [mm]	d _A [mm]	D [mm]	
HSK63A-MK1D-100	1	100	63	25	E01
HSK63A-MK2D-120	2	120	63	32	E01
HSK63A-MK3D-140	3	140	63	40	E01
HSK63A-MK4D-160	4	160	63	48	E01
HSK100A-MK1D-110	1	110	100	25	E02
HSK100A-MK2D-120	2	120	100	32	E02
HSK100A-MK3D-150	3	150	100	40	E02
HSK100A-MK4D-170	4	170	100	48	E02
HSK100A-MK5D-200	5	200	100	63	E02

	
E01	8376006300
E02	8376010000

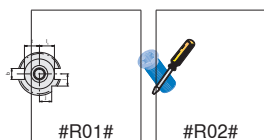

HSK-A

PSC adapters

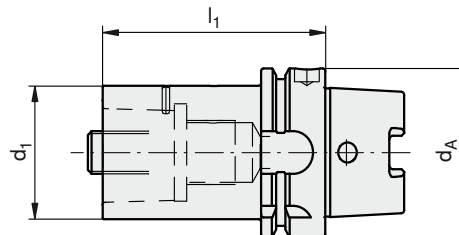
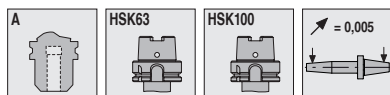

Type, description	d_1 [mm]	l_1 [mm]	d_A [mm]	D [mm]	Torque moment [Nm]
HSK63A-PSC50	50	90	63	50	--
HSK100A-PSC50	50	100	100	50	--
HSK100A-PSC63	63	110	100	63	--

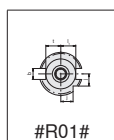

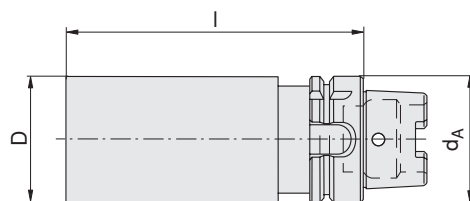
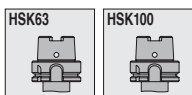

Type, description	d_A [mm]	D [mm]	l [mm]
HSK63A-HF63-200	63	63	200
HSK100A-HF100-250	100	100	250



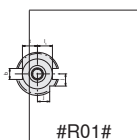

Type, description	d_A [mm]	D [mm]	l [mm]
HSK63A-KD40-346	63	63	346
HSK100A-KD40-349	100	40	349



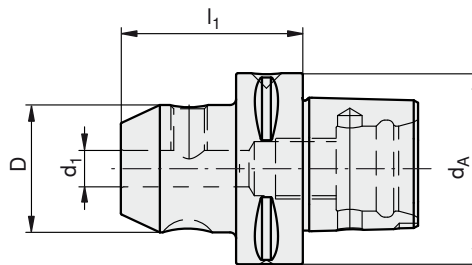
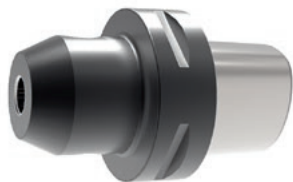
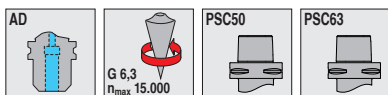

PSC

Weldon adapters



Type, description	d ₁ [mm]	l ₁ [mm]	d _A [mm]	D [mm]	
PSC50-WE06-50	6	50	50	25	E01
PSC50-WE08-50	8	50	50	28	E02
PSC50-WE10-55	10	55	50	35	E02
PSC50-WE12-60	12	60	50	42	E03
PSC50-WE14-60	14	60	50	44	E03
PSC50-WE16-60	16	60	50	48	E04
PSC50-WE18-60	18	60	50	50	E05
PSC50-WE20-60	20	60	50	52	E06
PSC50-WE25-80	25	80	50	65	E05
PSC63-WE06-55	6	55	63	25	E01
PSC63-WE08-55	8	55	63	28	E02
PSC63-WE10-60	10	60	63	35	E02
PSC63-WE12-60	12	60	63	42	E03
PSC63-WE14-60	14	60	63	44	E03
PSC63-WE16-65	16	65	63	48	E04
PSC63-WE18-65	18	65	63	50	E05
PSC63-WE20-65	20	65	63	52	E06
PSC63-WE25-80	25	80	63	65	E05
PSC63-WE32-90	32	90	63	72	E06
PSC63-WE40-100	40	100	63	80	E06

	
E01	6295001000
E02	6295001200
E03	6295001600
E04	6295002000
E05	6295002500
E06	6295003200

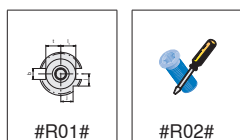

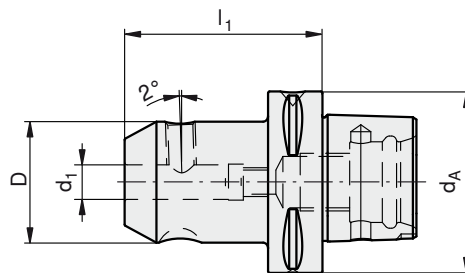
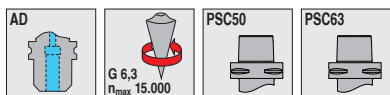

Type, description	d ₁ [mm]	l ₁ [mm]	d _A [mm]	D [mm]	
PSC50-WN06-70	6	70	50	25	E01
PSC50-WN08-70	8	70	50	28	E02
PSC50-WN10-70	10	70	50	35	E02
PSC50-WN12-75	12	75	50	42	E03
PSC50-WN14-75	14	75	50	44	E03
PSC50-WN16-80	16	80	50	48	E04
PSC50-WN18-80	18	80	50	50	E05
PSC50-WN20-85	20	85	50	52	E06
PSC63-WN06-75	6	75	63	25	E01
PSC63-WN08-75	8	75	63	28	E02
PSC63-WN10-75	10	75	63	35	E02
PSC63-WN12-80	12	80	63	42	E03
PSC63-WN14-80	14	80	63	44	E03
PSC63-WN16-80	16	80	63	48	E04
PSC63-WN18-80	18	80	63	50	E05
PSC63-WN20-85	20	85	63	52	E06
PSC63-WN25-90	25	90	63	58	E05
PSC63-WN32-95	32	95	63	61	E06

E01	6295001000
E02	6295001200
E03	6295001600
E04	6295002000
E05	6295002500
E06	6295003200

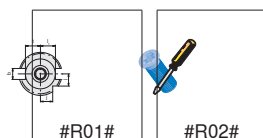

PSC

Shrink fit adapters

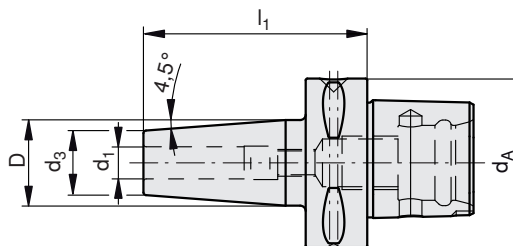
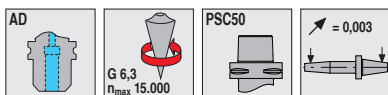

Type, description	d ₁ [mm]	l ₁ [mm]	d _A [mm]	D [mm]	d ₃ [mm]	
PSC50-SF4.5°-3-65	3	65	50	17	12	
PSC50-SF4.5°-4-65	4	65	50	17	12	
PSC50-SF4.5°-5-65	5	65	50	17	12	
PSC50-SF4.5°-6-75	6	75	50	29.7	21	E01
PSC50-SF4.5°-6-120	6	120	50	32	21	E01
PSC50-SF4.5°-8-75	8	75	50	29.7	21	E02
PSC50-SF4.5°-8-120	8	120	50	32	21	E02
PSC50-SF4.5°-10-75	10	75	50	32.7	24	E03
PSC50-SF4.5°-10-120	10	120	50	34	24	E03
PSC50-SF4.5°-12-75	12	75	50	32.7	24	E04
PSC50-SF4.5°-12-120	12	120	50	34	24	E04
PSC50-SF4.5°-14-80	14	80	50	34	27	E04
PSC50-SF4.5°-14-120	14	120	50	36	27	E04
PSC50-SF4.5°-16-80	16	80	50	34	27	E05
PSC50-SF4.5°-16-120	16	120	50	36	27	E05
PSC50-SF4.5°-18-80	18	80	50	42	33	E05
PSC50-SF4.5°-18-120	18	120	50	42	33	E05
PSC50-SF4.5°-20-85	20	85	50	42	33	E06
PSC50-SF4.5°-20-120	20	120	50	42	33	E06
PSC50-SF4.5°-25-90	25	90	50	53	44	E06
PSC50-SF4.5°-25-120	25	120	50	53	44	E06

For shanks with tolerance h6 or better

E01	12087062
E02	12087063
E03	12087064
E04	12087065
E05	12087066
E06	12087067

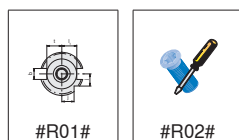

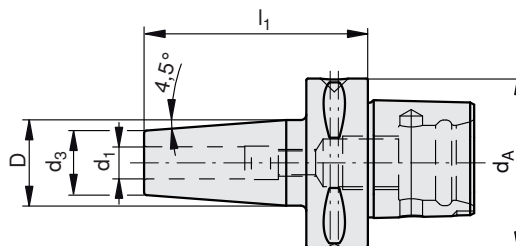
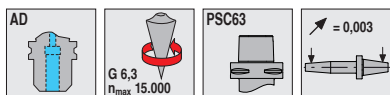

Type, description	d ₁ [mm]	l ₁ [mm]	d _A [mm]	D [mm]	d ₃ [mm]	
PSC63-SF4.5°-3-80	3	80	63	17	12	
PSC63-SF4.5°-4-80	4	80	63	17	12	
PSC63-SF4.5°-5-80	5	80	63	17	12	
PSC63-SF4.5°-6-80	6	80	63	27	21	E01
PSC63-SF4.5°-6-120	6	120	63	32	21	E01
PSC63-SF4.5°-6-160	6	160	63	32	21	E01
PSC63-SF4.5°-8-80	8	80	63	27	21	E02
PSC63-SF4.5°-8-120	8	120	63	32	21	E02
PSC63-SF4.5°-8-160	8	160	63	32	21	E02
PSC63-SF4.5°-10-80	10	80	63	32	24	E03
PSC63-SF4.5°-10-120	10	120	63	32	24	E03
PSC63-SF4.5°-10-160	10	160	63	34	24	E03
PSC63-SF4.5°-12-80	12	80	63	32	24	E04
PSC63-SF4.5°-12-120	12	120	63	32	24	E04
PSC63-SF4.5°-12-160	12	160	63	34	24	E04
PSC63-SF4.5°-14-85	14	85	63	34	27	E04
PSC63-SF4.5°-14-120	14	120	63	36	27	E04
PSC63-SF4.5°-14-160	14	160	63	36	27	E04
PSC63-SF4.5°-16-85	16	85	63	34	27	E05
PSC63-SF4.5°-16-120	16	120	63	36	27	E05
PSC63-SF4.5°-16-160	16	160	63	36	27	E05
PSC63-SF4.5°-18-85	18	85	63	42	33	E05
PSC63-SF4.5°-18-120	18	120	63	44	33	E05
PSC63-SF4.5°-18-160	18	160	63	44	33	E05
PSC63-SF4.5°-20-85	20	85	63	42	33	E06
PSC63-SF4.5°-20-120	20	120	63	44	33	E06
PSC63-SF4.5°-20-160	20	160	63	44	33	E06
PSC63-SF4.5°-25-90	25	90	63	52.5	44	E06
PSC63-SF4.5°-25-120	25	120	63	52.5	44	E06
PSC63-SF4.5°-25-160	25	160	63	52.5	44	E06
PSC63-SF4.5°-32-95	32	95	63	52.5	44	
PSC63-SF4.5°-32-120	32	120	63	52.5	44	E06
PSC63-SF4.5°-32-160	32	160	63	52.5	44	E06

For shanks with tolerance h6 or better

E01	12087062
E02	12087063
E03	12087064
E04	12087065
E05	12087066
E06	12087067

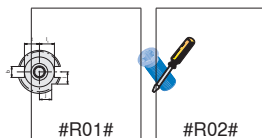

PSC

Hydraulic expansion chucks

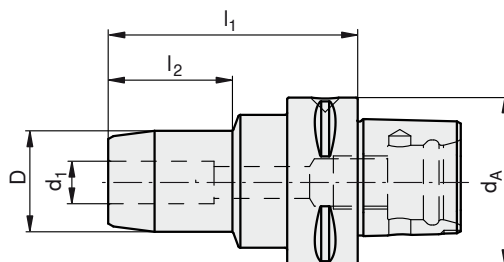
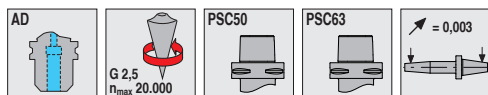

Type, description	d ₁ [mm]	l ₁ [mm]	l ₂ [mm]	d _A [mm]	D [mm]
PSC50-HD06-65	6	65	30	50	26
PSC50-HD08-65	8	65	30	50	28
PSC50-HD10-75	10	75	40	50	30
PSC50-HD12-80	12	80	40	50	32
PSC50-HD14-80	14	80	40	50	34
PSC50-HD16-85	16	85	46	50	38
PSC50-HD18-85	18	85	46	50	40
PSC50-HD20-85	20	85	46	50	42
PSC63-HD06-65	6	65	25	63	26
PSC63-HD08-65	8	65	25	63	28
PSC63-HD10-75	10	75	35	63	30
PSC63-HD12-80	12	80	40	63	32
PSC63-HD14-80	14	80	40	63	34
PSC63-HD16-85	16	85	46	63	38
PSC63-HD18-85	18	85	46	63	40
PSC63-HD20-85	20	85	46	63	42
PSC63-HD25-95	25	95	73	63	55
PSC63-HD32-100	32	100	78	63	63

⚠ For tools with shank to DIN 1835 A+B and DIN 6535 HA+HB
 Shank to DIN 6535 HE in connection with reduction sleeves

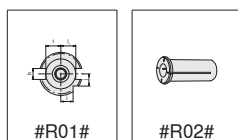

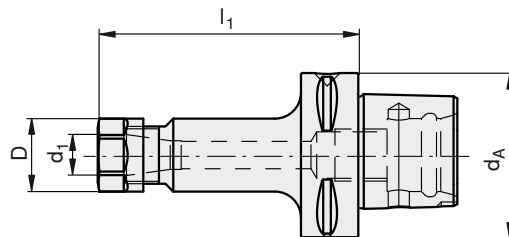
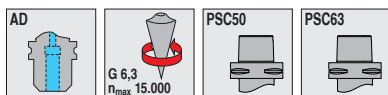

Type, description	d ₁ [mm]	l ₁ [mm]	d _A [mm]	D [mm]	
PSC50-ER16-60	16	60	50	28	E01
PSC50-ER16-100	16	100	50	28	E01
PSC50-ER20-60	20	60	50	34	E02
PSC50-ER20-100	20	100	50	34	E02
PSC50-ER25-60	25	60	50	42	E03
PSC50-ER25-100	25	100	50	42	E03
PSC50-ER32-60	32	60	50	50	E04
PSC50-ER32-100	32	100	50	50	E04
PSC50-ER40-65	40	65	50	63	E05
PSC50-ER40-100	40	100	50	63	E05
PSC63-ER20-60	20	60	63	34	E02
PSC63-ER20-100	20	100	63	34	E02
PSC63-ER25-60	25	60	63	42	E03
PSC63-ER25-100	25	100	63	42	E03
PSC63-ER32-60	32	60	63	50	E04
PSC63-ER32-100	32	100	63	50	E04
PSC63-ER40-65	40	65	63	63	E05
PSC63-ER40-100	40	100	63	63	E05

E01	6295005400	8335711600
E02	6295004500	
E03	6295005500	8335712500
E04	6295005600	8335713200
E05	6295005700	8335714000

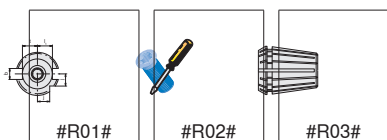

PSC

Combination shell mill adapters

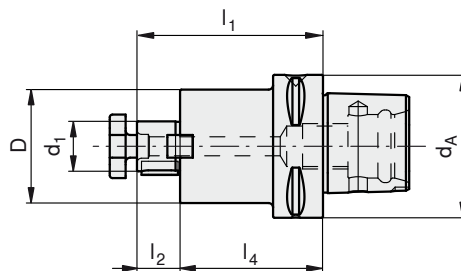
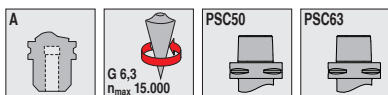

Type, description	d ₁ [mm]	d _A [mm]	D [mm]	l ₁ [mm]	l ₂ [mm]	l ₄ [mm]	
PSC50-KA16-28	16	50	40	45	17	28	E01
PSC50-KA16-63	16	50	40	80	17	63	E01
PSC50-KA22-28	22	50	50	47	19	28	E02
PSC50-KA22-63	22	50	50	82	19	63	E02
PSC50-KA27-32	27	50	58	53	21	32	E03
PSC50-KA27-63	27	50	58	84	21	63	E03
PSC50-KA32-40	32	50	63	64	24	40	E04
PSC50-KA32-63	32	50	63	87	24	63	E04
PSC63-KA16-63	16	63	40	80	17	63	E01
PSC63-KA22-28	22	63	63	47	19	28	E02
PSC63-KA22-63	22	63	50	82	19	63	E02
PSC63-KA27-28	27	63	58	49	21	28	E03
PSC63-KA27-63	27	63	58	84	21	63	E03
PSC63-KA32-22	32	63	63	46	24	22	E04
PSC63-KA32-86	32	63	63	110	24	86	E04
PSC63-KA40-40	40	63	70	67	27	40	E05

E01	12087073	12087068	8395011300	8336701600	8336811600
E02	12087074	12087069	8395012400	8336702200	8336812200
E03	12087075	12087070	8395012500	8336702700	8336812700
E04	12087076	12087071	8395012600	8336703200	8336813200
E05	12087077	12087072	8395011200	8336704000	8336814000

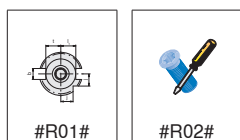

Adapters with threaded shank / Morse taper adapters with thread

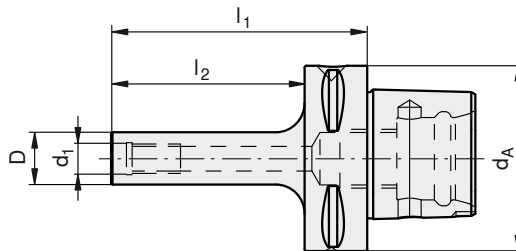
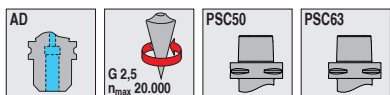

Type, description	d ₁ [mm]	l ₁ [mm]	l ₂ [mm]	d _A [mm]	D [mm]
PSC50-M8-70	8	70	50	50	13
PSC50-M10-80	10	80	60	50	18
PSC50-M12-80	12	80	60	50	21
PSC50-M16-80	16	80	60	50	29
PSC63-M8-70	8	70	48	63	13
PSC63-M10-90	10	90	68	63	18
PSC63-M12-100	12	100	78	63	21
PSC63-M16-100	16	100	78	63	29

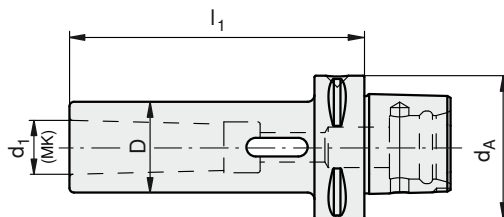
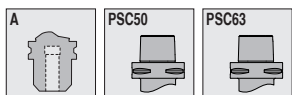

Type, description	d ₁ Morse taper [MK]	l ₁ [mm]	d _A [mm]	D [mm]
PSC50-MK2-110	2	110	50	32
PSC50-MK3-130	3	130	50	40
PSC50-MK4-150	4	150	50	48
PSC63-MK2-110	2	110	63	32
PSC63-MK3-130	3	130	63	40
PSC63-MK4-150	4	150	63	48

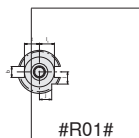

PSC

Blanks / Test bars

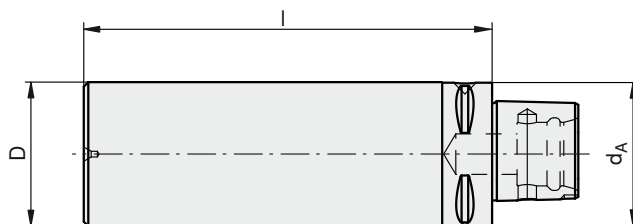
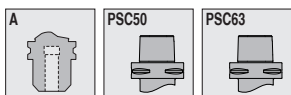

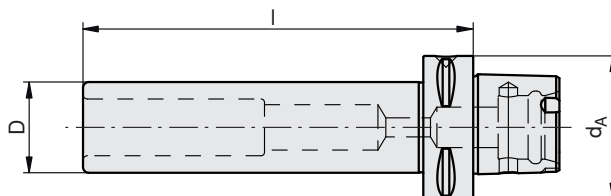
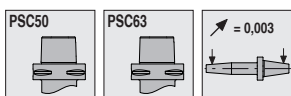

Type, description	d_A [mm]	D [mm]	l [mm]
PSC50-HF50-125	50	50	125
PSC50-HF50-150	50	50	150
PSC50-HF75-175	50	75	175
PSC50-HF90-80	50	90	80
PSC50-HF95-150	50	95	150
PSC50-HF110-90	50	110	90
PSC63-HF63-180	63	63	180
PSC63-HF75-195	63	75	195
PSC63-HF110-85	63	110	85
PSC63-HF120-180	63	120	180
PSC63-HF130-95	63	130	95



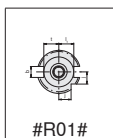

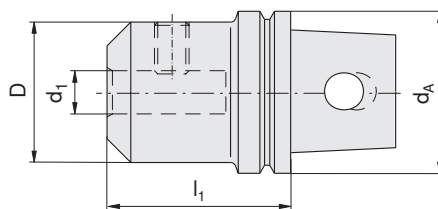
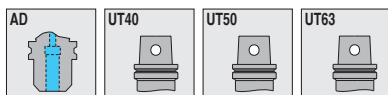

Type, description	d_A [mm]	D [mm]	l [mm]
PSC50-KD32-235	50	32	235
PSC63-KD40-322	63	40	322





Type, description	d ₁ [mm]	l ₁ [mm]	d _A [mm]	D [mm]	
UT40-AD-ZYL 08	8	45	40	28	E01
UT40-AD-ZYL 12	12	55	40	42	E02
UT40-AD-ZYL 16	16	60	40	48	E03
UT40-AD-ZYL 20	20	65	40	52	E04
UT40-AD-ZYL 25	25	75	40	65	E05
UT50-AD-ZYL 20	20	60	50	52	E06
UT63-WE06-80-MIY	6	80	63	25	E07
UT63-WE08-80-MIY	8	80	63	28	E08
UT63-WE10-80-MIY	10	80	63	35	E09
UT63-WE12-80-MIY	12	80	63	42	E10
UT63-WE14-80-MIY	14	80	63	44	E10
UT63-WE16-80-MIY	16	80	63	48	E11
UT63-WE18-80-MIY	18	80	63	50	E11
UT63-WE20-80-MIY	20	80	63	52	E12
UT63-WE25-80-MIY	25	80	63	65	E13
UT63-WE32-85-MIY	32	80	63	72	E14
UT63-AD-ZYL 32	32	85	63	70	E14
UT63-WE40-95-MIY	40	95	63	63	E15
UT63-AD-ZYL 40	40	100	63	90	E15

			
E01	8395003400	6295000800	194263
E02	8395003600	6295001200	194263
E03	8395003700	6295001600	194263
E04	8395027200	6295002000	194263
E05	8395029000	6295002500	194263
E06	8395027200	6295002000	225429
E07	8395003300	6295000600	225430
E08	8395003400	6295000800	225430
E09	8395003500	6295001000	225430
E10	8395003600	6295001200	225430
E11	8395003700	6295001600	225430
E12	8395027200	6295002000	225430
E13	8395029000	6295002500	225430
E14	8395029000	6295003200	225430
E15		6295003200	225430

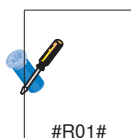

UTS

Whistle Notch adapters

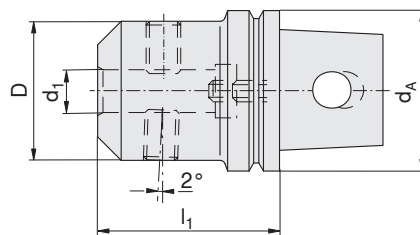
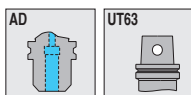





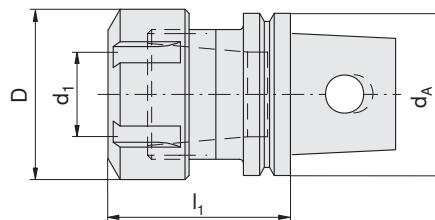
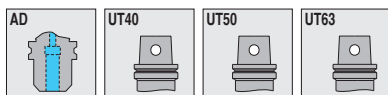

Type, description	d ₁ [mm]	l ₁ [mm]	d _A [mm]	D [mm]	
UT63-WEWN06-80-MIY	6	80	63	25	E01
UT63-WEWN08-80-MIY	8	80	63	28	E02
UT63-WEWN10-80-MIY	10	80	63	35	E03
UT63-WEWN12-80-MIY	12	80	63	42	E04
UT63-WEWN14-80-MIY	14	80	63	44	E04
UT63-WEWN16-80-MIY	16	80	63	48	E05
UT63-WEWN18-80-MIY	18	80	63	50	E05
UT63-WEWN20-80-MIY	20	80	63	52	E06
UT63-WEWN25-80-MIY	25	80	63	65	E07
UT63-WEWN32-80-MIY	32	80	63	72	E08
UT63-WEWN40-95-MIY	40	95	63	80	E09

E01	8395003300	6295000600	225430
E02	8395003400	6295000800	225430
E03	8395003500	6295001000	225430
E04	8395003600	6295001200	225430
E05	8395003700	6295001600	225430
E06	8395027200	6295002000	225430
E07	8395029000	6295002500	225430
E08	8395029000	6295003200	225430
E09		6295003200	225430



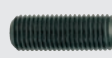

Type, description	d ₁ [mm]	l ₁ [mm]	d _A [mm]	D [mm]	
UT40-ER16-38	16	38	40	32	E01
UT40-ER25-45	25	45	40	42	E02
UT40-ER32-51	32	51	40	50	E03
UT50-ER32-51	32	51	50	50	E04
UT63-ER16-90-MIY	16	90	63	32	E05
UT63-ER16-120-MIY	16	120	63	32	E05
UT63-ER25-90-MIY	25	90	63	42	E06
UT63-ER25-120-MIY	25	120	63	42	E06
UT63-ER32-90-MIY	32	90	63	50	E07
UT63-ER40-80-MIY	40	80	63	63	E08

					
E01	6295005400			194263	8335711600
E02	6295005500	8395001000		194263	8335712500
E03	6295005600	8395001000		194263	8335713200
E04	6295005600	8395001000		225429	8335713200
E05	6295005400			225430	8335711600
E06	6295005500	8395001000		225430	8335712500
E07		8395029000	6295003200	225430	
E08			6295003200	225430	

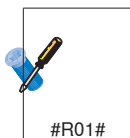

UTS

Shell mill adapters, centre bolt

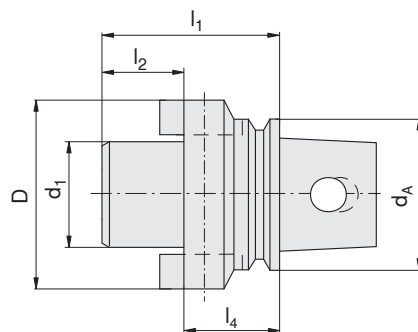
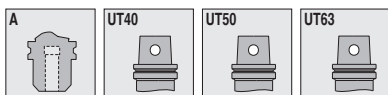

Type, description	d ₁ [mm]	d _A [mm]	D [mm]	l ₁ [mm]	l ₂ [mm]	l ₄ [mm]	
UT40-QA16-25IK	16	40	38	42	17	25	E01
UT40-QA22-25IK	22	40	46	44	19	25	E02
UT50-QA22-27IK	22	50	48	46	19	27	E03
UT50-QA32-35IK	32	50	78	59	24	35	E04
UT63-QA16-28-MIY	16	63	38	44	17	28	E05
UT63-QA16-110-MIY	16	63	38	127	17	110	E05
UT63-QA22-36-MIY	22	63	50	46	19	36	E06
UT63-QA22-110-MIY	22	63	50	129	19	110	E06
UT63-QA27-36-MIY	27	63	58	57	21	36	E07
UT63-QA27-36IK	27	63	58	57	21	36	E07
UT63-QA27-110-MIY	27	63	58	131	21	110	E07
UT63-QA32-33-MIY	32	63	78	57	24	33	E08
UT63-QA40-56IK	40	63	88	83	27	56	E09

E01	8395012000	8395029600	333935		194263
E02	8395012100	11210254	333937		194263
E03	8395012100	11210254	333937		225429
E04	8395012300	8395013700	333945		225429
E05	8395012000	8395029600	333935		225430
E06	8395012100	11210254	333937		225430
E07	8395012200	8395013600	333940		225430
E08	8395012300	8395013700	333945		225430
E09	8395029500	8395013800		8336704000	225430





HSK-T

Tool holders 0° / Tool holders 45°

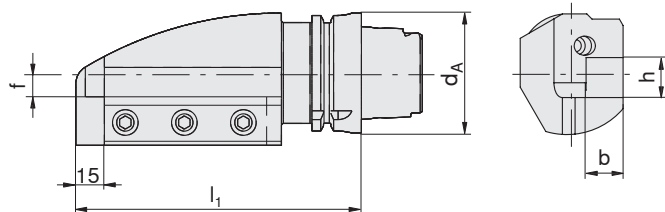
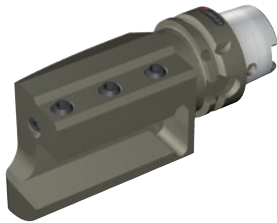
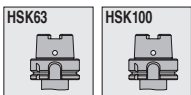

Type, description	d _A [mm]	l ₁ [mm]	f [mm]	b [mm]	h [mm]	
HSK-T63-SHL00-2525	63	150	13	25	25	E01
HSK-T63-SHR00-2525	63	150	13	25	25	E01
HSK-T100-SHR00-3232	100	160	15	32	32	E01
HSK-T100-SHL00-3232	100	160	15	32	32	E01

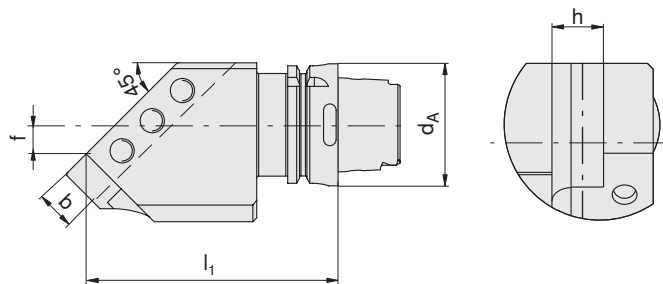
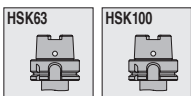

Type, description	d _A [mm]	l ₁ [mm]	f [mm]	b [mm]	h [mm]	
HSK-T63-SHL45-2525	63	130	15	25	25	E01
HSK-T63-SHR45-2525	63	130	15	25	25	E01
HSK-T100-SHL45-3232	100	160	20	32	32	E01
HSK-T100-SHR45-3232	100	160	20	32	32	E01

E01	12001280	11960178	11848510	11106932

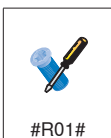

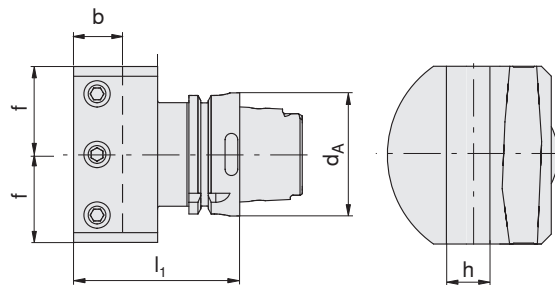
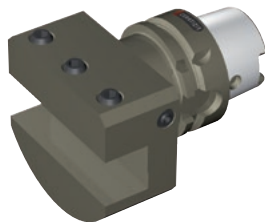
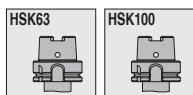

Type, description	d _A [mm]	l ₁ [mm]	f [mm]	b [mm]	h [mm]	
HSK-T63-SHN90-2525	63	85	45	25	25	E01
HSK-T100-SHN90-3232	100	90	50	32	32	E01

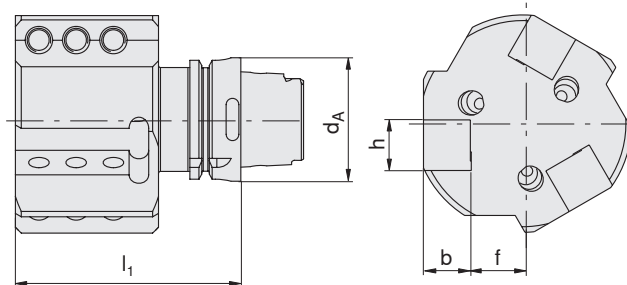
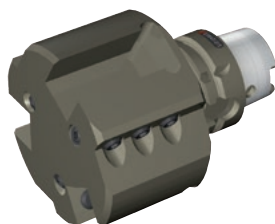
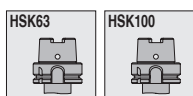

Type, description	d _A [mm]	l ₁ [mm]	f [mm]	b [mm]	h [mm]	
HSK-T63-SH3L00-2525	63	115	28	25	25	E01
HSK-T100-SH3L00-2525	100	120	33	25	25	E01

E01	12001280	11960178	11848510	11106932	

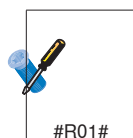

HSK-T

Boring bar holders / Extensions

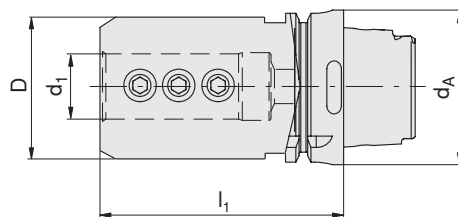
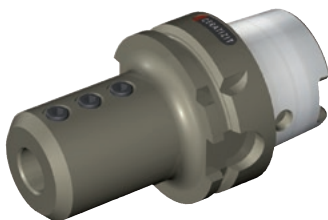
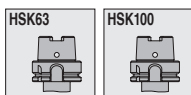

Type, description	d ₁ [mm]	l ₁ [mm]	d _A [mm]	D [mm]
HSK-T63-BH08-80	8	80	63	32
HSK-T63-BH10-80	10	80	63	40
HSK-T63-BH12-80	12	80	63	40
HSK-T63-BH16-80	16	80	63	40
HSK-T63-BH20-80	20	80	63	50
HSK-T63-BH25-90	25	90	63	52.6
HSK-T63-BH32-95	32	95	63	68
HSK-T100-BH20-90	20	90	100	55
HSK-T100-BH25-95	25	95	100	55
HSK-T100-BH32-110	32	110	100	68
HSK-T100-BH40-120	40	120	100	83
HSK-T100-BH50-125	50	125	100	98

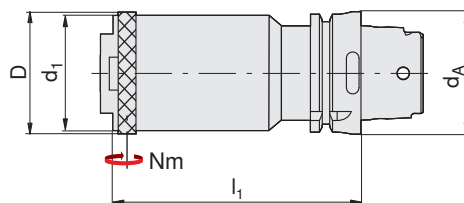
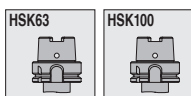

Type, description	d ₁ [mm]	l ₁ [mm]	d _A [mm]	D [mm]	Torque moment [Nm]
HSK-T63-V80	63	80	63	68	20
HSK-T63-V120	63	120	63	68	20
HSK-T100-V120	100	120	100	105	50

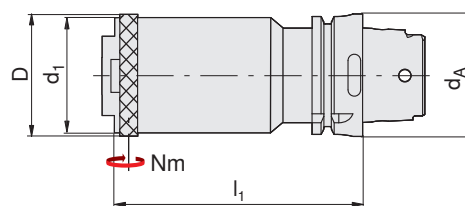

Type, description	d ₁ [mm]	l ₁ [mm]	d _A [mm]	D [mm]	Torque moment [Nm]
HSK-T100-R63-100	63	100	100	68	50

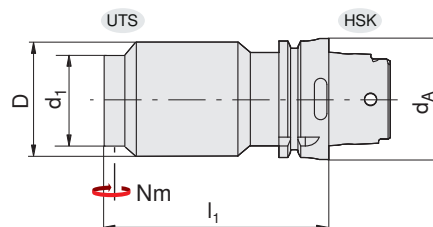

Type, description	d ₁ [mm]	l ₁ [mm]	d _A [mm]	D [mm]	Torque moment [Nm]
HSK-T63-UT40-80	40	80	63	48	16
HSK-T63-UT50-95	50	95	63	58	32
HSK-T63-UT63-105	63	105	63	72	50
HSK-T100-UT40-80	40	80	100	48	16
HSK-T100-UT50-100	50	100	100	58	32
HSK-T100-UT63-115	63	115	100	72	50

HSK-T

Blanks / Test bars

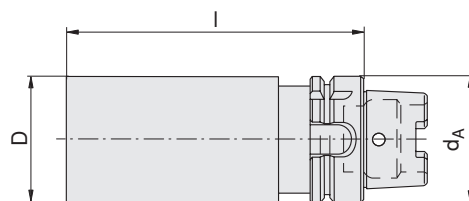
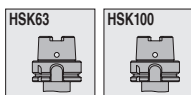

Type, description	d_A [mm]	D [mm]	I [mm]
HSK-T63-HF72-210	63	72	210
HSK-T63-HF90-90	63	90	90
HSK-T63-HF100-150	63	100	150
HSK-T100-HF100-250	100	100	250
HSK-T100-HF110-100	100	110	100
HSK-T100-HF120-160	100	120	160

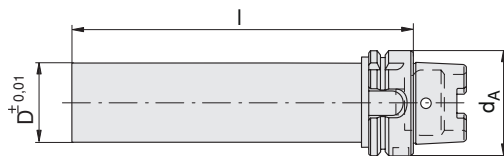
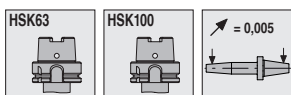

Type, description	d_A [mm]	D [mm]	I [mm]
HSK63A-KD40-346	63	63	346
HSK100A-KD40-349	100	40	349

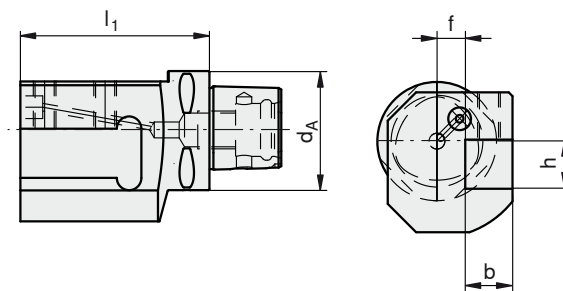
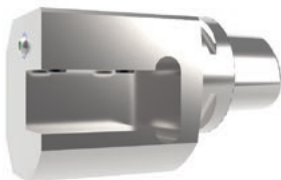
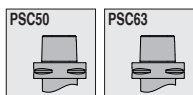

Type, description	d _A [mm]	l ₁ [mm]	f [mm]	b [mm]	h [mm]
PSC50-SHL00-2020	50	80	15	20	20
PSC50-SHR00-2020	50	80	15	20	20
PSC50-SHL00-2525	50	90	15	25	25
PSC50-SHR00-2525	50	90	15	25	25
PSC50-SHL00-3232	50	115	15	32	32
PSC50-SHR00-3232	50	115	15	32	32
PSC63-SHL00-2020	63	90	15	20	20
PSC63-SHR00-2020	63	90	15	20	20
PSC63-SHL00-2525	63	100	15	25	25
PSC63-SHR00-2525	63	100	15	25	25
PSC63-SHL00-3232	63	125	15	32	32
PSC63-SHR00-3232	63	125	15	32	32

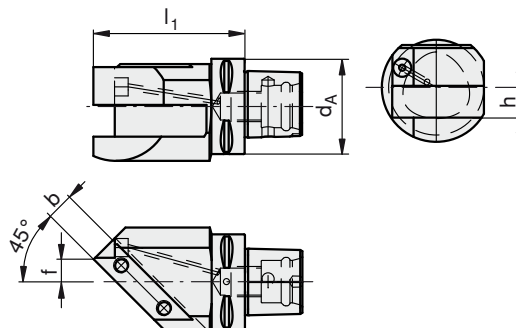
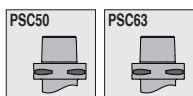

Type, description	d _A [mm]	l ₁ [mm]	f [mm]	b [mm]	h [mm]
PSC50-SHR45-2020	50	100	15	20	20
PSC50-SHL45-2020	50	100	15	20	20
PSC63-SHR45-2020	63	100	15	20	20
PSC63-SHL45-2020	63	100	15	20	20

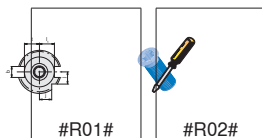

PSC

Tool holders 90° / Double tool holders

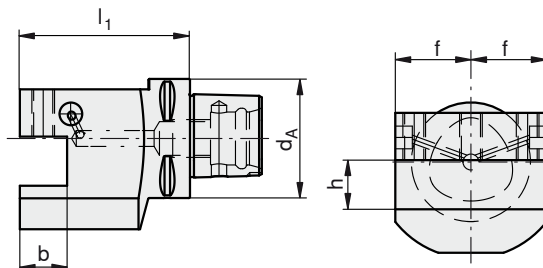
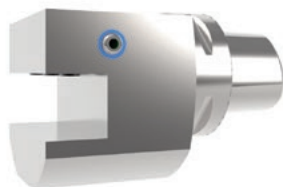
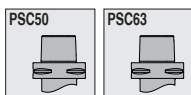

Type, description	d _A [mm]	l ₁ [mm]	f [mm]	b [mm]	h [mm]
PSC50-SHN90-2020	50	70	35	20	20
PSC50-SHN90-2525	50	80	40	25	25
PSC50-SHN90-3232	50	90	45	32	32
PSC63-SHN90-2020	63	80	35	20	20
PSC63-SHN90-2525	63	90	40	25	25
PSC63-SHN90-3232	63	100	45	32	32

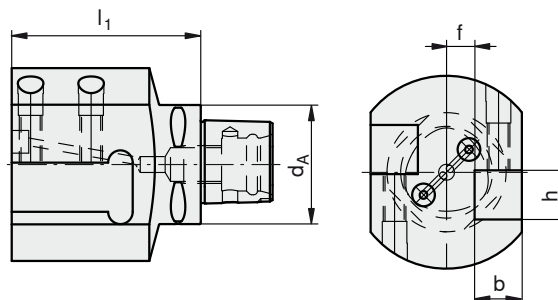
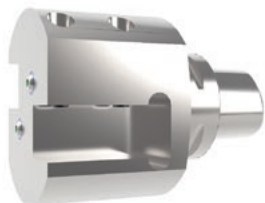
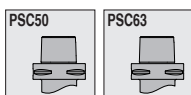

Type, description	d _A [mm]	l ₁ [mm]	f [mm]	b [mm]	h [mm]
PSC50-SH2L00-2020	50	80	15	20	20
PSC50-SH2R00-2020	50	80	15	20	20
PSC50-SH2L00-2525	50	90	15	25	25
PSC50-SH2R00-2525	50	90	15	25	25
PSC50-SH2L00-3232	50	115	15	32	32
PSC50-SH2R00-3232	50	115	15	32	32
PSC63-SH2L00-2020	63	90	15	20	20
PSC63-SH2R00-2020	63	90	15	20	20
PSC63-SH2L00-2525	63	100	15	25	25
PSC63-SH2R00-2525	63	100	15	25	25
PSC63-SH2L00-3232	63	125	15	32	32
PSC63-SH2R00-3232	63	125	15	32	32

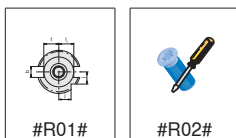

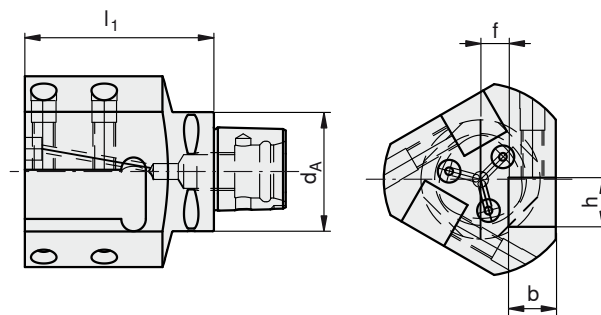
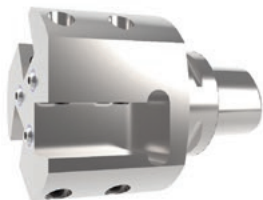
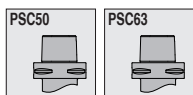

Type, description	d_A [mm]	l_1 [mm]	f [mm]	b [mm]	h [mm]
PSC50-SH3R00-2020	50	80	15	20	20
PSC50-SH3L00-2020	50	80	15	20	20
PSC50-SH3R00-2525	50	90	15	25	25
PSC50-SH3L00-2525	50	90	15	25	25
PSC50-SH3R00-3232	50	115	15	32	32
PSC50-SH3L00-3232	50	115	15	32	32
PSC63-SH3R00-2020	63	90	15	20	20
PSC63-SH3L00-2020	63	90	15	20	20
PSC63-SH3R00-2525	63	100	15	25	25
PSC63-SH3L00-2525	63	100	15	25	25
PSC63-SH3R00-3232	63	125	15	32	32
PSC63-SH3L00-3232	63	125	15	32	32

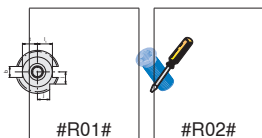

PSC

Boring bar holders

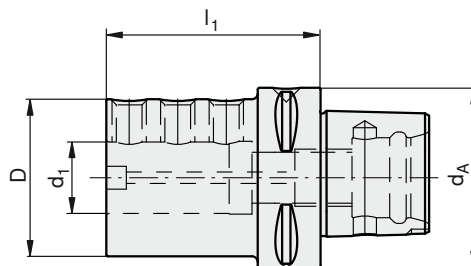
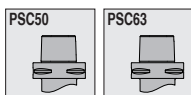

Type, description	d ₁ [mm]	l ₁ [mm]	d _A [mm]	D [mm]
PSC50-BH6-70	6	70	50	40
PSC50-BH8-70	8	70	50	44
PSC50-BH10-70	10	70	50	44
PSC50-BH12-70	12	70	50	44
PSC50-BH16-75	16	75	50	44
PSC50-BH20-75	20	75	50	50
PSC50-BH25-80	25	80	50	55
PSC50-BH32-90	32	90	50	72
PSC63-BH6-75	6	75	63	40
PSC63-BH6-80	6	80	63	40
PSC63-BH8-75	8	75	63	44
PSC63-BH8-85	8	85	63	45
PSC63-BH10-75	10	75	63	44
PSC63-BH10-85	10	85	63	50
PSC63-BH12-75	12	75	63	44
PSC63-BH12-100	12	100	63	63
PSC63-BH16-75	16	75	63	44
PSC63-BH16-100	16	100	63	63
PSC63-BH20-75	20	75	63	50
PSC63-BH20-100	20	100	63	68
PSC63-BH25-75	25	75	63	55
PSC63-BH25-100	25	100	63	68
PSC63-BH32-75	32	75	63	72
PSC63-BH32-100	32	100	63	72
PSC63-BH40-105	40	105	63	70

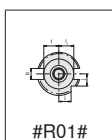

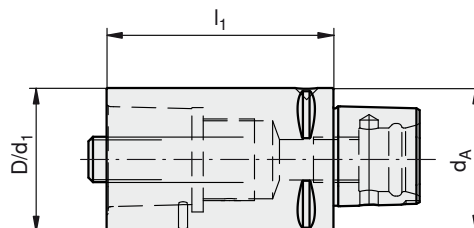
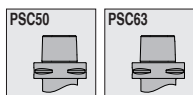

Type, description	d ₁ [mm]	l ₁ [mm]	d _A [mm]	D [mm]	Torque moment [Nm]	
PSC50-V80	50	80	50	50	--	E01
PSC50-V100	50	100	50	50	--	E01
PSC63-V100	63	100	63	63	--	E02
PSC63-V140	63	140	63	63	--	E02

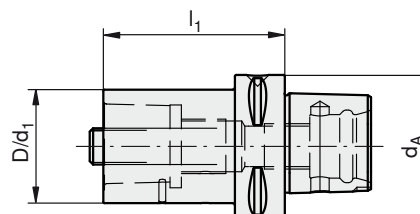

Type, description	d ₁ [mm]	l ₁ [mm]	d _A [mm]	D [mm]	Torque moment [Nm]	
PSC63-R50-80	50	80	63	50	--	E02

E01	12087020	12087022
E02	12087021	12087023

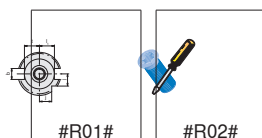

PSC

Blanks / Test bars

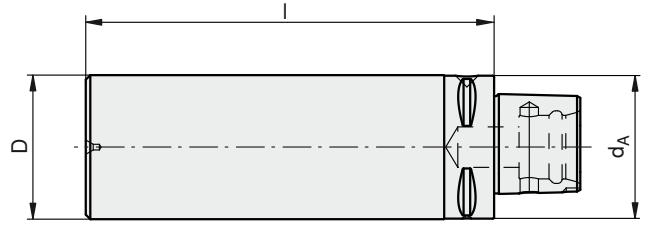
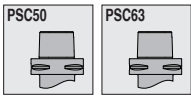

Type, description	d_A [mm]	D [mm]	l [mm]
PSC50-HF50-125	50	50	125
PSC50-HF50-150	50	50	150
PSC63-HF63-180	63	63	180
PSC50-HF75-175	50	75	175
PSC63-HF75-195	63	75	195
PSC50-HF90-80	50	90	80
PSC50-HF95-150	50	95	150
PSC50-HF110-90	50	110	90
PSC63-HF110-85	63	110	85
PSC63-HF120-180	63	120	180
PSC63-HF130-95	63	130	95

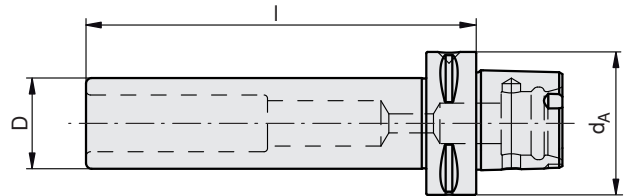
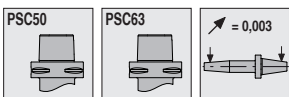

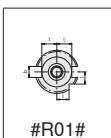

Type, description	d_A [mm]	D [mm]	l [mm]
PSC50-KD32-235	50	32	235
PSC63-KD40-322	63	40	322

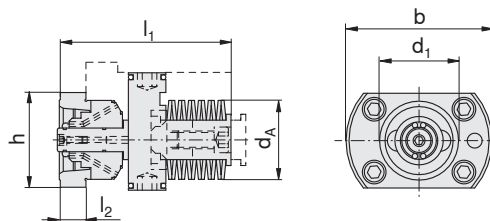

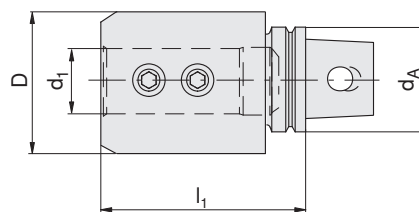

Type, description	d ₁ [mm]	d _A [mm]	l ₂ [mm]	l ₁ [mm]	h [mm]	b [mm]
UT40-ES1473-OSN	40	40	14	87.5	46	74
UT40-ES1473-SSN	40	40	14	87.5	46	74



Type, description	d ₁ [mm]	l ₁ [mm]	d _A [mm]	D [mm]	
UT63-BH40-75-MIY	40	75	63	75	E01



E01



225430

UTS

Single shank holders / Multiple tool holders

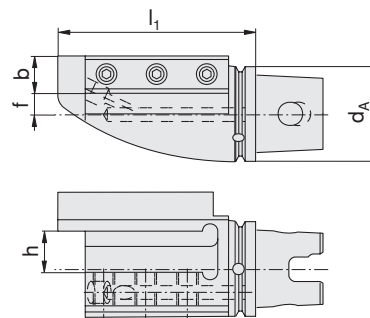

Type, description	d _A [mm]	l ₁ [mm]	f [mm]	b [mm]	h [mm]	
UT63-SHR2525-MIY	63	130	13	25	25	E01
UT63-SHL2525-MIY	63	130	13	25	25	E01

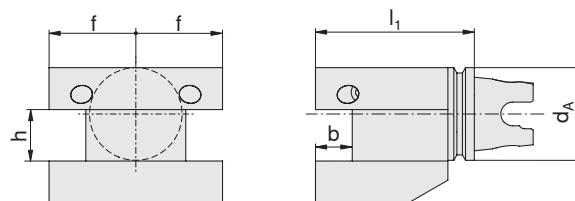

Type, description	d _A [mm]	l ₁ [mm]	f [mm]	b [mm]	h [mm]	
UT63-SH4-2020-MIY	63	110	27.8	20	20	E02
UT63-3225-KN	63	108	34	25	32	E03

E01	231176	11106932	225430
E02			225430
E03	231176		225430

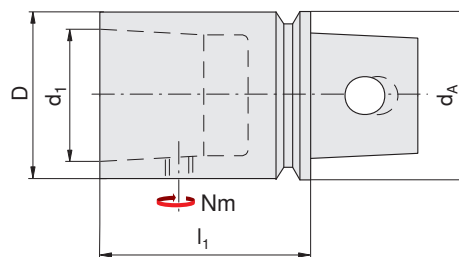
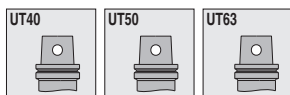

Type, description	d_A [mm]	d_1 [mm]	D [mm]	l_1 [mm]	Torque moment [Nm]	
UT40-AD-VLG 60	40	40	40	60	16	E01
UT40-AD-VLG 80	40	40	40	80	16	E01
UT50-AD-VLG 140	50	50	50	140	32	E02
UT63-V63-80-MIY	63	63	63	80	50	E03
UT63-AD-VLG 100	63	63	63	100	50	E03
UT63-V63-120-MIY	63	63	63	120	50	E03
UT63-AD-VLG 140	63	63	63	140	50	E03

E01	194263	
E02	225429	
E03	225430	

UTS

Blanks / Test bars

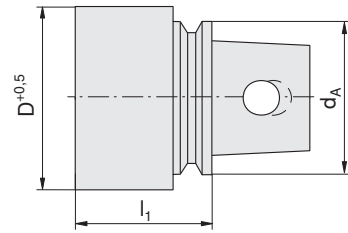
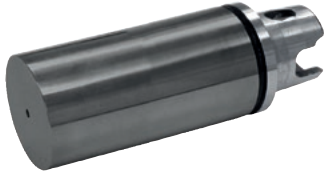
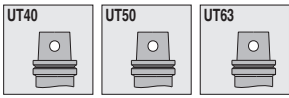

Type, description	d _A [mm]	D [mm]	l [mm]
UT40-HF49-60	40	49	60
UT40-HF49-112	40	49	112
UT40-HF49-120	40	49	120
UT40-HF72-49	40	72	49
UT40-HF72-130	40	72	130
UT40-HF88-80	40	88	80
UT40-HF88-150	40	88	150
UT50-HF55-200	50	55	200
UT50-HF105-100	50	105	100
UT63-HF63-112	63	63	112
UT63-HF74-250	63	74	250
UT63-HF88-75	63	88	75
UT63-HF88-141-MIY	63	88	141
UT63-HF115-150	63	115	150
UT63-HF125-120	63	125	120

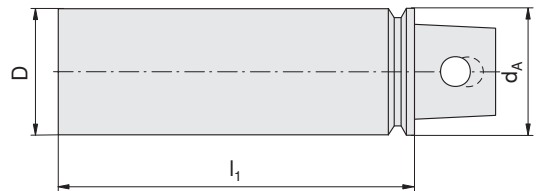
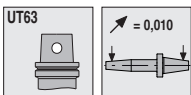

Type, description	d _A [mm]	D [mm]	l [mm]
UT63-AD-AD	63	63	120

Collets ER16/426E / collets ER20/428E

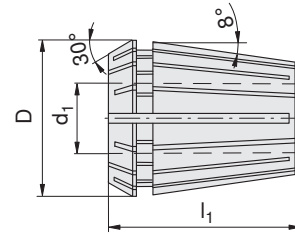

Type, description	d ₁ [mm]	d _{1 min} [mm]	d _{1 max} [mm]	D [mm]	l ₁ [mm]
DIN6499-B-426E/ER16.SZ.Ø1,0	1.0	0.50	1.00	17.25	27.5
DIN6499-B-426E/ER16.SZ.Ø2,0	2.0	1.50	2.00	17.25	27.5
DIN6499-B-426E/ER16.SZ.Ø3,0	3.0	2.50	3.00	17.25	27.5
DIN6499-B-426E/ER16.SZ.Ø4,0	4.0	3.00	4.00	17.25	27.5
DIN6499-B-426E/ER16.SZ.Ø5,0	5.0	4.00	5.00	17.25	27.5
DIN6499-B-426E/ER16.SZ.Ø6,0	6.0	5.00	6.00	17.25	27.5
DIN6499-B-426E/ER16.SZ.Ø7,0	7.0	6.00	7.00	17.25	27.5
DIN6499-B-426E/ER16.SZ.Ø8,0	8.0	7.00	8.00	17.25	27.5
DIN6499-B-426E/ER16.SZ.Ø9,0	9.0	8.00	9.00	17.25	27.5
DIN6499-B-426E/ER16.SZ.Ø10,0	10.0	9.00	10.00	17.25	27.5
DIN6499-B-426E/ER16.SZ				17.25	27.5

Set in wooden box: DIN6499-B-426E/ER16.SZ

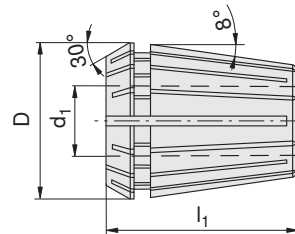

Type, description	d ₁ [mm]	d _{1 min} [mm]	d _{1 max} [mm]	D [mm]	l ₁ [mm]
428E-010	1.0	0.50	1.00	21.3	31.5
428E-020	2.0	1.50	2.00	21.3	31.5
428E-030	3.0	2.50	3.00	21.3	31.5
428E-040	4.0	3.00	4.00	21.3	31.5
428E-050	5.0	4.00	5.00	21.3	31.5
428E-060	6.0	5.00	6.00	21.3	31.5
428E-070	7.0	6.00	7.00	21.3	31.5
428E-080	8.0	7.00	8.00	21.3	31.5
428E-090	9.0	8.00	9.00	21.3	31.5
428E-100	10.0	9.00	10.00	21.3	31.5
428E-110	11.0	10.00	11.00	21.3	31.5
428E-120	12.0	11.00	12.00	21.3	31.5
428E-130	13.0	12.00	13.00	21.3	31.5
428E-SET				21.3	31.5

Set in wooden box: 428E-SET

Collets ER25/430E / collets ER32/470E

G88

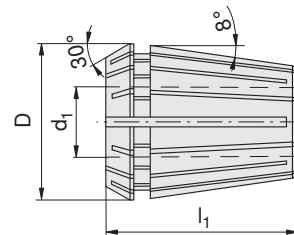

Type, description	d ₁ [mm]	d _{1 min} [mm]	d _{1 max} [mm]	D [mm]	l ₁ [mm]
430E-020	2.0	1.50	2.00	26.3	34
430E-030	3.0	2.50	3.00	26.3	34
430E-040	4.0	3.00	4.00	26.3	34
430E-050	5.0	4.00	5.00	26.3	34
430E-060	6.0	5.00	6.00	26.3	34
430E-070	7.0	6.00	7.00	26.3	34
430E-080	8.0	7.00	8.00	26.3	34
430E-090	9.0	8.00	9.00	26.3	34
430E-100	10.0	9.00	10.00	26.3	34
430E-110	11.0	10.00	11.00	26.3	34
430E-120	12.0	11.00	12.00	26.3	34
430E-130	13.0	12.00	13.00	26.3	34
430E-140	14.0	13.00	14.00	26.3	34
430E-150	15.0	14.00	15.00	26.3	34
430E-160	16.0	15.00	16.00	26.3	34
430E-SET				26.3	34

Set in wooden box: 430E-SET

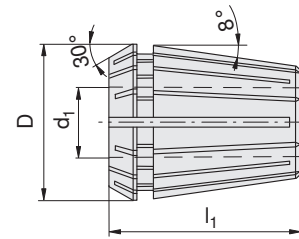

Type, description	d ₁ [mm]	d _{1 min} [mm]	d _{1 max} [mm]	D [mm]	l ₁ [mm]
470E-030	3.0	2.50	3.00	33.35	40
470E-040	4.0	3.00	4.00	33.35	40
470E-050	5.0	4.00	5.00	33.35	40
470E-060	6.0	5.00	6.00	33.35	40
470E-070	7.0	6.00	7.00	33.35	40
470E-080	8.0	7.00	8.00	33.35	40
470E-090	9.0	8.00	9.00	33.35	40
470E-100	10.0	9.00	10.00	33.35	40
470E-110	11.0	10.00	11.00	33.35	40
470E-120	12.0	11.00	12.00	33.35	40
470E-130	13.0	12.00	13.00	33.35	40
470E-140	14.0	13.00	14.00	33.35	40
470E-150	15.0	14.00	15.00	33.35	40
470E-160	16.0	15.00	16.00	33.35	40
470E-170	17.0	16.00	17.00	33.35	40
470E-180	18.0	17.00	18.00	33.35	40
470E-190	19.0	18.00	19.00	33.35	40
470E-200	20.0	19.00	20.00	33.35	40
470E-SET				33.35	40

Set in wooden box: 470E-SET

Collets ER40/472E

G90

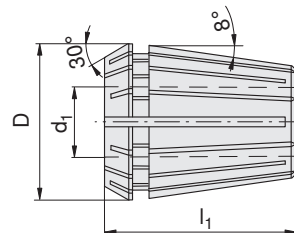

Type, description	d ₁ [mm]	d _{1 min} [mm]	d _{1 max} [mm]	D [mm]	l ₁ [mm]
472E-030	3.0	2.50	3.00	41.4	46
472E-040	4.0	3.00	4.00	41.4	46
472E-050	5.0	4.00	5.00	41.4	46
472E-060	6.0	5.00	6.00	41.4	46
472E-070	7.0	6.00	7.00	41.4	46
472E-080	8.0	7.00	8.00	41.4	46
472E-090	9.0	8.00	9.00	41.4	46
472E-100	10.0	9.00	10.00	41.4	46
472E-110	11.0	10.00	11.00	41.4	46
472E-120	12.0	11.00	12.00	41.4	46
472E-130	13.0	12.00	13.00	41.4	46
472E-140	14.0	13.00	14.00	41.4	46
472E-150	15.0	14.00	15.00	41.4	46
472E-160	16.0	15.00	16.00	41.4	46
472E-170	17.0	16.00	17.00	41.4	46
472E-180	18.0	17.00	18.00	41.4	46
472E-190	19.0	18.00	19.00	41.4	46
472E-200	20.0	19.00	20.00	41.4	46
472E-210	21.0	20.00	21.00	41.4	46
472E-220	22.0	21.00	22.00	41.4	46
472E-230	23.0	22.00	23.00	41.4	46
472E-240	24.0	23.00	24.00	41.4	46
472E-250	25.0	24.00	25.00	41.4	46
472E-260	26.0	25.00	26.00	41.4	46
472E-SET				41.4	46

Set in wooden box: 472E-SET

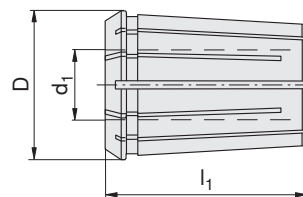

Type, description	d ₁ [mm]	d _{1 min} [mm]	d _{1 max} [mm]	D [mm]	l ₁ [mm]
415E-020	2.0	1.6	2.1	25.5	40
415E-025	2.5	2.1	2.6	25.5	40
415E-030	3.0	2.6	3.1	25.5	40
415E-035	3.5	3.1	3.6	25.5	40
415E-040	4.0	3.6	4.1	25.5	40
415E-045	4.5	4.1	4.6	25.5	40
415E-050	5.0	4.6	5.1	25.5	40
415E-055	5.5	5.1	5.6	25.5	40
415E-060	6.0	5.6	6.1	25.5	40
415E-065	6.5	6.1	6.6	25.5	40
415E-070	7.0	6.6	7.1	25.5	40
415E-075	7.5	7.1	7.6	25.5	40
415E-080	8.0	7.6	8.1	25.5	40
415E-085	8.5	8.1	8.6	25.5	40
415E-090	9.0	8.6	9.1	25.5	40
415E-095	9.5	9.1	9.6	25.5	40
415E-100	10.0	9.6	10.1	25.5	40
415E-105	10.5	10.1	10.6	25.5	40
415E-110	11.0	10.6	11.1	25.5	40
415E-115	11.5	11.1	11.6	25.5	40
415E-120	12.0	11.6	12.1	25.5	40
415E-125	12.5	12.1	12.6	25.5	40
415E-130	13.0	12.6	13.1	25.5	40
415E-135	13.5	13.1	13.6	25.5	40
415E-140	14.0	13.6	14.1	25.5	40
415E-145	14.5	14.1	14.6	25.5	40
415E-150	15.0	14.6	15.1	25.5	40
415E-155	15.5	15.1	15.6	25.5	40
415E-160	16.0	15.6	16.1	25.5	40

Collets 462E

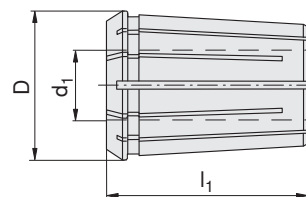

Type, description	d ₁ [mm]	d _{1 min} [mm]	d _{1 max} [mm]	D [mm]	l ₁ [mm]
462E-020	2.0	1.6	2.1	35.05	52
462E-025	2.5	2.1	2.6	35.05	52
462E-030	3.0	2.6	3.1	35.05	52
462E-035	3.5	3.1	3.6	35.05	52
462E-040	4.0	3.6	4.1	35.05	52
462E-045	4.5	4.1	4.6	35.05	52
462E-050	5.0	4.6	5.1	35.05	52
462E-055	5.5	5.1	5.6	35.05	52
462E-060	6.0	5.6	6.1	35.05	52
462E-065	6.5	6.1	6.6	35.05	52
462E-070	7.0	6.6	7.1	35.05	52
462E-075	7.5	7.1	7.6	35.05	52
462E-080	8.0	7.6	8.1	35.05	52
462E-085	8.5	8.1	8.6	35.05	52
462E-090	9.0	8.6	9.1	35.05	52
462E-095	9.5	9.1	9.6	35.05	52
462E-100	10.0	9.6	10.1	35.05	52
462E-105	10.5	10.1	10.6	35.05	52
462E-110	11.0	10.6	11.1	35.05	52
462E-115	11.5	11.1	11.6	35.05	52
462E-120	12.0	11.6	12.1	35.05	52
462E-125	12.5	12.1	12.6	35.05	52
462E-130	13.0	12.6	13.1	35.05	52
462E-135	13.5	13.1	13.6	35.05	52
462E-140	14.0	13.6	14.1	35.05	52
462E-145	14.5	14.1	14.6	35.05	52
462E-150	15.0	14.6	15.1	35.05	52
462E-155	15.5	15.1	15.6	35.05	52
462E-160	16.0	15.6	16.1	35.05	52
462E-165	16.5	16.1	16.6	35.05	52
462E-170	17.0	16.6	17.1	35.05	52
462E-175	17.5	17.1	17.6	35.05	52
462E-180	18.0	17.6	18.1	35.05	52
462E-185	18.5	18.1	18.6	35.05	52
462E-190	19.0	18.6	19.1	35.05	52
462E-195	19.5	19.1	19.6	35.05	52
462E-200	20.0	19.6	20.1	35.05	52
462E-205	20.5	20.1	20.6	35.05	52
462E-210	21.0	20.6	21.1	35.05	52
462E-215	21.5	21.1	21.6	35.05	52
462E-220	22.0	21.6	22.1	35.05	52
462E-225	22.5	22.1	22.6	35.05	52
462E-230	23.0	22.6	23.1	35.05	52
462E-235	23.5	23.1	23.6	35.05	52
462E-240	24.0	23.6	24.1	35.05	52
462E-245	24.5	24.1	24.6	35.05	52
462E-250	25.0	24.6	25.1	35.05	52

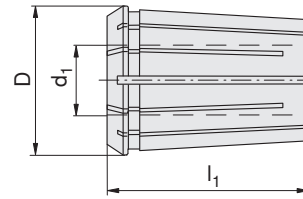

Type, description	d ₁ [mm]	d _{1 min} [mm]	d _{1 max} [mm]	D [mm]	l ₁ [mm]
467E-040	4.0	3.6	4.1	43.7	60
467E-045	4.5	4.1	4.6	43.7	60
467E-050	5.0	4.6	5.1	43.7	60
467E-055	5.5	5.1	5.6	43.7	60
467E-060	6.0	5.6	6.1	43.7	60
467E-065	6.5	6.1	6.6	43.7	60
467E-070	7.0	6.6	7.1	43.7	60
467E-075	7.5	7.1	7.6	43.7	60
467E-080	8.0	7.6	8.1	43.7	60
467E-085	8.5	8.1	8.6	43.7	60
467E-090	9.0	8.6	9.1	43.7	60
467E-095	9.5	9.1	9.6	43.7	60
467E-100	10.0	9.6	10.1	43.7	60
467E-105	10.5	10.1	10.6	43.7	60
467E-110	11.0	10.6	11.1	43.7	60
467E-115	11.5	11.1	11.6	43.7	60
467E-120	12.0	11.6	12.1	43.7	60
467E-125	12.5	12.1	12.6	43.7	60
467E-130	13.0	12.6	13.1	43.7	60
467E-135	13.5	13.1	13.6	43.7	60
467E-140	14.0	13.6	14.1	43.7	60
467E-145	14.5	14.1	14.6	43.7	60
467E-150	15.0	14.6	15.1	43.7	60
467E-155	15.5	15.1	15.6	43.7	60
467E-160	16.0	15.6	16.1	43.7	60
467E-165	16.5	16.1	16.6	43.7	60
467E-170	17.0	16.6	17.1	43.7	60
467E-175	17.5	17.1	17.6	43.7	60
467E-180	18.0	17.6	18.1	43.7	60
467E-185	18.5	18.1	18.6	43.7	60
467E-190	19.0	18.6	19.1	43.7	60
467E-195	19.5	19.1	19.6	43.7	60

Collets 467E

G94

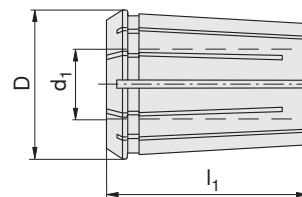

Type, description	d ₁ [mm]	d _{1 min} [mm]	d _{1 max} [mm]	D [mm]	l ₁ [mm]
467E-200	20.0	19.6	20.1	43.7	60
467E-205	20.5	20.1	20.6	43.7	60
467E-210	21.0	20.6	21.1	43.7	60
467E-215	21.5	21.1	21.6	43.7	60
467E-220	22.0	21.6	22.1	43.7	60
467E-225	22.5	22.1	22.6	43.7	60
467E-230	23.0	22.6	23.1	43.7	60
467E-235	23.5	23.1	23.6	43.7	60
467E-240	24.0	23.6	24.1	43.7	60
467E-245	24.5	24.1	24.6	43.7	60
467E-250	25.0	24.6	25.1	43.7	60
467E-255	25.5	25.1	25.6	43.7	60
467E-260	26.0	25.6	26.1	43.7	60
467E-265	26.5	26.1	26.6	43.7	60
467E-270	27.0	26.6	27.1	43.7	60
467E-275	27.5	27.1	27.6	43.7	60
467E-280	28.0	27.6	28.1	43.7	60
467E-285	28.5	28.1	28.6	43.7	60
467E-290	29.0	28.6	29.1	43.7	60
467E-295	29.5	29.1	29.6	43.7	60
467E-300	30.0	29.6	30.1	43.7	60
467E-305	30.5	30.1	30.6	43.7	60
467E-310	31.0	30.6	31.1	43.7	60
467E-315	31.5	31.1	31.6	43.7	60
467E-320	32.0	31.6	32.1	43.7	60

Lock nuts ER / lock nuts ER-D

G95

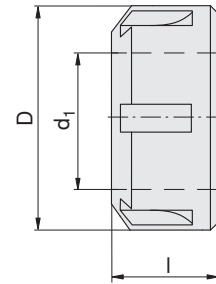

Type, description	l [mm]	D [mm]	d ₁ [mm]
SM-ER16/M22x1,5	17.0	32	M22x1,5
SM-ER20/M25x1,5	19.5	34	M25x1,5
SM-ER25/M32X1,5	20.0	42	M32x1,5
SM-ER32/M40x1,5	22.3	50	M40x1,5
SM-ER40/M50x1,5	25.3	63	M50x1,5

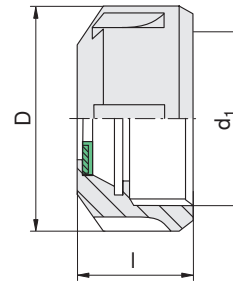

Type, description	l [mm]	D [mm]	d ₁ [mm]
SM-ER16D	22.0	32	M22x1,5
SM-ER25D	24.7	42	M32x1,5
SM-ER32D	27.0	50	M40x1,5
SM-ER40D	30.7	63	M50x1,5

Lock nuts OZ

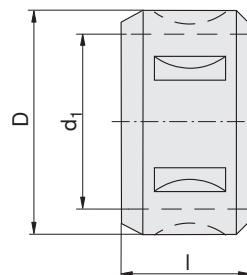

Type, description	l [mm]	D [mm]	d ₁ [mm]
SM-BC2-16	24.0	43	M33x1,5
SM-BC2-25	30.0	60	M48x2,0

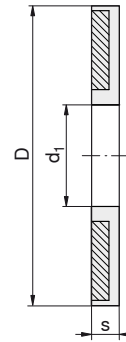

Type, description	d ₁ [mm]	D [mm]	s [mm]
DS-426E-020	2.0	12.6	2.0
DS-426E-025	2.5	12.6	2.0
DS-426E-030	3.0	12.6	2.0
DS-426E-035	3.5	12.6	2.0
DS-426E-040	4.0	12.6	2.0
DS-426E-045	4.5	12.6	2.0
DS-426E-050	5.0	12.6	2.0
DS-426E-055	5.5	12.6	2.0
DS-426E-060	6.0	12.6	2.0
DS-426E-065	6.5	12.6	2.0
DS-426E-070	7.0	12.6	2.0
DS-426E-075	7.5	12.6	2.0
DS-426E-080	8.0	12.6	2.0
DS-426E-085	8.5	12.6	2.0
DS-426E-090	9.0	12.6	2.0
DS-426E-095	9.5	12.6	2.0
DS-426E-100	10.0	12.6	2.0
DS-430E-020	2.0	20.2	2.0
DS-430E-025	2.5	20.2	2.0
DS-430E-030	3.0	20.2	2.0
DS-430E-035	3.5	20.2	2.0
DS-430E-040	4.0	20.2	2.0
DS-430E-045	4.5	20.2	2.0
DS-430E-050	5.0	20.2	2.0
DS-430E-055	5.5	20.2	2.0
DS-430E-060	6.0	20.2	2.0
DS-430E-065	6.5	20.2	2.0
DS-430E-070	7.0	20.2	2.0
DS-430E-075	7.5	20.2	2.0
DS-430E-080	8.0	20.2	2.0
DS-430E-085	8.5	20.2	2.0
DS-430E-090	9.0	20.2	2.0
DS-430E-095	9.5	20.2	2.0
DS-430E-100	10.0	20.2	2.0
DS-430E-105	10.5	20.2	2.0
DS-430E-110	11.0	20.2	2.0
DS-430E-115	11.5	20.2	2.0
DS-430E-120	12.0	20.2	2.0
DS-430E-125	12.5	20.2	2.0
DS-430E-130	13.0	20.2	2.0
DS-430E-135	13.5	20.2	2.0
DS-430E-140	14.0	20.2	2.0
DS-430E-145	14.5	20.2	2.0
DS-430E-150	15.0	20.2	2.0
DS-430E-155	15.5	20.2	2.0
DS-430E-160	16.0	20.2	2.0

Sealing rings

G98

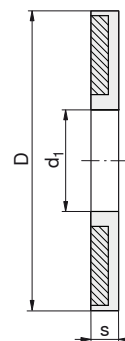

Type, description	d ₁ [mm]	D [mm]	s [mm]
DS-470E-020	2.0	26.2	2.0
DS-470E-025	2.5	26.2	2.0
DS-470E-030	3.0	26.2	2.0
DS-470E-035	3.5	26.2	2.0
DS-470E-040	4.0	26.2	2.0
DS-470E-045	4.5	26.2	2.0
DS-470E-050	5.0	26.2	2.0
DS-470E-055	5.5	26.2	2.0
DS-470E-060	6.0	26.2	2.0
DS-470E-065	6.5	26.2	2.0
DS-470E-070	7.0	26.2	2.0
DS-470E-075	7.5	26.2	2.0
DS-470E-080	8.0	26.2	2.0
DS-470E-085	8.5	26.2	2.0
DS-470E-090	9.0	26.2	2.0
DS-470E-095	9.5	26.2	2.0
DS-470E-100	10.0	26.2	2.0
DS-470E-105	10.5	26.2	2.0
DS-470E-110	11.0	26.2	2.0
DS-470E-115	11.5	26.2	2.0
DS-470E-120	12.0	26.2	2.0
DS-470E-125	12.5	26.2	2.0
DS-470E-130	13.0	26.2	2.0
DS-470E-135	13.5	26.2	2.0
DS-470E-140	14.0	26.2	2.0
DS-470E-145	14.5	26.2	2.0
DS-470E-150	15.0	26.2	2.0
DS-470E-155	15.5	26.2	2.0
DS-470E-160	16.0	26.2	2.0
DS-470E-165	16.5	26.2	2.0
DS-470E-170	17.0	26.2	2.0
DS-470E-175	17.5	26.2	2.0
DS-470E-180	18.0	26.2	2.0
DS-470E-185	18.5	26.2	2.0
DS-470E-190	19.0	26.2	2.0
DS-470E-195	19.5	26.2	2.0
DS-470E-200	20.0	26.2	2.0

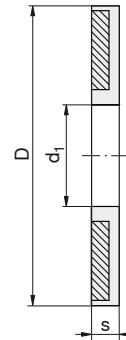

Type, description	d ₁ [mm]	D [mm]	s [mm]
DS-472E-030	3.0	34.2	2.0
DS-472E-035	3.5	34.2	2.0
DS-472E-040	4.0	34.2	2.0
DS-472E-045	4.5	34.2	2.0
DS-472E-050	5.0	34.2	2.0
DS-472E-055	5.5	34.2	2.0
DS-472E-060	6.0	34.2	2.0
DS-472E-065	6.5	34.2	2.0
DS-472E-070	7.0	34.2	2.0
DS-472E-075	7.5	34.2	2.0
DS-472E-080	8.0	34.2	2.0
DS-472E-085	8.5	34.2	2.0
DS-472E-090	9.0	34.2	2.0
DS-472E-095	9.5	34.2	2.0
DS-472E-100	10.0	34.2	2.0
DS-472E-105	10.5	34.2	2.0
DS-472E-110	11.0	34.2	2.0
DS-472E-115	11.5	34.2	2.0
DS-472E-120	12.0	34.2	2.0
DS-472E-125	12.5	34.2	2.0
DS-472E-130	13.0	34.2	2.0
DS-472E-135	13.5	34.2	2.0
DS-472E-140	14.0	34.2	2.0
DS-472E-145	14.5	34.2	2.0
DS-472E-150	15.0	34.2	2.0
DS-472E-155	15.5	34.2	2.0
DS-472E-160	16.0	34.2	2.0
DS-472E-165	16.5	34.2	2.0
DS-472E-170	17.0	34.2	2.0
DS-472E-175	17.5	34.2	2.0
DS-472E-180	18.0	34.2	2.0
DS-472E-185	18.5	34.2	2.0
DS-472E-190	19.0	34.2	2.0
DS-472E-195	19.5	34.2	2.0
DS-472E-200	20.0	34.2	2.0
DS-472E-205	20.5	34.2	2.0
DS-472E-210	21.0	34.2	2.0
DS-472E-215	21.5	34.2	2.0
DS-472E-220	22.0	34.2	2.0
DS-472E-225	22.5	34.2	2.0
DS-472E-230	23.0	34.2	2.0
DS-472E-235	23.5	34.2	2.0
DS-472E-240	24.0	34.2	2.0
DS-472E-245	24.5	34.2	2.0
DS-472E-250	25.0	34.2	2.0
DS-472E-255	25.5	34.2	2.0
DS-472E-260	26.0	34.2	2.0

Pull studs SK / pull studs MAS-BT

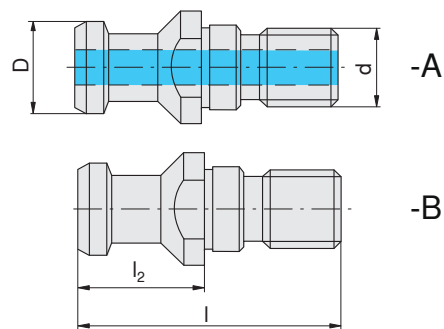

Type, description	SK	D [mm]	l ₂ [mm]	l [mm]	Thread size
69872-A19	40	23	26	54	M16
69872-A28	50	36	34	74	M24
69872-B19	40	23	26	54	M16
69872-B28	50	36	34	74	M24

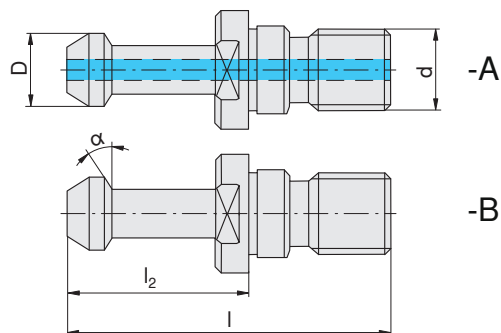

Type, description	MAS-BT	α [°]	D [mm]	l ₂ [mm]	l [mm]	Thread size
MAS-BT-30-A15	40	30	23	35	60	M16
MAS-BT-30-A23	50	30	38	45	85	M24
MAS-BT-30-B15	40	30	23	35	60	M16
MAS-BT-30-B23	50	30	38	45	85	M24
MAS-BT-45-A15	40	45	23	35	60	M16
MAS-BT-45-A23	50	45	38	45	85	M24
MAS-BT-45-B15	40	45	23	35	60	M16
MAS-BT-45-B23	50	45	38	45	85	M24
MAS-BT-90-A15	40	90	23	35	60	M16
MAS-BT-90-A23	50	90	38	45	85	M24
MAS-BT-90-B15	40	90	23	35	60	M16
MAS-BT-90-B23	50	90	38	45	85	M24

Pulls studs DIN 7388 / reducers MK

G101

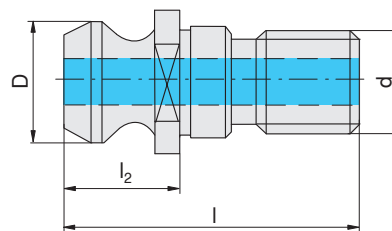

Type, description	SK	D [mm]	l_2 [mm]	l [mm]	Thread size
ISO/DIS7388-40.M16	40	22.5	16.40	41.26	M16
ISO/DIS7388-50.M24	50	37.0	25.55	65.50	M24

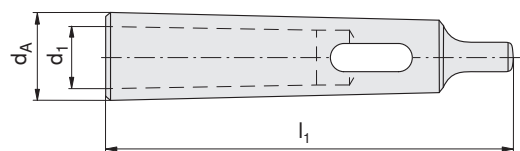

Type, description	d_A Morse taper [MK]	d_1 Morse taper [MK]	l_1 [mm]
DIN2185.MK1-MK0-80	MK1	MK0	80
DIN2185.MK2-MK1-92	MK2	MK1	92
DIN2185.MK3-MK1-99	MK3	MK1	99
DIN2185.MK3-MK2-112	MK3	MK2	112
DIN2185.MK4-MK1-124	MK4	MK1	124
DIN2185.MK4-MK2-124	MK4	MK2	124
DIN2185.MK4-MK3-140	MK4	MK3	140
DIN2185.MK5-MK3-156	MK5	MK3	156
DIN2185.MK5-MK2-156	MK5	MK2	156
DIN2185.MK5-MK4-171	MK5	MK4	171

Reducers for hydraulic expansion chucks

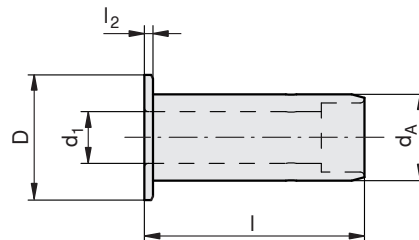
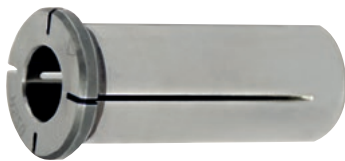

Type, description	d ₁ [mm]	d _A [mm]	l [mm]	D [mm]	l ₂ [mm]
HD12-R03	3	12	44.5	19	2
HD12-R04	4	12	44.5	19	2
HD12-R05	5	12	44.5	19	2
HD12-R06	6	12	44.5	19	2
HD12-R08	8	12	44.5	19	2
HD20-R03	3	20	51	29	2
HD20-R04	4	20	51	29	2
HD20-R05	5	20	51	29	2
HD20-R06	6	20	51	29	2
HD20-R07	7	20	51	29	2
HD20-R08	8	20	51	29	2
HD20-R09	9	20	51	29	2
HD20-R10	10	20	51	29	2
HD20-R11	11	20	51	29	2
HD20-R12	12	20	51	29	2
HD20-R13	13	20	51	29	2
HD20-R14	14	20	51	29	2
HD20-R15	15	20	51	29	2
HD20-R16	16	20	51	29	2
HD32-R06	6	32	64	40	3
HD32-R08	8	32	64	40	3
HD32-R10	10	32	64	40	3
HD32-R12	12	32	64	40	3
HD32-R14	14	32	64	40	3
HD32-R16	16	32	64	40	3
HD32-R18	18	32	64	40	3
HD32-R20	20	32	64	40	3
HD32-R25	25	32	64	40	3

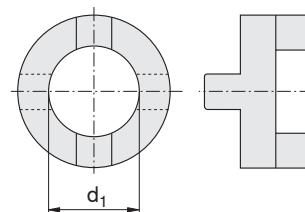
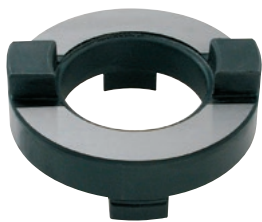

Type, description	d_1 [mm]
83370116/ Ø16/DIN 6366	16
83370122/ Ø22/DIN 6366	22
83370127/ Ø27/DIN 6366	27
83370132/ Ø32/DIN 6366	32
83370140/ Ø40/DIN 6366	40
83370150/ Ø50/DIN 6366	50

Technical data of ISO adapters (SK, HSK)

DIN 69871 form A

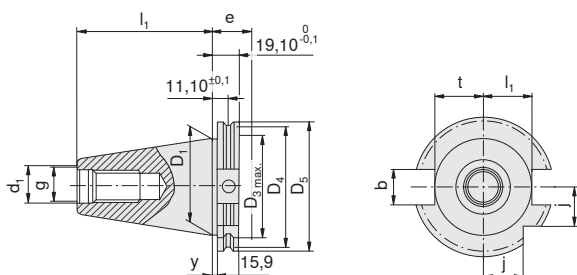

DIN 69871 form B

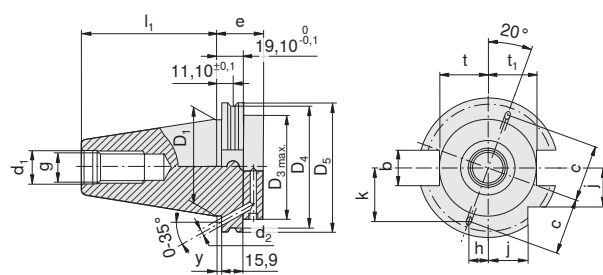

	D ₁	D _{3 max}	D ₄	D ₅	l ₁ ^{+0,2}	g	d ₁ ^{H7}	e	y ^{+0,1}	t	t ₁	j	d ₂	h	k	c	b
	[mm]	[mm]	[mm]	[mm]	[mm]		[mm]	[mm]	[mm]	[mm]	[mm]	[mm]	[mm]	[mm]	[mm]	[mm]	[mm]
SK 40	44,45	50	56,25	63,55	68,4	M 16	17	35	3,2	22,8	25	18,5	4	9,2	25,4	27	16,1
SK 50	69,85	80	91,25	97,5	101,75	M 24	25	35	3,2	35,5	37,7	30	6	14,4	39,5	42	25,7

MAS-BT

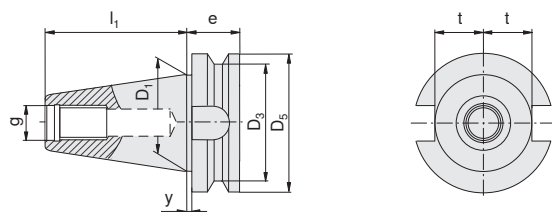

	D ₁	D ₃	D ₅	l ₁	g	e	t	y	b
	[mm]	[mm]	[mm]	[mm]		[mm]	[mm]	[mm]	[mm]
BT 40	44,45	53	63	65,4	M 16	27	22,5	2	16,1
BT 50	69,85	85	100	101,8	M 24	38	35,3	3,2	25,7

HSK DIN 69893 A+C

Recommended parameters for HSK-A adapters

HSK-A 63 up to 25,000 min⁻¹
 HSK-A 100 up to 16,000 min⁻¹

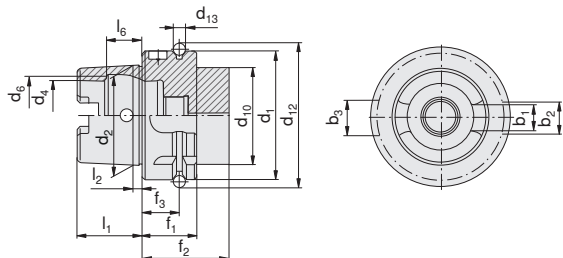

	b ₁	b ₂	b ₃	d ₁	d ₂	d ₄	d ₆	d ₁₀	d ₁₂	f ₁	f ₂	b ₁	f ₃	l ₁	l ₂	l ₆
	[mm]	[mm]	[mm]	[mm]	[mm]	[mm]	[mm]	[mm]	[mm]	[mm]	[mm]	[mm]	[mm]	[mm]	[mm]	[mm]
HSK 63	12,54	16	18	63	48	34	37	53	72,3	7	26	42	18	32	6,3	18,13
HSK 100	20,02	20	22	100	75	53	58	88	109,75	7	29	45	20	50	10	28,56

Technical data for PSC / hydraulic expansion chucks

PSC

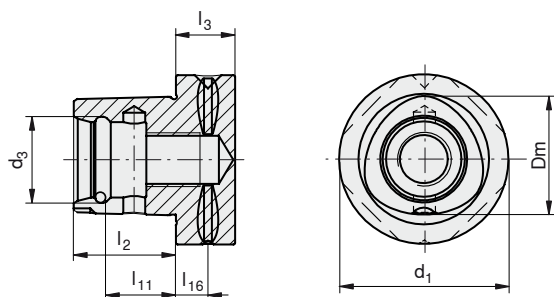

	d_1 [mm]	d_3 [mm]	l_2 [mm]	l_3 [mm]	l_{11} [mm]	l_{16} [mm]	D_m [mm]
PSC 50	50	24	30	20	22	12	35
PSC 63	63	32	38	22	26	12	44

Hydraulic expansion chuck

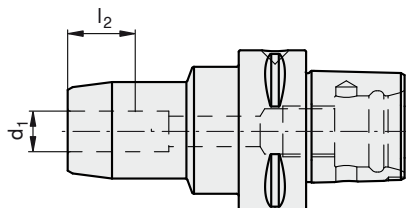





d_1 h6 [mm]	Max. rev number [min ⁻¹]	Max. torque moment [Nm]	Min. clamping depth l_2 [mm]	Max. adjustment [mm]	Optimal operating temperature [°C]	Max. coolant pressure [bar]
6	40 000	20	28	10	20 - 50	80
8	40 000	30	28	10	20 - 50	80
10	40 000	50	33	10	20 - 50	80
12	40 000	85	28	10	20 - 50	80
14	40 000	110	38	10	20 - 50	80
16	40 000	180	41	10	20 - 50	80
18	40 000	240	41	10	20 - 50	80
20	40 000	310	43	10	20 - 50	80
25	40 000	420	49	10	20 - 50	80
32	40 000	650	53	10	20 - 50	80

Spare parts



	Material	Type, description
	8337011600	83370116/ Ø16/DIN 6366
	8337012200	83370122/ Ø22/DIN 6366
	8337012700	83370127/ Ø27/DIN 6366
	8337013200	83370132/ Ø32/DIN 6366
	8337014000	83370140/ Ø40/DIN 6366
	8337015000	83370150/ Ø50/DIN 6366
	12087073	MS-KA16
	12087074	MS-KA22
	12087075	MS-KA27
	12087076	MS-KA32
	12087077	MS-KA40
	8395012000	8X9X17,5
	8395012100	10X11X20,5
	8395012200	12X13X24,3
	8395012300	14X21X21,2
	8395029500	15,9X16,3X19,5
	8395029800	25,4X25X26,5
	12087068	4x4x14 DIN 6885 FORM A
	12087069	6x6x16 DIN 6885 FORM A
	12087070	7x7x18 DIN 6885 FORM A
	12087071	8x7x20 DIN 6885 FORM A
	12087072	10x8x22 DIN 6885 FORM A
	8395028400	82998015.4X4X20
	8395028500	82998016.6X6X25
	8395028600	82998017.7X7X25
	8395028700	82998018.8X7X28
	8395028800	82998019.10X8X32
8395028900	82998020.12X8X36	
	6295005000	SM-BC2-16
	6295005100	SM-BC2-25
	8395005500	SM-ER25D
	8395005600	SM-ER32D
	8395005700	SM-ER40D
	6295004500	SM-ER20/M25x1,5
	6295005400	SM-ER16/M22x1,5
	6295005500	SM-ER25/M32x1,5
	6295005600	SM-ER32/M40x1,5
	6295005700	SM-ER40/M50x1,5
	8336811600	604016.Ø16
	8336812200	604022.Ø22
	8336812700	604027.Ø27
	8336813200	604032.Ø32
	8336814000	83 368 140
	12001280	10014334/S-D12-D1.3
	8335901300	SCHL.13X62
	8335901700	SCHL.17X117
	8335902000	SCHL.20X135
	8335902300	SCHL.23X145
	8335903300	SCHL.33X175
	8335411600	SS-BC2-16
	8335412500	601060.2-25
	8335413200	SS-BC4-32
	8335711600	SS-ER16
	8335712500	SS-ER25
	8335713200	SS-ER32
	8335714000	SS-ER40
	11960178	GS-HSK 10015789-0





	Material	Type, description
	8395026500	83950265/M16x8x6,5/
	8395026600	83950266/M24x10x6,5/
	8395026700	83950267/M16x8x10,5/
	8395026800	83950268/M24x10x10,5/
	8395026900	83950269/M20x1,5x10x13/
	8395027000	83950270/M26x1,5x8x17/
	8395027100	83950271/M36x1,5x8x21/
	8376006300	KMS.HSK63
	8376010000	KMS.HSK100
	194263	7896900/O-RING 40
	225429	7896940/O-RING 50
	225430	7896941/O-RING 63
	11848510	10014329/SD 12X7 100BAR
	231176	7896944/SD 12X8
	12087020	PSC50-SW10
	12087021	PSC63-SW10
	8336701600	604008.M8
	8336702200	604010.M10
	8336702700	604012.M12
	8336703200	604016.M16
	8336704000	83 367 040/M20x30-12,9
	8336705000	83367050/M24/DIN 6367
	12087022	PSC50
	12087023	PSC63
	11210254	10002666/M4X16 DIN912 - 12.9
	8395013600	82998006.M5X12
	8395013700	82998008.M5X20
	8395013800	82998009.M6X16
	8395029600	82998004.M3X8
	8395029700	82998005.M4X12
	12087062	VS-SF-6/7
	12087063	VS-SF-8/9
	12087064	VS-SF-10/11
	12087065	VS-SF-12/14
	12087066	VS-SF-16/18
	12087067	VS-SF-20/25/32

	Material	Type, description	l [mm]	Thread size	Key size
	8395001000	VS-ER25	50	M10	SW5
	8395001100	VS-ER40	50	M12	SW6
	8395003300	83950033/M5x35/DIN 913	35	M5	SW2,5
	8395003400	83950034/M6x35/DIN 913	35	M6	SW3
	8395003500	83950035/M8x35/DIN 913	35	M8	SW4
	8395003600	83950036/M10x35/DIN 913	35	M10	SW5
	8395003700	83950037/M12x40/DIN 913	40	M12	SW7
	8395027200	83950272/M16x45/DIN 913	45	M16	SW8
8395029000	M20x35.SW10	35	M20	SW10	
	11106932	7896982/M12X1.75X25-DIN913	25	M12	SW6
	11154410	VS-ER16-K/M5X8	8	M5	SW2,5
	11154413	VS-ER20-K/M6X12	12	M6	SW3
	11154414	VS-ER25-K/M8X1X14	14	M8	SW4
	11154418	VS-ER32-K/M10X1X14	14	M10	SW5
	11154419	VS-ER40-K/M12X1X18	18	M12	SW6
	6295000600	62 950 006/M6X10	10	M6	SW3
	6295000800	62 950 008/M8x10	10	M8	SW4
	6295001000	62 950 010/M10x12	12	M10	SW5
	6295001200	62 950 012/M12x16	16	M12	SW6
	6295001600	62 950 016/M14x16	16	M14	SW6
	6295002000	62 950 020/M16X16	16	M16	SW8
	6295002500	62 950 025/M18X2X20	20	M18	SW10
	6295003200	62 950 032/M20x2x20	20	M20	SW10
	8395003000	83950030/M5x6/DIN 914	6	M5	SW2,5
	8395003100	83950031/M5x8/DIN 914	8	M5	SW2,5
	333935	7818123/M8X25/DIN912-12.9	25	M8	SW6
	333937	7818124/M10X25/DIN912-12.9	25	M10	SW8
	333940	7818125/M12X30/DIN912-12.9	30	M12	SW10
	333945	7818126/M16X35 DIN912 - 12.9	35	M16	SW14
	8395001700	83950017/M10x30/DIN 7984	30	M10	SW8
	8395001800	83950018/M12x35/DIN7984	35	M12	SW10
	8395001900	83950019/M16x40/DIN7984	40	M16	SW14
	8395011200	M20X40	40	M20	SW17
	8395011300	M8X25	25	M8	SW6
	8395012400	M10X25	25	M10	SW8
	8395012500	M12X30	30	M12	SW10
	8395012600	M16X35	35	M16	SW14
	8395014000	M12X50	50	M12	SW10
	8395016000	M16X45	45	M16	SW14
	8395026000	83950260/1403952/DIN EN ISO 4762	30	M6	SW5
	8395026100	83950261/M10x30/DIN7984	30	M10	SW8
	8395026200	83950262/M20x50/DIN 7984	50	M20	SW17

Index

6		
69871.. BC..	G21	
69871.. ER..	G19	
69871.. HD..	G18	
69871.. HF..	G26	
69871.. KA..	G22	
69871.. KD..	G26	
69871.. MA..	G24	
69871.. MK..	G24	
69871.. MK.. C..	G25	
69871.. QA..	G23	
69871.. SF..	G16, G17	
69871.. WE..	G10, G11, G12, G13, G14	
69871.. WN..	G15	
69871..D.. ER..D..	G20	
69872-A..	G100	
69872-B..	G100	
8		
83 370..	G103	
A		
A491..	B15	
C		
C491..	B16	
CNMG	A11, A12	
D		
DIN2185.. MK..	G101	
DIN6388-B.. 415E..	G91	
DIN6388-B.. 462E..	G92	
DIN6388-B.. 467E..	G93, G94	
DIN6499-B.. 426E..	G87	
DIN6499-B.. 428E..	G87	
DIN6499-B.. 430E..	G88	
DIN6499-B.. 470E..	G89	
DIN6499-B.. 472E..	G90	
DNMG	A11, A12	
DS-426E..	G97	
DS-430E..	G97	
DS-470E..	G98	
DS-472E..	G99	
G		
G491..	B17	
H		
HD12.. R..	G102	
HD20.. R..	G102	
HD32.. R..	G102	
HSK A.. D0..	G51	
HSK A.. D1..	G51	
HSK A.. D2..	G51	
HSK A.. D3..	G51	
HSK A.. ER..	G52	
HSK A.. F4..	G48, G49	
HSK A.. HD..	G51	
HSK A.. HF..	G57	
HSK A.. KD..	G57, G76	
HSK A.. M..	G54	
HSK A.. MK..	G55	
HSK A.. QA..	G53	
HSK A.. SF..	G49, G50	
HSK A.. WE..	G44, G45	
HSK A.. WN..	G46, G47	
HSK T.. BH..	G74	
HSK T.. HF..	G76	
HSK T.. PS..	G56	
HSK T.. R..	G75	
HSK T.. SC..	G56	
HSK T.. SH3..	G73	
HSK T.. SHL00..	G72	
HSK T.. SHL45..	G72	
HSK T.. SHN90..	G73	
HSK T.. SHR00..	G72	
HSK T.. SHR45..	G72	
HSK T.. UT..	G75	
HSK T.. V..	G74	
I		
ISO/DIS7388..	G101	
M		
MAS-BT.. BC..	G38	
MAS-BT.. ER..	G36	
MAS-BT.. HD..	G35	
MAS-BT.. HF..	G43	
MAS-BT.. KA..	G39	
MAS-BT.. KD..	G43	
MAS-BT.. MA..	G41	
MAS-BT.. MK..	G42	
MAS-BT.. MK..C..	G42	
MAS-BT.. QA..	G40	
MAS-BT.. SF..	G33, G34	
MAS-BT.. WE..	G27, G28, G29, G30, G31	
MAS-BT.. WN..	G32	
MAS-BT..D.. ER..D..	G37	
MAS-BT-30-A..	G100	
MAS-BT-30-B..	G100	
MAS-BT-45-A..	G100	
MAS-BT-45-B..	G100	
MAS-BT-90-A..	G100	
MAS-BT-90-B..	G100	
P		
PM 1	E14	
PM 2	E14	
PM 3	E14	
PMC.. 1.5D	E15, E17	
PMC.. 2.25	E16, E18	
PSC.. BH..	G80	
PSC.. ER..	G63	
PSC.. HD..	G62	
PSC.. HF..	G66, G82	
PSC.. KA..	G64	
PSC.. KD..	G66, G82	
PSC.. M..	G65	
PSC.. MK..	G65	
PSC.. R..	G81	
PSC.. SF..	G60, G61	
PSC.. SH2L00..	G78	
PSC.. SH2R00..	G78	
PSC.. SH3L00..	G79	
PSC.. SH3R00..	G79	
PSC.. SHL00..	G77	
PSC.. SHL45..	G77	
PSC.. SHN90..	G78	
PSC.. SHR00..	G77	
PSC.. SHR45..	G77	
PSC.. V..	G81	
PSC.. WE..	G58	
PSC.. WN..	G59	
S		
SM-BC..	G96	
SM-ER..	G95	
SM-ER.. D	G95	
SNHU	B18	
SNMG	A13	
T		
TNMG	A13	
U		
UT.. AD..	G67, G86	
UT.. BH..	G83	
UT.. ER..	G69	
UT.. ES.. OSN..	G83	
UT.. ES.. SSN..	G83	
UT.. HF..	G86	
UT.. QA..	G70	
UT.. SH..	G84	
UT.. V..	G85	
UT.. VLG..	G85	
UT.. WE..	G67	
UT.. WEWN..	G68	
UT63-32..	G84	
UT63-SH..	G84	
V		
VNMG	A14	
W		
W4420 ...	F14	
WNMG	A14	



-  Logistics
-  Headquarters
-  Production sites
-  Sales companies

-  Mamer
-  Reutte
-  Gabrovo
-  Empfingen
-  Hitzacker
-  Alserio
-  Kolkata
-  Livange
-  Niederkorn
-  Biel
-  Warren
-  Kempten

- Luxembourg
- Austria
- Bulgaria
- Germany
- Germany
- Italy
- India
- Luxembourg
- Luxembourg
- Switzerland
- United States
- Germany

- Reutte
 - São Paulo
 - Gabrovo
 - Velké Meziříčí
- Austria
 - Brazil
 - Bulgaria
 - Czech Republic + Slovakia
 - Germany
 - United Kingdom
 - Hungary
 - India
 - India
 - India
 - India
 - Italy
 - Japan
 - Luxembourg + Belgium + France
 - Querétaro
 - Rosendaal
 - Krakow
 - Madrid
 - Biel
 - Warren
- Mexico
 - Netherlands
 - Poland
 - Spain
 - + Portugal
 - Switzerland
 - United States
 - + Canada

Headquarters:

CERATIZIT S.A.
LU-8232 Mamer
T. +352 31 20 85-1
E. info@ceratizit.com

www.ceratizit.com

Austria

CERATIZIT Austria GmbH
AT-6600 Reutte
T. +43 5672 200-0
E. info.austria@ceratizit.com

Brazil

CERATIZIT América Latina Ltda.
BR-06453-002 Barueri, São Paulo
T. +55 11 4133 2300
E. info.americalatina@ceratizit.com

Bulgaria

CERATIZIT Bulgaria AG
BG-5301 Gabrovo
T. +359 66 812 206
E. info.bulgaria@ceratizit.com

China

CB-CERATIZIT Tianjin
CN-300384 Tianjin
T. +86 22 5810 7000

Czech Republic / Slovak Republic

CERATIZIT Office Czech Republic
CZ-594 01 Velké Meziříčí
T. +420 566 520 341
E. info.czechrepublic@ceratizit.com

France / Luxembourg / Belgium

CERATIZIT Luxembourg S.à r.l.
LU-8232 Mamer
T. +352 31 20 85-1
E. info@ceratizit.com

Germany

CERATIZIT Deutschland GmbH
DE-72186 Empfingen
T. +49 7485 99802 0
E. info.deutschland@ceratizit.com

Great Britain

CERATIZIT Office UK
UK-Sheffield S9 1XU
Toll Free 0800 048 4877 / 4878
T. +44 1925 261 161
E. info.uk@ceratizit.com

Hungary

CERATIZIT Office Hungary
HU-1138 Budapest
T. +36 1 437 0930
E. info.hungary@ceratizit.com

India

CERATIZIT India Pvt. Ltd.
IN-Bengaluru 560099
T. +91 80 4043 1262
E. ctindia.south@ceratizit.com

CERATIZIT India Pvt. Ltd.

IN-Chennai 600037
T. +91 44 4269 4350
E. ctindia.south@ceratizit.com

CERATIZIT India Pvt. Ltd.

IN-Coimbatore 641009
T. +91 4224 273 373
E. ctindia.south@ceratizit.com

CERATIZIT India Pvt. Ltd.

IN-Gurgaon 122002
T. +91 124 4018 481
E. ctindia.north@ceratizit.com

CERATIZIT India Pvt. Ltd.

IN-Pune 411018
T. +91 20 6529 0628
E. ctindia.west@ceratizit.com

Indonesia

CB-CERATIZIT Indonesia
ID-17530 Bekasi
T. +62-21-2961-2351

Italy

CERATIZIT Italia S.p.A.
IT-22040 Alserio (CO)
T. +39 031 6349 211
E. info.italia@ceratizit.com

Mexico

CERATIZIT México, S.A. de C.V.
MX-76040 Querétaro, QRO
T. +52 442 225 9173
E. info.mexico@ceratizit.com

Netherlands

CERATIZIT Nederland B.V.
NL-4707 AT Roosendaal
T. +31 165 55 08 00
E. info.nederland@ceratizit.com

Poland

CERATIZIT Office Poland
PL-30-443 Kraków
T. +48 12 252 8591
E. info.polska@ceratizit.com

Spain / Portugal

CERATIZIT Ibérica S.L.
ES-28031 Madrid
T. +34 91 351 0609
E. info.iberica@ceratizit.com

Taiwan

CB-CERATIZIT Tamsui
TW-25152-Tamsui
T. +886 2 2622 1668

USA / Canada

CERATIZIT USA, Inc.
US-Warren, MI 48089-1833
Toll free +1-800-783-2280
T. +1-586-759-2280
E. info.usa@ceratizit.com

We reserve the right to make technical changes for improvement of the product.

